

## Technical Information MAGLINK series 5300, 5400, and N(autic)-5400



INTRA-AUTOMATION GmbH  
Otto-Hahn-Strasse 20  
D- 41515 Grevenbroich  
Tel.: +49-(0) 21 81 / 75 66 5-0  
Fax: +49-(0) 21 81 / 6 44 92  
E-mail: [info@intra-automation.de](mailto:info@intra-automation.de)  
[www.intra-automation.de](http://www.intra-automation.de)

January 2005

All rights reserved

Please send all comments and questions about the MAGLINK-catalogue to:

[info@intra-automation.de](mailto:info@intra-automation.de)

## Copyright

### **Copyright 2003 by Intra-Automation GmbH**

No part of this catalogue may be reproduced in any way (print, photo copied or any other method) without prior written authorization by Intra-Automation GmbH nor may this catalogue be used, distributed or copied in any electronic format.

### **Scope and Validity**

This catalogue only covers the MAGLINK-level-gauging-systems. Information about other products manufactured by Intra-Automation, such as magnetic site level gauges, flow meters, ultra sound, flow computers, signal converters etc can be requested via our homepage [www.intra-automation.de](http://www.intra-automation.de), per e-mail ([info@intra-automation.de](mailto:info@intra-automation.de)) or per Fax (+49-(0) 21 81 / 6 44 92).

### **Categorizing of MAGLINK-level-measurement-system according to the Pressure Instrument Guidelines 97/23EG (PED)**

The MAGLINK-level-gauging-system is not a pressure instrument according to these guidelines.

### **Miscellaneous**

The information contained in catalogues, sales literature and other written submittals, e.g. drawings and submittals containing technical proposals are to be checked by the customer prior to acceptance and installation. A customer cannot derive any claims from such submittals and additional services against Intra-Automation GmbH or its employees, except in such cases where these have acted in bad faith or in a negligently way. Intra-Automation reserves the right to alter their products within reasonable and commonly acceptable limits – applicable also to already accepted orders – without notification. All trade marks used in this publication remain the property of the respective firm. MAGLINK is a trade mark of Intra-Automation GmbH.

## MAGLINK-LEVEL-GAUGING-SYSTEMS



<i>Copyright</i>	2
<b>Copyright 2003 by Intra-Automation GmbH</b>	2
Scope and Validity	2
Miscellaneous	2
<b>MAGLINK-LEVEL-GAUGING-SYSTEMS</b>	3
<b>Advantages of the Maglink-Level-Gauging-Systems</b>	5
<b>Measurement principle</b>	5
<b>Indicator Head and Scale</b>	6
<b>Guiding Tube</b>	7
<b>Float Systems</b>	8
• types of floats	8
• Immersion Depths	10
<b>Switches / Transmitters</b>	13
• Switches	13
• Transmitters	13
<b>Approvals</b>	14
<b>Accuracies</b>	14
<b>Weight</b>	14
<i>Order Codes</i>	15
<b>Order code Maglink series 5300 (without Ex-approval)</b>	15
<b>Order code Maglink series 5400 (Ex-approval)</b>	18
<b>Order code Maglink series Nautic-5400 (Ex-approval)</b>	21
<b>Specification sheet for MAGLINK</b>	24
<b>Mounting options/ dimensions</b>	25

## Advantages of the Maglink-Level-Gauging-Systems

- ◆ sealed system for pressure or vacuum services
- ◆ high accuracy (linear transmission)
- ◆ materials of construction for corrosive services
- ◆ no calibration required
- ◆ remote electronic indication and/or alarm switches
- ◆ readability at eye level
- ◆ good readability through direct reading scale  $\varnothing$  250 mm
- ◆ double-pointer-indication (Standard)
- ◆ mechanical operation (explosion proof available)
- ◆ insensitive to foam
- ◆ simple operation and maintenance
- ◆ interface measurements
- ◆ weatherproof housing
- ◆ direct mounting on top of the tank, optional **indication on the side of the tank**
- ◆ open and sealed tanks
- ◆ underground tanks
- ◆ freight-, storage- and service tanks on ships
- ◆ isolation between measured space and measurement system
- ◆ simple mechanic assembly

## Measurement principle

The level gauging system „MAGLINK“ includes three main parts::

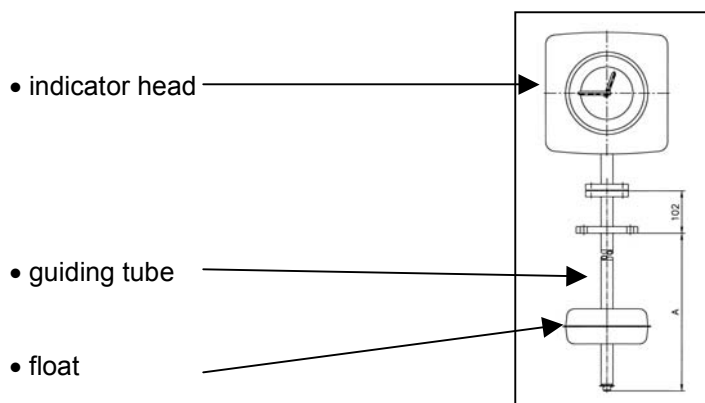

Fig. 01: Maglink

The indicator head is mounted directly on top of the guiding tube. The guiding tube is completely sealed towards the inside of the tank. A stainless steel wire is attached to a spring actuated drum located within the indicator head. The other end of the wire is fixated to a stainless steel plate that works as an end stop at high level. The plate is connected to a magnet (follower magnet) via a stainless steel wire (offset wire). This magnet is placed inside the guiding tube. The float contains an annular magnet. It actuates a magnetic coupling between the float and the follower magnet. A change in level causes a linear transmission to the indicator head through the wire as the float rises or sinks along the guiding tube. A high precision gearbox with clockwork motor compensates for the weight of the follower magnet and eliminates any backlash of the indication. A precision drum retains the wire. The standard indication head is equipped with two pointers. The read pointer indicates meters or feet and the black pointer centimeters or inches while the respective measuring ranges have the same color on the scale. For liquids with different densities and viscosities refer to page 8 where matching floats are described.

## Indicator Head and Scale

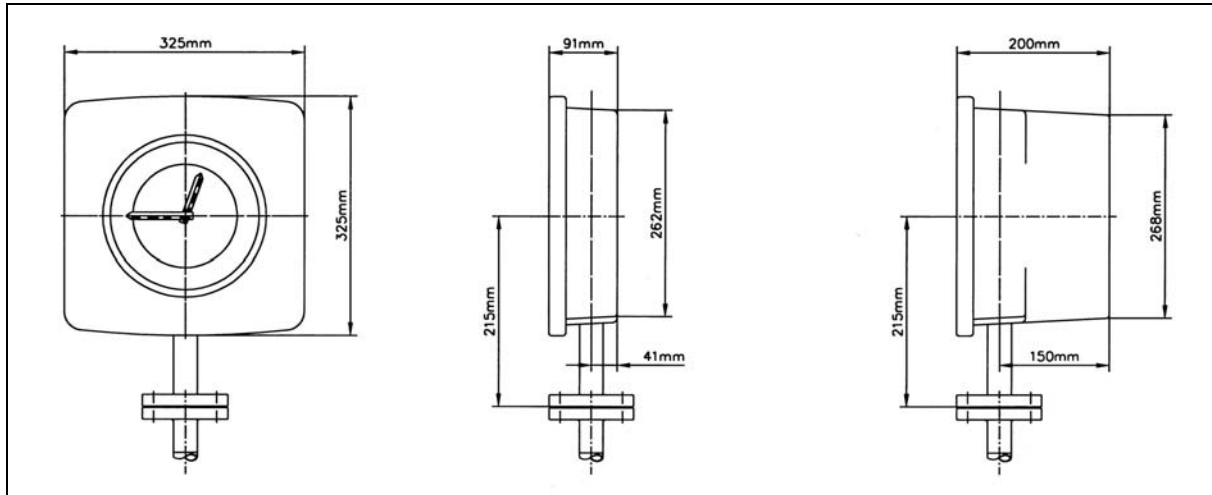

Fig. 02: Maglink-head

with flat housing

with wide housing

Basically there are three different housings:

- flat cast housing : used only for visual indication,
- wide cast housing : used for visual indication **and** optional level switches and/or integral transmitter for 4-20 mA output.

- nautical housing:

In this case the housing is equipped with an additional cover on its backside for a simpler mounting, installation and maintenance. design for open sea ships

Technical data **housing**:

- materials : housing – cast aluminum (standard), optional steel (nautical)  
viewing glass, Ø220mm – glass (standard), optional Macrolon
- painting : PUR- polyester powder lacquer  
layer thickness approx. 70 µm  
color black
- ambient temperature : -40 °C (-40 °F) though 66 °C (150 °F)
- protection class : IP 65 (NEMA4)

Technical data **scale**:

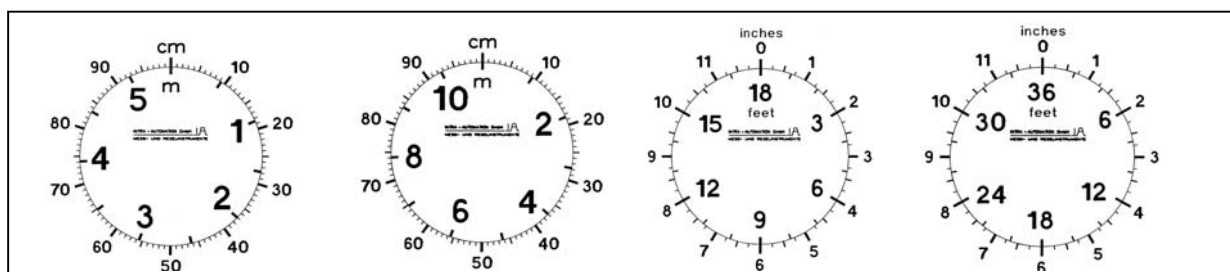

0-5,4m

0-10,8m

0-18 ft

0-36 ft

Fig. 03: standard scales

The scale of the Maglink-Level-Gauge-System has a diameter of Ø 220 mm. Two different kinds of scales can be chosen.

- Standard scale
  - design: double-pointer (*red / black*)
  - scaling: meters (*red*)/ centimeters (*black*) or feet (*red*)/ inches (*black*)
  - measuring range:: 0 - 5,4 m; 0 – 10,8 m; 0 – 18 ft or 0 – 36 ft
  - material: aluminum, white primed
  
- Special scale (optional)
  - design: one pointer (*black*)
  - scaling: according to customer specification (i.e. in cm; mm; ft; inch; Liter; m<sup>3</sup>)
  - measuring range: according to customer specification
  - material: aluminum, white primed

## Guiding Tube

The guiding tube consists of the following parts:

- weld on head mounting flange  
1" 150 lbs,
- tank mounting flange  
(standard DN50 PN16 or 2" 150 lbs RF)
- guiding tube
- end stop  
or bottom support for measurement length A > 3000mm.

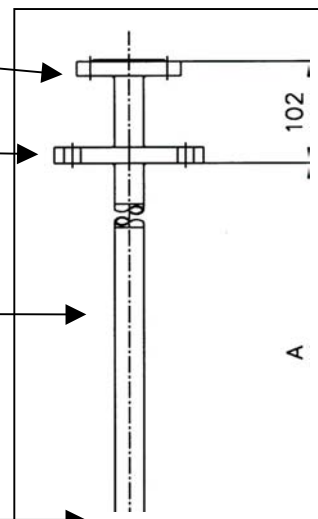

Fig. 04: guiding tube

Technical data:

- materials : 1.4571 = 316 Ti (standard), PP, PVC, PVDF  
(further materials upon request)
- max. length : 14000 mm (from 6000mm multipart)
- max. operating temperature : 0 °C (32 °F) through 250 °C (480 °F) → 1.4571;  
0 °C (32 °F) through 60 °C (140 °F) → PP, PVC, PVDF
- max. operating pressure : 118 bar (1734 psig) → 1.4571 = 316 Ti (standard),  
254 bar (3735 psig) → 1.4571 = 316 Ti (thick wall);  
6 bar ( 102 psig) → PP, PVC, PVDF

## Float Systems

- types of floats

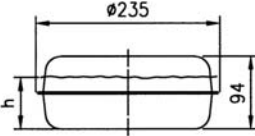
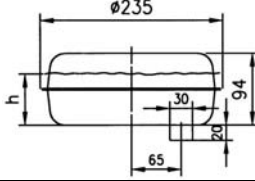
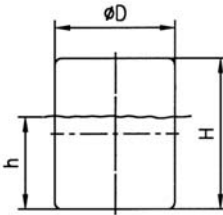
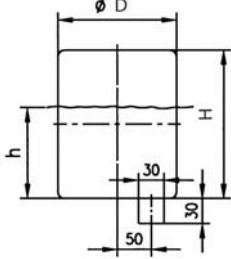
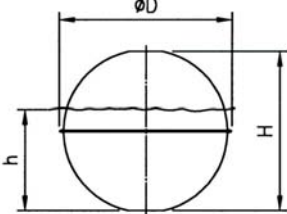
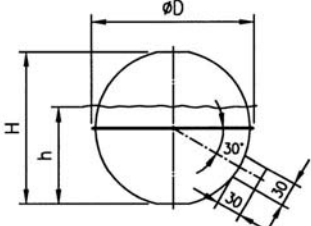
Float	Data (1, 2, 3)	Standard version	Ex-version
<b>Type A</b> (Standard)  (4)	min. 0,5 kg/dm <sup>3</sup> max. 3,5 bar (50 psig) max. 250 °C (480 °F) mat.: 1.4571 (316Ti)		
<b>Type B</b>  (4)	min. 0,7 kg/dm <sup>3</sup> max. 5 bar (150 psig) max. 250 °C (480 °F) <b>mat.: 1.4571 (316Ti)</b>  ØD = 140 mm H = 178 mm		
<b>Type C1</b>  (4)	min. 0,75 kg/dm <sup>3</sup> max. 25 bar (350 psig) max. 250 °C (480 °F) <b>mat.: 1.4571 (316Ti)</b>  ØD = 190 mm H = 184 mm	 	
<b>Type C2</b>  (4)	min. 0,58 kg/dm <sup>3</sup> max. 18 bar (250 psig) max. 250 °C (480 °F) <b>mat.: 1.4571 (316Ti)</b>  ØD = 229 mm H = 206 mm		
<b>Type C3</b>  (4)	min. 0,35 kg/dm <sup>3</sup> max. 8,5 bar (120 psig) max. 250 °C (480 °F) <b>mat.: 1.4571 (316Ti)</b>  ØD = 267 mm H = 254 mm		

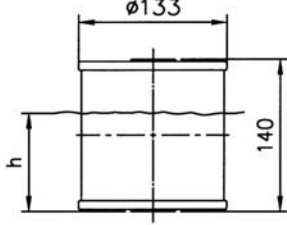
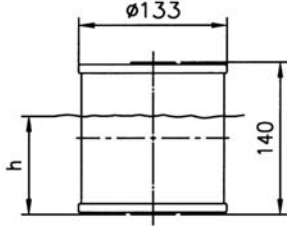
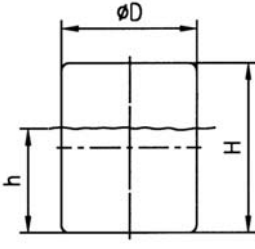
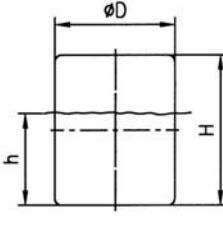
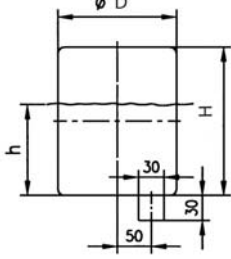
Float	Data (1, 2, 3)	Standard version	Ex-version
<b>Type F1</b> (4)	min. 0,65 kg/dm <sup>3</sup> max. 7 bar (100 psig) max. 60 °C (140 °F) mat.: <b>Polypropylene (PP)</b>		
<b>Type F2</b> (4)	min. 0,80kg/dm <sup>3</sup> max. 7 bar (100 psig) max. 60 °C (140 °F) mat.: <b>Polyvinylchloride (PVC)</b>		
<b>Type G</b> (5)	min. 0,60 kg/dm <sup>3</sup> max. 3,2 bar (45 psig) max. 250 °C (480 °F) mat.: <b>Glass</b>  ØD = 150 mm H = 175 mm		
<b>Type T</b> (4)	min. 0,52 kg/dm <sup>3</sup> max. 18 bar (250 psig) max. 250 °C (480 °F) mat.: <b>Titan</b>  ØD = 94 mm H = 240 mm		

- 1) Except the glass float all other float types can be vented for high pressure applications
- 2) It should be avoided to use floats close to their specified minimal liquid density
- 3) Special materials and –dimensions upon request
- 4) Version for interface measurements requires a minimal difference in density of **0,2 kg/dm<sup>3</sup>**
- 5) Version for interface measurements requires a minimal difference in density of **0,4 kg/dm<sup>3</sup>**

- Immersion Depths

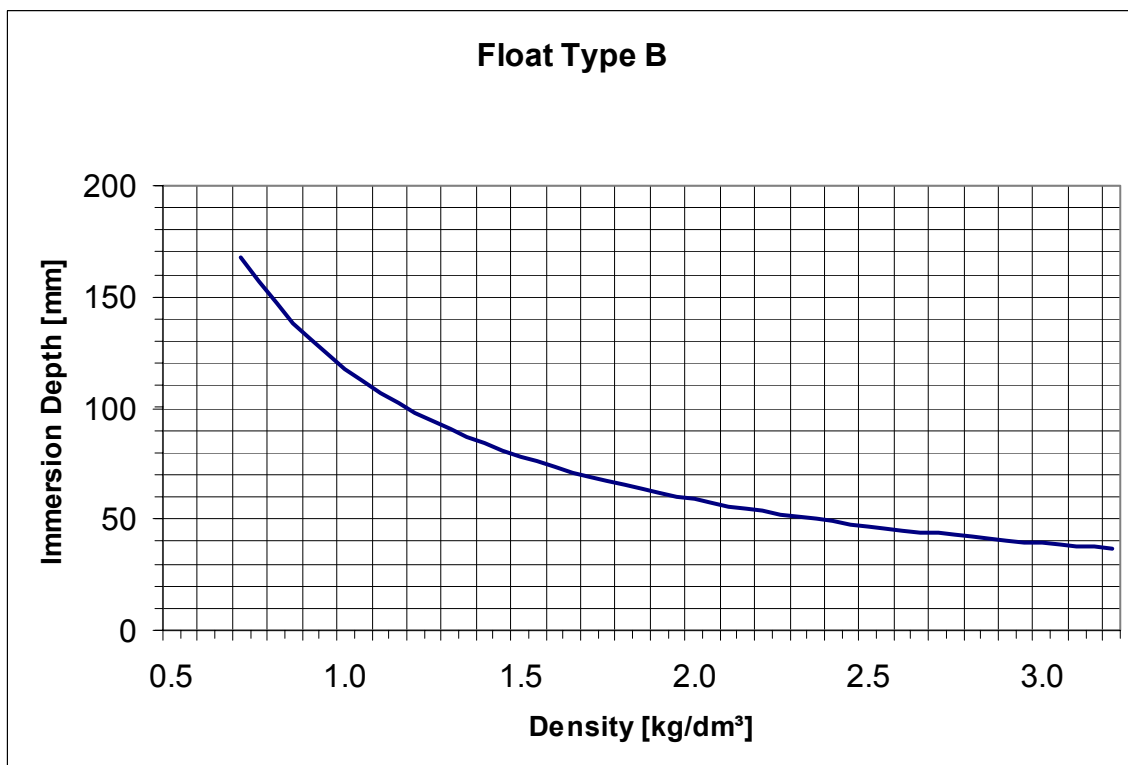
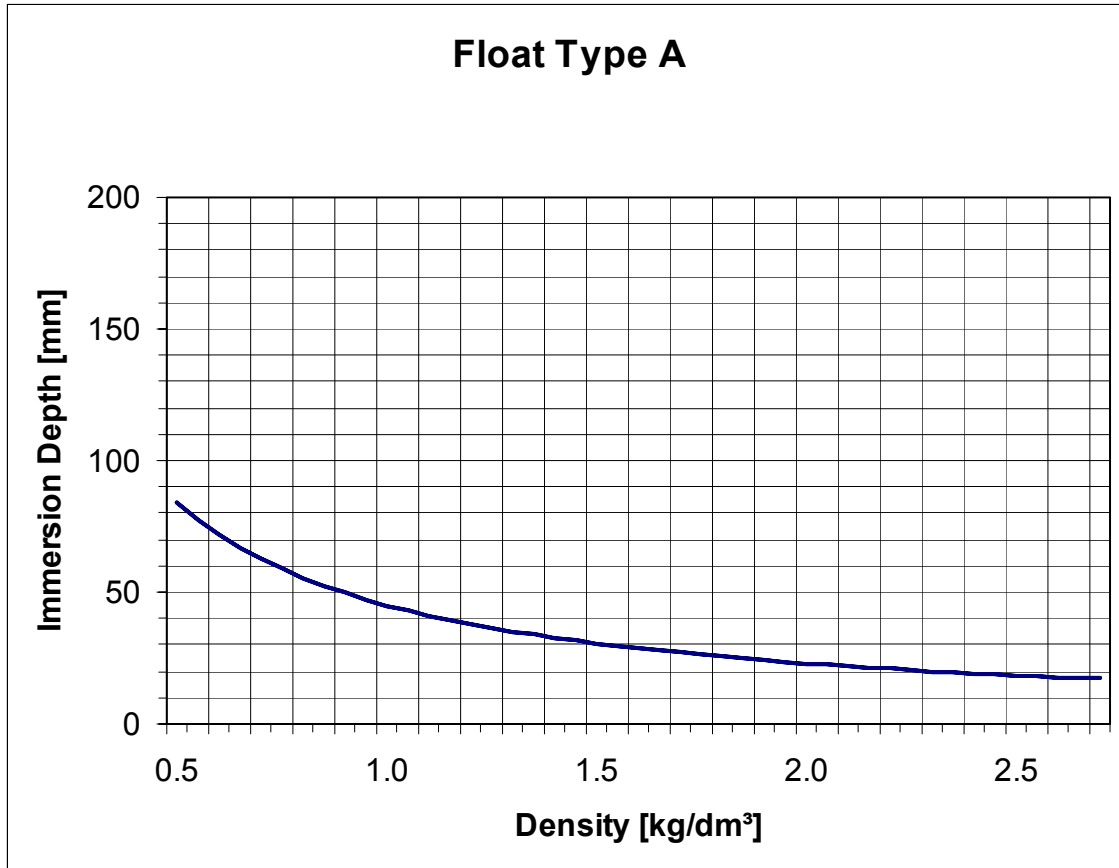

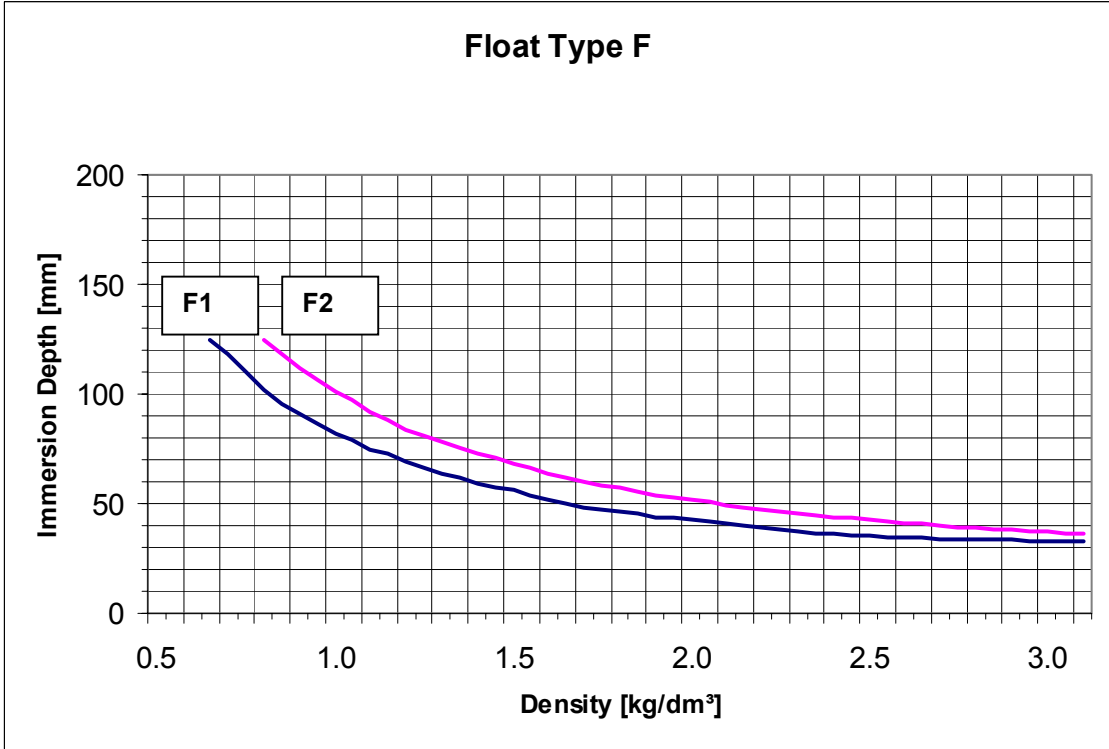
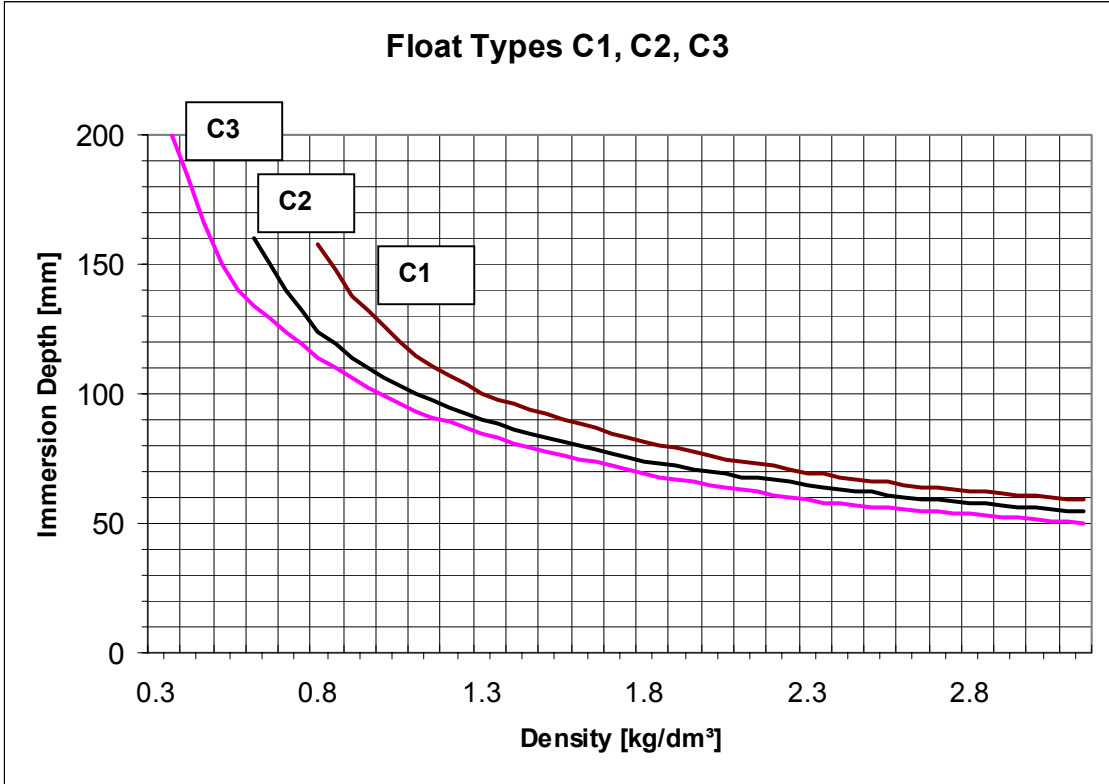

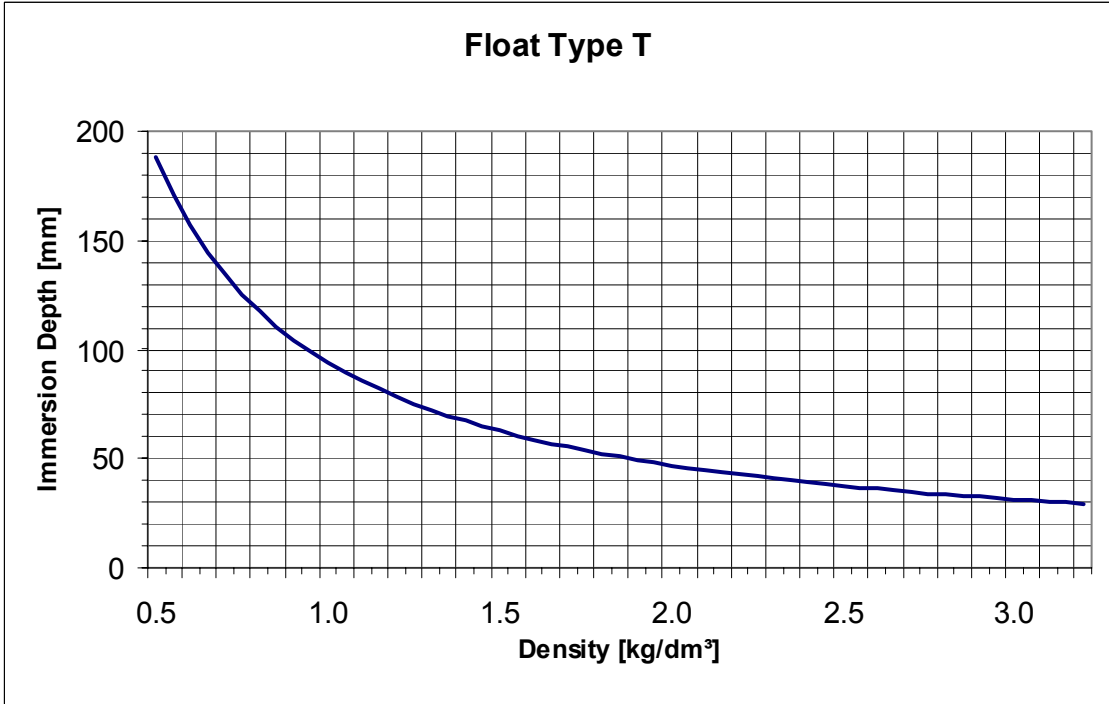
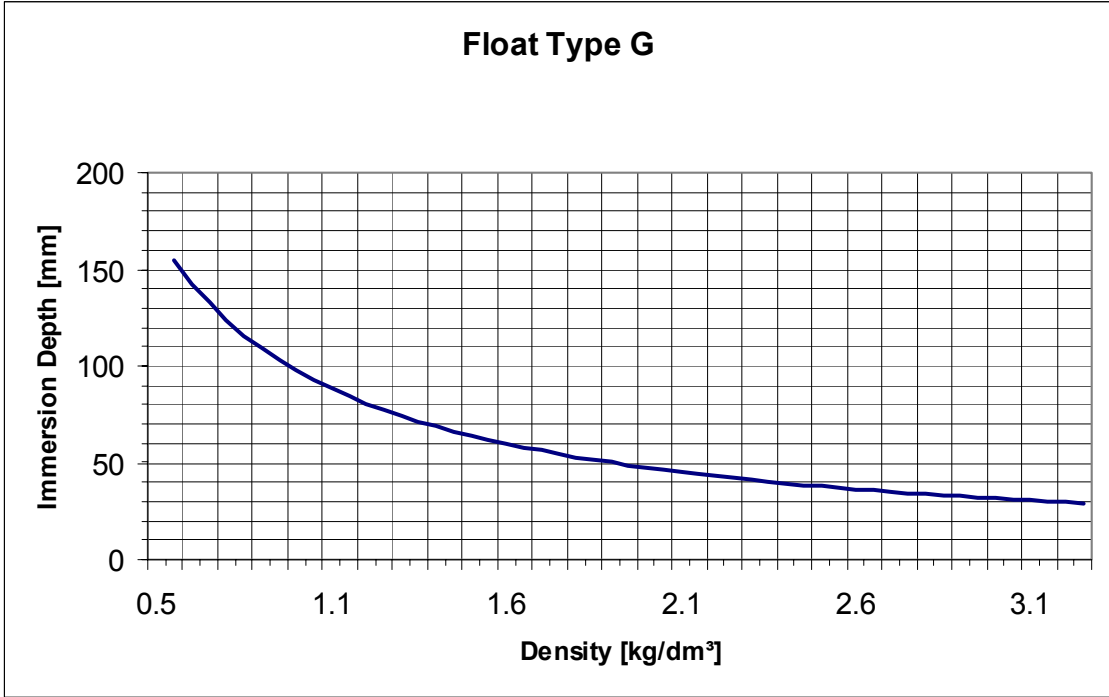

## Switches / Transmitters

- Switches**

Type	Description		
<b>B</b>	Slot proximity switch	Explosion protection Protection class Rated voltage Rated current Rated power Inductivity Capacity EMC	Ex II 2 G EEx ia IIC T6  IP 67 max. 16 VDC (intrinsically safe circuit) max. 25 mA max. 34 mW 30 nF 100 µH EN 50014:1997; EN 50020:1994
<b>C</b>	Micro switch  (change-over contact) (SPDT)	Explosion protection Protection class  Utilization category Rated voltage Rated current	Ex II 2 G EEx de IIC bzw. EEx d IIC  IP 66  AC-15 max. 250 V max. 4 A
			AC-15 max. 400 V max. 2 A
			DC-13 max. 250 V max. 0,15 A

- Transmitters**

Type	Description		
<b>E</b>	Position sensing transducer	Explosion protection  Approval Rated voltage Rated current Rated power Capacity External burden EMC  Accuracy Output signal	Ex II 2 G EEx ia IIC T6  German Lloyd max. 30 VDC max. 160 mA max. 1 W ≤ 10 nF (internal) R = (supply voltage-12V)/ Signal value I EN 50014:1997; EN 50020:1994  ≤ 1,5 % of rate 4..20 mA (2-, 3- or 4-wire-version) 0..10/20 mA (3- or 4- wire-version)

## Approvals

- Maglink Series **5300 (without explosion protection)**

Type	Approval
53__-GL-...	German Lloyd-approval

- Maglink Series **5400 (with explosion protection)**

Type	Approval
54__-GL-...	German Lloyd-approval
544_-D-...	⊕ II 1/2 G EEx ed IIC T4
544_-I-...	⊕ II 1/2 G EEx ia IIC T4
548_-I-...	
549_-I-...	
54__-...	⊕ II 1/2 G

## Accuracies

- Measurement accuracy :  $\pm (2 + L)$  mm  
with „L“ = length of the guiding tube in meters
- Response sensitivity to float movements :  $\pm 2$  mm
- Reproducibility :  $\pm 2$  mm

## Weight

- Model 531../ 541.. (only Indication = flat indicator head)**  
 appr. weight =  $15 + (2 \times L) + [\frac{1}{3} \times (F)^2]$  (metric units)  
 appr. weight =  $33,05 + (0.111 \times L) + [0.735 \times (F)^2]$  (anglo-american units)
- Model 53..../ 54.... (Indication+switches/transmitter = deep indicator head)**  
 appr. weight =  $17 + (2 \times L) + [\frac{1}{3} \times (F)^2]$  (metric units)  
 appr. weight =  $37,45 + (0.111 \times L) + [0.735 \times (F)^2]$  (anglo-american units)

Value	metric		Example
	Process flange $\leq DN65/ 2 \frac{1}{2}''$	Process flange $> DN65/ 2 \frac{1}{2}''$	
L	Length of guide tube in m	Length of guide tube in m	Model 531.. with flange DN100 Guide tube length = 3000 mm L = 3
F	0	Flange size in inch	F = 4 Weight = $15 + 2 \times 3 + [\frac{1}{3} \times (4)^2] = 26,3$ kg

Value	anglo-american		Example
	Process flange $\leq DN65/ 2 \frac{1}{2}''$	Process flange $> DN65/ 2 \frac{1}{2}''$	
L	Length of guide tube in inch	Length of guide tube in inch	Model 531.. with flange 4" Guide tube length = 118 inch L = 118
F	0	Flange size in inch	F = 4 Weight = $33,05 + 0,111 \times 118 + [0,735 \times (4)^2] = 57,9$ lbs

## Order Codes

### Order code Maglink series 5300 (without Ex-approval)

<b>1. Maglink type</b>	
<b>53</b>	without explosion protection
<b>2. Maglink head</b>	
<b>1</b>	only local indication
<b>4</b>	local indication, max. 4 electr. switches or max. 3 slot proximity switches possible
<b>8</b>	local indication, max. 1 electr. transmitter, max. 3 electr. switches or max. 3 slot proximity switches possible
<b>9</b>	local indication, max. 1 electr. transmitter possible
<b>3. scale</b>	
<b>1</b>	0.. 5,4m
<b>2</b>	0..10,8m
<b>3</b>	0..18 feet
<b>4</b>	0..36 feet
<b>5</b>	single pointer style (f.e.: mm, %, inches)
<b>Y3</b>	Other
	-
<b>4. classification</b>	
<b>GL</b>	Germanischer Lloyd; approval: 87 365-82 HH
<b>Y4</b>	other
<b>5. transmitter (depends on classification)</b>	
<b>0</b>	without
<b>E</b>	1 electr. transmitter; output signal: (0)4...20 mA power supply: 12...30 V; -20...70 °C; Genauigkeit: <= 1,5%
<b>Y5</b>	other
<b>6. switch (depends on classification)</b>	
<b>00</b>	without
<b>B1</b>	1 slot proximity switch type B
<b>B2</b>	2 slot proximity switches type B
<b>B3</b>	3 slot proximity switches type B
<b>B4</b>	4 slot proximity switches type B
<b>C1</b>	1 electr. switch type C
<b>C2</b>	2 electr. switches type C
<b>C3</b>	3 electr. switches type C
<b>C4</b>	4 electr. switches type C
<b>Y6</b>	other
<b>7. float</b>	
<b>A</b>	∅235x94mm; 1.4571; min. 0,5 kg/dm <sup>3</sup> ; max. 3,5 bar; max. 250 °C
<b>B</b>	∅140x178mm; 1.4571; min. 0,7 kg/dm <sup>3</sup> ; max. 5 bar; max. 250 °C
<b>C1</b>	∅190x184mm; 1.4571; min. 0,75 kg/dm <sup>3</sup> ; max. 25 bar; max. 250 °C
<b>C2</b>	∅229x206mm; 1.4571; min. 0,58 kg/dm <sup>3</sup> ; max. 18 bar; max. 250 °C
<b>C3</b>	∅267x254mm; 1.4571; min. 0,35 kg/dm <sup>3</sup> ; max. 8,5 bar; max. 250 °C
<b>F1</b>	∅133x140mm; PP; min. 0,65 kg/dm <sup>3</sup> ; max. 7 bar; max. 60 °C
<b>F2</b>	∅133x140mm; PVC; min. 0,8 kg/dm <sup>3</sup> ; max. 7 bar; max. 60 °C
<b>T</b>	∅94x240mm; 3.7035 (titanium); min. 0,52 kg/dm <sup>3</sup> ; max. 18 bar; max. 250 °C
<b>Y7</b>	other
<b>8. interface level measurement</b> <i>[min. difference in density: 0,2 kg/dm<sup>3</sup> (0,4 kg/dm<sup>3</sup> f. glass)]</i>	
<b>0</b>	without
<b>E</b>	interface level measurement
<b>Y8</b>	other
<b>9. coating (except float type G)</b>	
<b>0</b>	ohne Beschichtung
<b>H</b>	float coating halar (except float type G)
<b>P</b>	float coating PVDF (except float type G)
<b>Y9</b>	other

## Order code Maglink series 5300 (continued)

10. guide tube length			
<b>RM</b>	guide tube; Ø32x2mm; <i>L ≤ 3000mm</i>		length in mm
<b>RZ</b>	guide tube; 1" Sch40; <i>L &gt; 3000mm</i>		length in mm
<b>RZ5</b>	guide tube; 1" Sch40; <i>L ab 5500mm (mehnteilig)</i>		length in mm
11. guide tube material			
<b>S</b>	316Ti (Standard)		
<b>P</b>	PP		
<b>Q</b>	PVC		
<b>L</b>	PVDF		
<b>Y11</b>	other		
12. distance head/ tank mounting flange			
<b>B0</b>	standard, B=102mm		
<b>BG</b>	man hole mounting; min. base B=500mm;		add. length in mm
<b>Y12</b>	other		
13. tank mounting flange always identical to guide tube material			
<b>SM</b>	flanges acc. to DIN		
<b>SA</b>	flanges acc. to ANSI		
<b>Y13</b>	other		
14. sealing surface			
<b>1</b>	DIN		
<b>2</b>	ANSI RF		
<b>3</b>	ANSI RF SF (smooth finish)		
<b>5</b>	ANSI FF		
<b>Y14</b>	other		
15. PN, material and DN of the guide tube flange for tank mounting			
<b>CC1</b>	PN16 / 150 lbs	CS	DN50 / 2"
<b>CC2</b>	PN40 / 300 lbs	CS	DN50 / 2"
<b>C01</b>	PN16 / 150 lbs	316Ti	DN50 / 2"
<b>C02</b>	PN40 / 300 lbs	316Ti	DN50 / 2"
<b>C80</b>	PN16 / 150 lbs	PP	DN50 / 2"
<b>C90</b>	PN16 / 150 lbs	PVC	DN50 / 2"
<b>CX1</b>	PN16 / 150 lbs	316Ti/PVDF	DN50 / 2"
<b>CX2</b>	PN40 / 300 lbs	316Ti/PVDF	DN50 / 2"
<b>EC1</b>	PN16 / 150 lbs	CS	DN80 / 3"
<b>EC2</b>	PN40 / 300 lbs	CS	DN80 / 3"
<b>E01</b>	PN16 / 150 lbs	316Ti	DN80 / 3"
<b>E02</b>	PN40 / 300 lbs	316Ti	DN80 / 3"
<b>E80</b>	PN16 / 150 lbs	PP	DN80 / 3"
<b>E90</b>	PN16 / 150 lbs	PVC	DN80 / 3"
<b>EX1</b>	PN16 / 150 lbs	316Ti/PVDF	DN80 / 3"
<b>EX2</b>	PN40 / 300 lbs	316Ti/PVDF	DN80 / 3"
<b>FC1</b>	PN16 / 150 lbs	CS	DN100 / 4"
<b>FC2</b>	PN40 / 300 lbs	CS	DN100 / 4"
<b>F01</b>	PN16 / 150 lbs	316Ti	DN100 / 4"
<b>F02</b>	PN40 / 300 lbs	316Ti	DN100 / 4"
<b>F80</b>	PN16 / 150 lbs	PP	DN100 / 4"
<b>F90</b>	PN16 / 150 lbs	PVC	DN100 / 4"
<b>FX1</b>	PN16 / 150 lbs	316Ti/PVDF	DN100 / 4"
<b>FX2</b>	PN40 / 300 lbs	316Ti/PVDF	DN100 / 4"

## Order code Maglink series 5300 (continued)

<b>GC1</b>	PN16 / 150 lbs	CS	DN150 / 6"
<b>GC2</b>	PN40 / 300 lbs	CS	DN150 / 6"
<b>G01</b>	PN16 / 150 lbs	316Ti	DN150 / 6"
<b>G02</b>	PN40 / 300 lbs	316Ti	DN150 / 6"
<b>G80</b>	PN16 / 150 lbs	PP	DN150 / 6"
<b>G90</b>	PN16 / 150 lbs	PVC	DN150 / 6"
<b>GX1</b>	PN16 / 150 lbs	316Ti/PVDF	DN150 / 6"
<b>GX2</b>	PN40 / 300 lbs	316Ti/PVDF	DN150 / 6"
<b>HC1</b>	PN16 / 150 lbs	CS	DN200 / 8"
<b>HC2</b>	PN40 / 300 lbs	CS	DN200 / 8"
<b>H01</b>	PN16 / 150 lbs	316Ti	DN200 / 8"
<b>H02</b>	PN40 / 300 lbs	316Ti	DN200 / 8"
<b>H80</b>	PN16 / 150 lbs	PP	DN200 / 8"
<b>H90</b>	PN16 / 150 lbs	PVC	DN200 / 8"
<b>HX1</b>	PN16 / 150 lbs	316Ti/PVDF	DN200 / 8"
<b>HX2</b>	PN40 / 300 lbs	316Ti/PVDF	DN200 / 8"
<b>JC1</b>	PN16 / 150 lbs	CS	DN250 / 10"
<b>JC2</b>	PN40 / 300 lbs	CS	DN250 / 10"
<b>J01</b>	PN16 / 150 lbs	316Ti	DN250 / 10"
<b>J02</b>	PN40 / 300 lbs	316Ti	DN250 / 10"
<b>J80</b>	PN16 / 150 lbs	PP	DN250 / 10"
<b>J90</b>	PN16 / 150 lbs	PVC	DN250 / 10"
<b>JX1</b>	PN16 / 150 lbs	316Ti/PVDF	DN250 / 10"
<b>JX2</b>	PN40 / 300 lbs	316Ti/PVDF	DN250 / 10"
<b>Y15</b>	other		
<b>16. bottom support for guide tube length &gt;3000mm</b>			
<b>0</b>	without		
<b>C</b>	bottom support; material: CS/PTFE		
<b>S</b>	bottom support; material: 316Ti/PTFE		
<b>Y16</b>	other		
<b>17. indication on side of tank (tube mat.: CS, painted; elbow mat.: alu, painted)</b>			
<b>0</b>	without		
<b>SA</b>	with side tank indication		
<b>18. distance tank edge (G)/ upper tank edge To eye height (H) (dim. in mm)</b>			
<b>G/H</b>	G in mm / H in mm		

## Order code Maglink series 5400 (Ex-approval)

<b>1. Maglink type</b>	
<b>54</b>	With explosion protection; guide tube/ float suitable for use in zone 0 in acc. PTB 04 ATEX 1102
<b>2. Maglink head</b>	
<b>1</b>	only local indication
<b>4</b>	local indication, max. 4 electr. switches or max. 3 slot proximity switches possible
<b>8</b>	local indication, max. 1 electr. transmitter, max. 3 electr. switches or max. 3 slot proximity switches possible
<b>9</b>	local indication, max. 1 electr. transmitter possible
<b>3. scale</b>	
<b>1</b>	0.. 5,4m
<b>2</b>	0..10,8m
<b>3</b>	0..18 feet
<b>4</b>	0..36 feet
<b>5</b>	single pointer style (f.e.: mm, %, inches)
<b>Y3</b>	Other
-	
<b>4. classification</b>	
<b>D</b>	Ex II 1/2 G EEx ed IIC T4; PTB 04 ATEX 1102; - only in conjunction with type 544.. – <i>suitable for class I, div. 1, group A, T4 "flame proofed"</i>
<b>I</b>	Ex II 1/2 G EEx ia IIC T4; PTB 04 ATEX 1102; - only in conjunction with type 544../ 548/ 549.. – <i>suitable for class I, div. 1, group A, T4 "intrinsically safe"</i>
<b>GL</b>	Germanischer Lloyd; approval: 87 365-82 HH
<b>Y4</b>	other
<b>5. transmitter (depends on classification)</b>	
<b>0</b>	without
<b>E</b>	1 electr. transmitter; output signal: (0)4...20 mA; [Ex II 2 G EEx ia IIC T6]; power supply: 12...30 V; -20...70 °C; Genauigkeit: <= 1,5%
<b>Y5</b>	other
<b>6. switch (depends on classification)</b>	
<b>00</b>	without
<b>B1</b>	1 slot proximity switch type B; [Ex II 2 G EEx ia IIC T6]
<b>B2</b>	2 slot proximity switches type B; [Ex II 2 G EEx ia IIC T6]
<b>B3</b>	3 slot proximity switches type B; [Ex II 2 G EEx ia IIC T6]
<b>B4</b>	4 slot proximity switches type B; [Ex II 2 G EEx ia IIC T6]
<b>C1</b>	1 electr. switch type C; [II 2 G EEx de II C resp. EExd II C]
<b>C2</b>	2 electr. switches type C; [II 2 G EEx de II C resp. EExd II C]
<b>C3</b>	3 electr. switches type C; [II 2 G EEx de II C resp. EExd II C]
<b>C4</b>	4 electr. switches type C; [II 2 G EEx de II C resp. EExd II C]
<b>Y6</b>	other
<b>7. float</b>	
<b>A</b>	Ø235x94mm; 1.4571; min. 0,5 kg/dm <sup>3</sup> ; max. 3,5 bar; max. 250 °C
<b>B</b>	Ø140x178mm; 1.4571; min. 0,7 kg/dm <sup>3</sup> ; max. 5 bar; max. 250 °C
<b>C1</b>	Ø190x184mm; 1.4571; min. 0,75 kg/dm <sup>3</sup> ; max. 25 bar; max. 250 °C
<b>C2</b>	Ø229x206mm; 1.4571; min. 0,58 kg/dm <sup>3</sup> ; max. 18 bar; max. 250 °C
<b>C3</b>	Ø267x254mm; 1.4571; min. 0,35 kg/dm <sup>3</sup> ; max. 8,5 bar; max. 250 °C
<b>F1</b>	Ø133x140mm; PP; min. 0,65 kg/dm <sup>3</sup> ; max. 7 bar; max. 60 °C
<b>F2</b>	Ø133x140mm; PVC; min. 0,8 kg/dm <sup>3</sup> ; max. 7 bar; max. 60 °C
<b>T</b>	Ø94x240mm; 3.7035 (titanium); min. 0,52 kg/dm <sup>3</sup> ; max. 18 bar; max. 250 °C
<b>Y7</b>	other
<b>8. interface level measurement</b> <i>[min. difference in density: 0,2 kg/dm<sup>3</sup> (0,4 kg/dm<sup>3</sup> f. glass)]</i>	
<b>0</b>	without
<b>E</b>	Interface level measurement
<b>Y8</b>	other
<b>9. coating (except float type G)</b>	
<b>0</b>	ohne Beschichtung
<b>H</b>	float coating halar (except float type G)
<b>P</b>	float coating PVDF (except float type G)
<b>Y9</b>	other

## Order code Maglink series 5400 (continued)

10. guide tube length			
<b>RM</b>	guide tube; Ø32x2mm; <i>L ≤ 3000mm</i>		length in mm
<b>RZ</b>	guide tube; 1" Sch40; <i>L &gt; 3000mm</i>		length in mm
<b>RZ5</b>	guide tube; 1" Sch40; <i>L ab 5500mm (mehrteilig)</i>		length in mm
11. guide tube material			
<b>S</b>	316Ti (Standard)		
<b>P</b>	PP		
<b>Q</b>	PVC		
<b>L</b>	PVDF		
<b>Y11</b>	other		
12. distance head/ tank mounting flange			
<b>B0</b>	standard, B=102mm		
<b>BG</b>	man hole mounting; min. base B=500mm;		add. length in mm
<b>Y12</b>	other		
13. tank mounting flange			
<b>always identical to guide tube material</b>			
<b>SM</b>	flanges acc. to DIN		
<b>SA</b>	flanges acc. to ANSI		
<b>Y13</b>	other		
14. sealing surface			
<b>1</b>	DIN		
<b>2</b>	ANSI RF		
<b>3</b>	ANSI RF SF (smooth finish)		
<b>5</b>	ANSI FF		
<b>Y14</b>	other		
15. PN, material and DN of the guide tube flange for tank mounting			
<b>CC1</b>	PN16 / 150 lbs	CS	DN50 / 2"
<b>CC2</b>	PN40 / 300 lbs	CS	DN50 / 2"
<b>C01</b>	PN16 / 150 lbs	316Ti	DN50 / 2"
<b>C02</b>	PN40 / 300 lbs	316Ti	DN50 / 2"
<b>C80</b>	PN16 / 150 lbs	PP	DN50 / 2"
<b>C90</b>	PN16 / 150 lbs	PVC	DN50 / 2"
<b>CX1</b>	PN16 / 150 lbs	316Ti/PVDF	DN50 / 2"
<b>CX2</b>	PN40 / 300 lbs	316Ti/PVDF	DN50 / 2"
<b>EC1</b>	PN16 / 150 lbs	CS	DN80 / 3"
<b>EC2</b>	PN40 / 300 lbs	CS	DN80 / 3"
<b>E01</b>	PN16 / 150 lbs	316Ti	DN80 / 3"
<b>E02</b>	PN40 / 300 lbs	316Ti	DN80 / 3"
<b>E80</b>	PN16 / 150 lbs	PP	DN80 / 3"
<b>E90</b>	PN16 / 150 lbs	PVC	DN80 / 3"
<b>EX1</b>	PN16 / 150 lbs	316Ti/PVDF	DN80 / 3"
<b>EX2</b>	PN40 / 300 lbs	316Ti/PVDF	DN80 / 3"
<b>FC1</b>	PN16 / 150 lbs	CS	DN100 / 4"
<b>FC2</b>	PN40 / 300 lbs	CS	DN100 / 4"
<b>F01</b>	PN16 / 150 lbs	316Ti	DN100 / 4"
<b>F02</b>	PN40 / 300 lbs	316Ti	DN100 / 4"
<b>F80</b>	PN16 / 150 lbs	PP	DN100 / 4"
<b>F90</b>	PN16 / 150 lbs	PVC	DN100 / 4"
<b>FX1</b>	PN16 / 150 lbs	316Ti/PVDF	DN100 / 4"
<b>FX2</b>	PN40 / 300 lbs	316Ti/PVDF	DN100 / 4"

Order code Maglink series 5400 (continued)

<b>GC1</b>	PN16 / 150 lbs	CS	DN150 / 6"
<b>GC2</b>	PN40 / 300 lbs	CS	DN150 / 6"
<b>G01</b>	PN16 / 150 lbs	316Ti	DN150 / 6"
<b>G02</b>	PN40 / 300 lbs	316Ti	DN150 / 6"
<b>G80</b>	PN16 / 150 lbs	PP	DN150 / 6"
<b>G90</b>	PN16 / 150 lbs	PVC	DN150 / 6"
<b>GX1</b>	PN16 / 150 lbs	316Ti/PVDF	DN150 / 6"
<b>GX2</b>	PN40 / 300 lbs	316Ti/PVDF	DN150 / 6"
<b>HC1</b>	PN16 / 150 lbs	CS	DN200 / 8"
<b>HC2</b>	PN40 / 300 lbs	CS	DN200 / 8"
<b>H01</b>	PN16 / 150 lbs	316Ti	DN200 / 8"
<b>H02</b>	PN40 / 300 lbs	316Ti	DN200 / 8"
<b>H80</b>	PN16 / 150 lbs	PP	DN200 / 8"
<b>H90</b>	PN16 / 150 lbs	PVC	DN200 / 8"
<b>HX1</b>	PN16 / 150 lbs	316Ti/PVDF	DN200 / 8"
<b>HX2</b>	PN40 / 300 lbs	316Ti/PVDF	DN200 / 8"
<b>JC1</b>	PN16 / 150 lbs	CS	DN250 / 10"
<b>JC2</b>	PN40 / 300 lbs	CS	DN250 / 10"
<b>J01</b>	PN16 / 150 lbs	316Ti	DN250 / 10"
<b>J02</b>	PN40 / 300 lbs	316Ti	DN250 / 10"
<b>J80</b>	PN16 / 150 lbs	PP	DN250 / 10"
<b>J90</b>	PN16 / 150 lbs	PVC	DN250 / 10"
<b>JX1</b>	PN16 / 150 lbs	316Ti/PVDF	DN250 / 10"
<b>JX2</b>	PN40 / 300 lbs	316Ti/PVDF	DN250 / 10"
<b>Y15</b>	other		
<b>16. bottom support for guide tube length &gt;3000mm</b>			
<b>0</b>	without		
<b>C</b>	bottom support; material: CS/PTFE		
<b>S</b>	bottom support; material: 316Ti/PTFE		
<b>Y16</b>	other		
<b>17. indication on side of tank (tube mat.: CS, painted; elbow mat.: alu, painted)</b>			
<b>0</b>	without		
<b>SA</b>	with side tank indication		
<b>18. distance tank edge (G)/ upper tank edge To eye height (H) (dim. in mm)</b>			
<b>G/H</b>	G in mm / H in mm		

## Order code Maglink series Nautic-5400 (Ex-approval)

<b>1. Maglink type</b>	
<b>N-54</b>	Nautic with explosion protection; guide tube/ float suitable for use in zone 0 in acc. PTB 04 ATEX 1102
<b>2. Maglink head</b>	
<b>1</b>	only local indication
<b>4</b>	local indication, max. 4 electr. switches or max. 3 slot proximity switches possible
<b>3. scale</b>	
<b>2</b>	0..10,8m
<b>4</b>	0..36 feet
<b>5</b>	single pointer style (f.e.: mm, %, inches)
<b>Y3</b>	Other
-	
<b>4. classification</b>	
<b>D</b>	Ex II 1/2 G EEx ed IIC T4; PTB 04 ATEX 1102; - only in conjunction with type 544.. – suitable for class I, div. 1, group A, T4 "flame proofed"
<b>I</b>	Ex II 1/2 G EEx ia IIC T4; PTB 04 ATEX 1102; - only in conjunction with type 544../ 548/ 549.. – suitable for class I, div. 1, group A, T4 "intrinsically safe"
<b>GL</b>	Germanischer Lloyd; approval: 87 365-82 HH
<b>Y4</b>	other
<b>5. transmitter (depends on classification)</b>	
<b>0</b>	without
<b>6. switch (depends on classification)</b>	
<b>00</b>	without
<b>B1</b>	1 slot proximity switch type B; [Ex II 2 G EEx ia IIC T6]
<b>B2</b>	2 slot proximity switch type B; [Ex II 2 G EEx ia IIC T6]
<b>C1</b>	1 electr. switch type C; [II 2 G EEx de II C resp. EExd II C]
<b>C2</b>	2 electr. switch type C; [II 2 G EEx de II C resp. EExd II C]
<b>Y6</b>	other
<b>7. float</b>	
<b>A</b>	Ø235x94mm; 1.4571; min. 0,5 kg/dm <sup>3</sup> ; max. 3,5 bar; max. 250 °C
<b>B</b>	Ø140x178mm; 1.4571; min. 0,7 kg/dm <sup>3</sup> ; max. 5 bar; max. 250 °C
<b>C1</b>	Ø190x184mm; 1.4571; min. 0,75 kg/dm <sup>3</sup> ; max. 25 bar; max. 250 °C
<b>C2</b>	Ø229x206mm; 1.4571; min. 0,58 kg/dm <sup>3</sup> ; max. 18 bar; max. 250 °C
<b>C3</b>	Ø267x254mm; 1.4571; min. 0,35 kg/dm <sup>3</sup> ; max. 8,5 bar; max. 250 °C
<b>F1</b>	Ø133x140mm; PP; min. 0,65 kg/dm <sup>3</sup> ; max. 7 bar; max. 60 °C
<b>F2</b>	Ø133x140mm; PVC; min. 0,8 kg/dm <sup>3</sup> ; max. 7 bar; max. 60 °C
<b>T</b>	Ø94x240mm; 3.7035 (titanium); min. 0,52 kg/dm <sup>3</sup> ; max. 18 bar; max. 250 °C
<b>Y7</b>	other
<b>8. interface level measurement</b>	
<i>[min. difference in density: 0,2 kg/dm<sup>3</sup> (0,4 kg/dm<sup>3</sup> f. glass)]</i>	
<b>0</b>	without
<b>E</b>	Interface level measurement
<b>Y8</b>	other
<b>9. coating (except float type G)</b>	
<b>0</b>	ohne Beschichtung
<b>H</b>	float coating halar (except float type G)
<b>P</b>	float coating PVDF (except float type G)
<b>Y9</b>	other

## Order code Maglink series Nautic-5400 (continued)

10. guide tube length			
<b>RZ</b>	guide tube; 1" Sch40; <b>L &gt; 3000mm</b>		length in mm
<b>RZ5</b>	guide tube; 1" Sch40; <b>L ab 5500mm (meherteilig)</b>		length in mm
11. guide tube material			
<b>S</b>	316Ti (Standard)		
<b>P</b>	PP		
<b>Q</b>	PVC		
<b>L</b>	PVDF		
<b>Y11</b>	other		
12. distance head/ tank mounting flange			
<b>B0</b>	standard, B=102mm		
<b>BG</b>	man hole mounting; min. base B=500mm;		add. length in mm
<b>Y12</b>	other		
13. tank mounting flange always identical to guide tube material			
<b>SM</b>	flanges acc. to DIN		
<b>SA</b>	flanges acc. to ANSI		
<b>Y13</b>	other		
14. sealing surface			
<b>1</b>	DIN		
<b>2</b>	ANSI RF		
<b>3</b>	ANSI RF SF (smooth finish)		
<b>5</b>	ANSI FF		
<b>Y14</b>	other		
15. PN, material and DN of the guide tube flange for tank mounting			
<b>CC1</b>	PN16 / 150 lbs	CS	DN50 / 2"
<b>CC2</b>	PN40 / 300 lbs	CS	DN50 / 2"
<b>C01</b>	PN16 / 150 lbs	316Ti	DN50 / 2"
<b>C02</b>	PN40 / 300 lbs	316Ti	DN50 / 2"
<b>C80</b>	PN16 / 150 lbs	PP	DN50 / 2"
<b>C90</b>	PN16 / 150 lbs	PVC	DN50 / 2"
<b>CX1</b>	PN16 / 150 lbs	316Ti/PVDF	DN50 / 2"
<b>CX2</b>	PN40 / 300 lbs	316Ti/PVDF	DN50 / 2"
<b>EC1</b>	PN16 / 150 lbs	CS	DN80 / 3"
<b>EC2</b>	PN40 / 300 lbs	CS	DN80 / 3"
<b>E01</b>	PN16 / 150 lbs	316Ti	DN80 / 3"
<b>E02</b>	PN40 / 300 lbs	316Ti	DN80 / 3"
<b>E80</b>	PN16 / 150 lbs	PP	DN80 / 3"
<b>E90</b>	PN16 / 150 lbs	PVC	DN80 / 3"
<b>EX1</b>	PN16 / 150 lbs	316Ti/PVDF	DN80 / 3"
<b>EX2</b>	PN40 / 300 lbs	316Ti/PVDF	DN80 / 3"
<b>FC1</b>	PN16 / 150 lbs	CS	DN100 / 4"
<b>FC2</b>	PN40 / 300 lbs	CS	DN100 / 4"
<b>F01</b>	PN16 / 150 lbs	316Ti	DN100 / 4"
<b>F02</b>	PN40 / 300 lbs	316Ti	DN100 / 4"
<b>F80</b>	PN16 / 150 lbs	PP	DN100 / 4"
<b>F90</b>	PN16 / 150 lbs	PVC	DN100 / 4"
<b>FX1</b>	PN16 / 150 lbs	316Ti/PVDF	DN100 / 4"
<b>FX2</b>	PN40 / 300 lbs	316Ti/PVDF	DN100 / 4"

Order code Maglink series Nautic-5400 (continued)

<b>GC1</b>	PN16 / 150 lbs	CS	DN150 / 6"
<b>GC2</b>	PN40 / 300 lbs	CS	DN150 / 6"
<b>G01</b>	PN16 / 150 lbs	316Ti	DN150 / 6"
<b>G02</b>	PN40 / 300 lbs	316Ti	DN150 / 6"
<b>G80</b>	PN16 / 150 lbs	PP	DN150 / 6"
<b>G90</b>	PN16 / 150 lbs	PVC	DN150 / 6"
<b>GX1</b>	PN16 / 150 lbs	316Ti/PVDF	DN150 / 6"
<b>GX2</b>	PN40 / 300 lbs	316Ti/PVDF	DN150 / 6"
<b>HC1</b>	PN16 / 150 lbs	CS	DN200 / 8"
<b>HC2</b>	PN40 / 300 lbs	CS	DN200 / 8"
<b>H01</b>	PN16 / 150 lbs	316Ti	DN200 / 8"
<b>H02</b>	PN40 / 300 lbs	316Ti	DN200 / 8"
<b>H80</b>	PN16 / 150 lbs	PP	DN200 / 8"
<b>H90</b>	PN16 / 150 lbs	PVC	DN200 / 8"
<b>HX1</b>	PN16 / 150 lbs	316Ti/PVDF	DN200 / 8"
<b>HX2</b>	PN40 / 300 lbs	316Ti/PVDF	DN200 / 8"
<b>JC1</b>	PN16 / 150 lbs	CS	DN250 / 10"
<b>JC2</b>	PN40 / 300 lbs	CS	DN250 / 10"
<b>J01</b>	PN16 / 150 lbs	316Ti	DN250 / 10"
<b>J02</b>	PN40 / 300 lbs	316Ti	DN250 / 10"
<b>J80</b>	PN16 / 150 lbs	PP	DN250 / 10"
<b>J90</b>	PN16 / 150 lbs	PVC	DN250 / 10"
<b>JX1</b>	PN16 / 150 lbs	316Ti/PVDF	DN250 / 10"
<b>JX2</b>	PN40 / 300 lbs	316Ti/PVDF	DN250 / 10"
<b>Y15</b>	other		
<b>16. bottom support for guide tube length &gt;3000mm</b>			
<b>0</b>	without		
<b>C</b>	bottom support; material: CS/PTFE		
<b>S</b>	bottom support; material: 316Ti/PTFE		
<b>Y16</b>	other		

**Specification sheet for MAGLINK****General Information**

Customer

Ref.-no.

:

TAG-no.:

**Tank data**

Tank height (inside) :

Tank form

:

Tank connection

:

DIN-flange

ANSI-flange

Nominal diameter

Nominal pressure

:

Material

:

**Medium data**

Fluid

:

Concentration

:

Temperature

:

Pressure

**Desired version**

standard

EEx i

EEx d

GL

indication

+switches (quantity)

+ 1x transmitter

## Mounting options/ dimensions

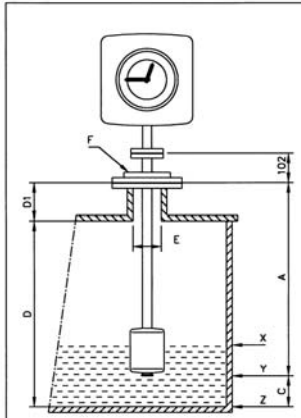

Fig. 05: standard mounting  
on tank nipple

Dim	Description	Value	
A	Guiding tube length		mm
C	Distance guiding tube / tank bottom		mm
D	Tank height (inside)		mm
D1	Height manhole pit		mm
E	Bore of manhole pit		mm
F	Flange size/ -pressure rating		

Scale zero point at :

X	Immersion depth of float	<input type="text"/>
Y	End of guiding tube	<input type="text"/>
Z	Tank bottom	<input type="text"/>

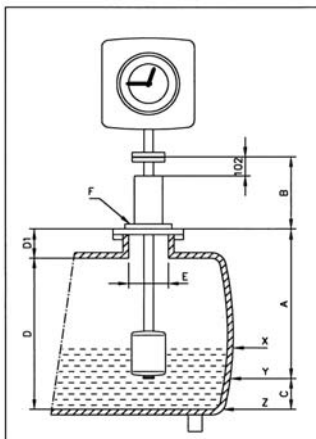

Fig. 06: mounting auf manhole-  
cover with reinforcement

Dim	Description	Value	
A	Guiding tube length		mm
C	Distance guiding tube / tank bottom		mm
D	Tank height (inside)		mm
D1	Height manhole pit		mm
E	Bore of manhole pit		mm
F	Flange size/ -pressure rating		

Scale zero point at :

X	Immersion depth of float	<input type="text"/>
Y	End of guiding tube	<input type="text"/>
Z	Tank bottom	<input type="text"/>

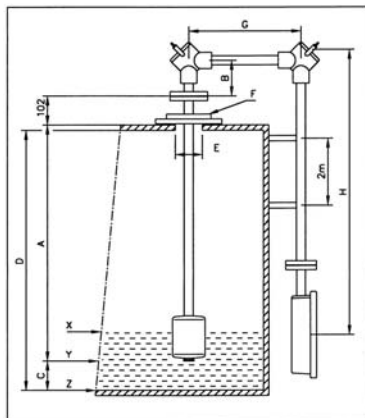

Fig. 07: mounting on the side of  
the tank with lowered  
display

Dim	Description	Value	
A	Guiding tube length		mm
C	Distance guiding tube / tank bottom		mm
D	Tank height (inside)		mm
D1	Height manhole pit		mm
E	Bore of manhole pit		mm
F	Flange size/ -pressure rating		

Scale zero point at :

X	Immersion depth of float	<input type="text"/>
Y	End of guiding tube	<input type="text"/>
Z	Tank bottom	<input type="text"/>

**INTRA-AUTOMATION GmbH**



elektronische Meß-  
und Regelinstrumente

MESS- UND REGELINSTRUMENTE