

DIFFERENTIAL PRESSURE (FLOW) TRANSMITTER

DATA SHEET

FKC...5

The FCX-AIII differential pressure (flow) transmitter accurately measures differential pressure, liquid level, gauge pressure or flow rate and transmits a proportional 4 to 20mA signal. The transmitter utilizes a unique micromachined capacitance silicon sensor with state-of-the-art microprocessor technology to provide exceptional performance and functionality.



FEATURES

- High accuracy up to ±0.04%**
0.065% accuracy as standard, 0.04% accuracy as option.
Fuji's micro-capacitance silicon sensor assures this accuracy for all elevated or suppressed calibration ranges without additional adjustment.
- Minimum environmental influence**
The "Advanced Floating Cell" design which protects the pressure sensor against changes in temperature, static pressure, and overpressure substantially reduces total measurement error in actual field applications.
- Fuji/HART® bilingual communications protocol and FOUNDATION™ fieldbus and Profibus™ compatibility**
FCX-AIII series transmitter offers bilingual communications to speak both Fuji proprietary protocol and HART®. Any HART® compatible devices can communicate with FCX-AIII. Further, by upgrading electronics FOUNDATION™ fieldbus and Profibus™ are also available.
- Application flexibility**
Various options that render the FCX-AIII suitable for almost any process applications include.
 - Full range of hazardous area approvals
 - Built-in RFI filter and lightning arrester
 - 5-digit LCD meter with engineering unit
 - Stainless steel electronics housing
 - Wide selection of materials
- Programmable output Linearization Function**
In addition to Linear and Square Root, output signal can be freely programmable.
(Up to 14 compensated points at approximation.)
- Burnout current flexibility (Under Scale: 3.2 to 4.0mA, Over Scale: 20.0 to 21.6mA)**
Burnout signal level is adjustable using Model FXW Hand Held Communicator (HHC) to comply with NAMUR NE43.
- Dry calibration without reference pressure**
Thanks to the best combination of unique construction of mechanical parts (Sensor unit) and high performance electronics circuit (Electronics unit), reliability of dry calibration without reference pressure is at equal level as wet calibration.

SPECIFICATIONS

Functional specifications

Service: Liquid, gas, or vapour
Static pressure, span, and range limit:

Type	Static pressure [MPa] {bar}	Span limit [kPa] {m bar}		Range limit [kPa] {m bar}
		Min.	Max.	
FKC□11	-0.1 to + 0.2 {-1 to + 2}	0.1 { 1 }	1 { 10 }	+/- 1 { +/- 10 }
FKC□22	-0.1 to + 10 {-1 to + 100}	0.1 { 1 }	6 { 60 }	+/- 6 { +/- 60 }
FKC□23	-0.1 to + 10 {-1 to + 100}	0.32 { 3.2 }	32 { 320 }	+/- 32 { +/- 320 }
FKC□25	-0.1 to + 10 {-1 to + 100}	1.3 { 13 }	130 { 1300 }	+/- 130 { +/- 1300 }
FKC□26	-0.1 to + 10 {-1 to + 100}	5 { 50 }	500 { 5000 }	+/- 500 { +/- 5000 }
FKC□33	-0.1 to + 16 {-1 to + 160}	0.32 { 3.2 }	32 { 320 }	+/- 32 { +/- 320 }
FKC□35	-0.1 to + 16 {-1 to + 160}	1.3 { 13 }	130 { 1300 }	+/- 130 { +/- 1300 }
FKC□36	-0.1 to + 16 {-1 to + 160}	5 { 50 }	500 { 5000 }	+/- 500 { +/- 5000 }
FKC□38	-0.1 to + 16 {-1 to + 160}	30 { 300 }	3000 { 30000 }	+/- 3000 { +/- 30000 }
FKC□43	-0.1 to + 42 {-1 to + 420}	0.32 { 3.2 }	32 { 320 }	+/- 32 { +/- 320 }
FKC□45	-0.1 to + 42 {-1 to + 420}	1.3 { 13 }	130 { 1300 }	+/- 130 { +/- 1300 }
FKC□46	-0.1 to + 42 {-1 to + 420}	5 { 50 }	500 { 5000 }	+/- 500 { +/- 5000 }
FKC□48	-0.1 to + 30 {-1 to + 300}	30 { 300 }	3000 { 30000 }	+/- 3000 { +/- 30000 }
FKC□49	-0.1 to + 30 {-1 to + 300}	500 { 5000 }	20000 { 200000 }	+/- 5000 { +/- 50000 }

Remark : To minimize environmental influence, span should be greater than 1/40 of the max. span in most applications.

- Lower limit of static pressure (vacuum limit) ;
Silicone fill sensor: See Fig. 1
Fluorinated fill sensor: 66kPa abs (500mmHg abs) at temperature below 60°C
- The maximum span of each sensor can be converted to different units using factors as below.
1MPa = 10³KPa = 10bar = 10.19716kgf/cm² = 145.0377psi
1kpa = 10mbar = 101.9716mmH₂O = 4.01463inH₂O

Over range limit: To maximum static pressure limit
Output signal: 4 to 20mA DC (linear or square root) with digital signal superimposed on the 4 to 20mA signal

Power supply: Transmitter operates on 10.5V to 45V DC at transmitter terminals.
 10.5V to 32V DC for the units with optional arrester.

Load limitations: see figure below

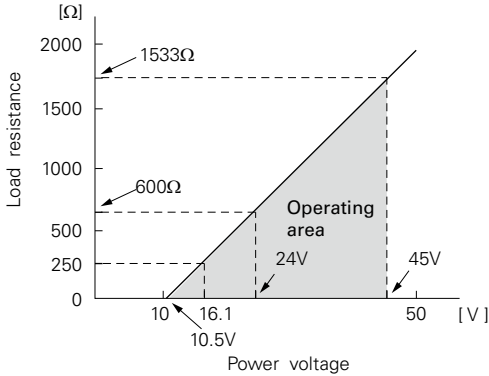

Note: For communication with HHC⁽¹⁾ (Model: FXW), min. of 250 Ω required.

Hazardous locations: (Under an application) SEE TABLE 2

Zero/span adjustment:

Zero and span are adjustable from the HHC⁽¹⁾. Zero and span are also adjustable externally from the adjustment screw (span adjustment is not available with 9th digit code "L, P, M, Q, S, N").

Damping: Adjustable from HHC or local configurator unit with LCD display.
 The time constant is adjustable between 0 to 32 seconds.

Zero elevation/suppression:
 -100% to +100% of URL

Normal/reverse action:
 Selectable from HHC⁽¹⁾

Indication: Analog indicator or 5-digit LCD meter, as specified.

Burnout direction: Selectable from HHC⁽¹⁾
 If self-diagnostic detect transmitter failure, the analog signal will be driven to either "Output Hold", "Output Overscale" or "Output Underscale" modes.

"Output Hold":
 Output signal is hold as the value just before failure happens.

"Output Overscale":
 Adjustable within the range 20.0mA to 21.6mA from HHC⁽¹⁾

"Output Underscale":
 Adjustable within the range 3.2mA to 4.0mA from HHC⁽¹⁾

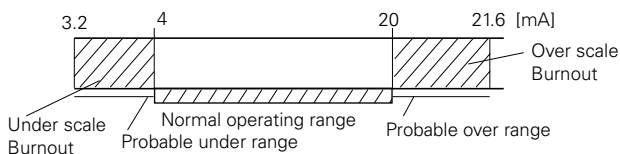

Output limits conforming to NAMUR NE43 by order.

Loop-check output:
 Transmitter can be configured to provide constant signal 3.2mA through 21.6mA by HHC⁽¹⁾.

Temperature limit:
 Ambient: -40 to +85°C
 (-20 to +80°C for LCD indicator)
 (-40 to +60°C for arrester option)
 (-10 to +60°C for fluorinated oil filled transmitters)
 For explosionproof units (flameproof or intrinsic safety), ambient temperature must be within the limits specified in each standard.

Process: -40 to +120°C for silicone fill sensor
 -20 to +80°C for fluorinated oil fill sensor
 Storage: -40 to +90°C

Humidity limit: 0 to 100% RH
Communication: With HHC⁽¹⁾ (Model FXW, consult Data Sheet No. EDS8-47), following items can be remotely displayed or configured.

Note: HHC's version must be higher than 7.0 (or FXW □□□□1-□4), for FCX-AIII.

Local configurator with LCD display (option):
 Local configurator with 3 push button and LCD display can support following items.

Items	By communication with FXW		By local configurator (with 3 push button)	
	Display	Set	Display	Set
Tag No.	✓	✓	✓	✓
Model No.	✓	✓	✓	✓
Serial No. & Software Version	✓	—	✓	—
Engineering unit	✓	✓	✓	✓
Range limit	✓	—	✓	—
Measuring range	✓	✓	✓	✓
Damping	✓	✓	✓	✓
Output mode	Linear	✓	✓	✓
	Square root	✓	✓	✓
Burnout direction	✓	✓	✓	✓
Calibration	✓	✓	✓	✓
Output adjust	—	✓	—	✓
Data	✓	—	✓	—
Self diagnoses	✓	—	✓	—
Printer (In case of FXW with printer option)	✓	—	—	—
External switch lock	✓	✓	✓	✓
Transmitter display	✓	✓	✓	✓
Linearize	✓	✓	—	—
Rerange	✓	✓	✓	✓
Saturate current	✓	✓	✓	✓
Write protect	✓	✓	✓	✓
History	—	—	—	—
	—	—	—	—

Programmable output linearization function:
 Output signal can be characterized with "14 points linear approximation function" from HHC⁽¹⁾.

EMC Conformity: EN61326 CE

(Note) (1) HHC: Hand Held Communicator

Performance specifications for linear output

Reference conditions, silicone oil fill, 316SS isolating diaphragms, 4 to 20mA analog output in linear mode.

Accuracy rating: (including linearity, hysteresis, and repeatability)

Max span above 32kPa model:

For spans greater than 1/10 of URL:

$\pm 0.065\%$ of span or $\pm 0.04\%$ of span (21th digit: H)

For spans below 1/10 of URL:

$\pm \left(0.015 + 0.05 \frac{0.1 \times \text{URL}}{\text{Span}} \right) \%$ of span

Max span 1kPa, 6kPa model:

For spans greater than 1/10 of URL: $\pm 0.1\%$ of span

For spans below 1/10 of URL:

$\pm \left(0.05 + 0.05 \frac{0.1 \times \text{URL}}{\text{Span}} \right) \%$ of span

Stability: $\pm 0.1\%$ of upper range limit (URL) for 10 years for 6th digit code 3, 5, 6, 8 and 9.

Temperature effect:

Effects per 28°C change between the limits of -40°C and +85°C

Range code (6th digit in Code symbols)	Zero shift	Total effect
"1"/1kPa {10mbar} "2"/6kPa {60mbar}	$\pm \left(0.125 + 0.1 \frac{\text{URL}}{\text{Span}} \right) \%$	$\pm \left(0.15 + 0.1 \frac{\text{URL}}{\text{Span}} \right) \%$
"3"/32kPa {320mbar} "5"/130kPa {1300mbar} "6"/500kPa {5000mbar} "8"/3000kPa {30000mbar} "9"/20000kPa {200000mbar}	$\pm \left(0.075 + 0.0125 \frac{\text{URL}}{\text{Span}} \right) \%$	$\pm \left(0.095 + 0.0125 \frac{\text{URL}}{\text{Span}} \right) \%$

Static pressure effect:

Static pressure code (5th digit in Code symbols)	Zero shift (% of URL)
"1" / 1kPa {10m bar} sensor "2" / 6kPa {60 m bar} sensor	$\pm 0.2\%$ / 0.2MPa {2bar} $\pm 0.2\%$ / 3.2MPa {32bar}
"2" "3" "4"	$\pm 0.035\%$ / 6.9MPa {69bar}

Overrange effect:

Static pressure code (5th digit in Code symbols)	Zero shift (% of URL)
"1" / 1kPa {10m bar} sensor "2" / 6kPa {60m bar} sensor	$\pm 0.3\%$ / 0.2MPa {2bar} $\pm 0.1\%$ / 3.2MPa {32bar}
"2" "3" "3" "4"	$\pm 0.1\%$ / 10MPa {100bar} $\pm 0.1\%$ / 16MPa {160bar} FK□3[5,6,8] $\pm 0.15\%$ / 16MPa {160bar} FK□33 $\pm 0.25\%$ / 42MPa {420 bar}

Performance specifications for square root output

Accuracy rating:

Output	Span	
	over 0.1 × URL	below 0.1 × URL
50 to 100%	$\pm 0.065\%$	$\pm (0.015 + 0.05 \times 0.1 \times \text{URL}/\text{Span})\%$
20 to 50%	$\pm 0.163\%$	$\pm 2.5 \times (0.015 + 0.05 \times 0.1 \times \text{URL}/\text{Span})\%$
10 to 20%	$\pm 0.325\%$	$\pm 5 \times (0.015 + 0.05 \times 0.1 \times \text{URL}/\text{Span})\%$

Max span 1kPa, 6kPa model:

Output	Accuracy
50 to 100%	$\pm 0.1\%$
20 to 50%	$\pm 0.25\%$
10 to 20%	$\pm 0.5\%$

Temperature effect:

Effects per 28°C change between the limits of -40°C and +85°C

Range code	Shift at 20% output point
"1" and "2"	$\pm \left(0.375 + 0.25 \frac{\text{URL}}{\text{Span}} \right) \%$ / 28°C
"3" through "9"	$\pm \left(0.24 + 0.03125 \frac{\text{URL}}{\text{Span}} \right) \%$ / 28°C

Low flow cut-off: Customer configurable for any point between 0 to 20% of output

Supply voltage effect:

Less than 0.005% of calibrated span per 1V

Update rate: 60 msec

Step response: (without electrical damping)

Range code (6th digit in code symbols)	Time constant (at 23°C)	Dead time
"1"	0.33 s	0.12 s
"2"	0.3 s	
"3"	0.12 s	
"5" through "8"	0.08 s	

Mounting position effect:

Zero shift, less than 0.12kPa {1.2m bar} for a 10° tilt in any plane.

No effect on span.

This error can be corrected by adjusting Zero.

Dielectric strength:

500V AC, 50/60Hz 1 min., between circuit and earth.

Insulation resistance:

More than 100MΩ at 500V DC.

Internal resistance for external field indicator:

12Ω or less

Physical specifications

Electrical connections:

G1/2, 1/2-14 NPT, Pg13.5, or M20 × 1.5 conduit, as specified. (1 conduit)

Process connections:

1/4-18 NPT or Rc1/4 on 54mm centers, as specified.

Meets DIN 19213.

Process-wetted parts material:

Material code (7th digit in Code symbols)	Process cover	Diaphragm	Wetted sensor body	Vent/drain
V	316 stainless steel(*1)	316L stainless steel	316 stainless steel	316 stainless steel
W	316 stainless steel(*1)	Hastelloy-C	316 stainless steel	316 stainless steel
H	316 stainless steel(*1)	Hastelloy-C	Hastelloy-C lining	316 stainless steel
J	316 stainless steel(*1)	316L stainless steel +Au coating	316 stainless steel	316 stainless steel
M	316 stainless steel(*1)	Monel	Monel lining	316 stainless steel
T	316 stainless steel(*1)	Tantalum	Tantalum lining	316 stainless steel
B	Hastelloy-C lining	Hastelloy-C	Hastelloy-C lining	Hastelloy-C
L	Monel lining	Monel	Monel lining	Monel
U	Tantalum lining	Tantalum	Tantalum lining	Hastelloy-C

Notes: * (1) ASTM CF8M

Remark: Availability of above material design depends on ranges and static pressure. Refer to "Code symbols".

Non-wetted parts material:

Electronics housing: Low copper die-cast aluminum alloy finished with polyester coating (standard), or 316 stainless steel (SCS14 per JIS G5121), as specified.

Bolts and nuts: Cr-Mo alloy (standard), 304 or 316 stainless steel (for static pressure code "1", "2", and "3" only), or 630 stainless steel (for static pressure code "3" and "4" only). Static pressure rating for code "3" with 304 and 316 stainless steel bolts is degraded to 10MPa.

Fill fluid: Silicone oil (standard) or fluorinated oil

Mounting bracket: 304 or 316 stainless steel

Environmental protection:

IEC IP67 and NEMA 6/6P

Mounting:

On 60.5mm(JIS 50A) pipe using mounting bracket, direct wall mounting, or direct process mounting.

Mass(weight):

Transmitter approximately 3.1 to 3.6kg without options.

Add; 0.5kg for mounting bracket

4.5kg for stainless steel housing option

Optional features

Indicator:

A plug-in analog indicator (2.5% accuracy).

An optional 5-digit LCD meter with engineering unit is also available.

Local configurator with LCD display:

An optional 5 digits LCD meter with 3 push buttons can support items as using communication with FXW.

Arrester:

A built-in arrester protects the electronics from lightning surges.

Lightning surge immunity:

4kV (1.2 × 50μs)

Oxygen service:

Special cleaning procedures are followed throughout the process to maintain all process wetted parts oil-free.

The fill fluid is fluorinated oil.

Chlorine service:

The fill fluid is fluorinated oil.

Degreasing:

Process-wetted parts are cleaned, but the fill fluid is standard silicone oil. Not for use on oxygen or chlorine measurement.

NACE specification:

Metallic materials for all pressure boundary parts comply with NACE MR-01-75. ASTM B7M or L7M bolts and 2HM nuts (Class II) are available.

Static pressure rating for code "3" (16 MPa) is degraded to 10MPa.

Vacuum service:

Special silicone oil and filling procedure are applied.

See Fig. 1.

Optional tag plate:

An extra stainless steel tag with customer tag data is wired to the transmitter.

Coating of cell:

Cell's surface is finished with epoxy/polyurethane double coating. Specify if environment is extremely corrosive.

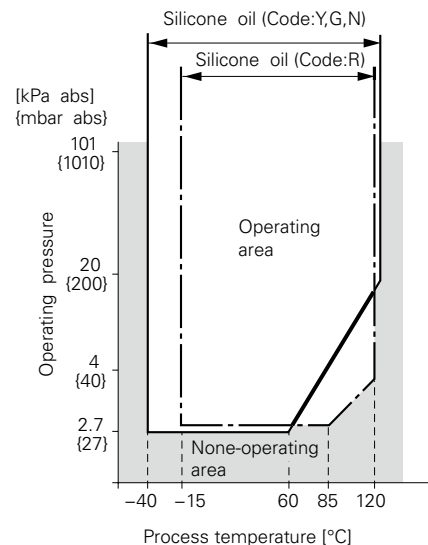

Fig. 1 Relation between process temperature and operating pressure

Digit	Description	Note	1	2	3	4	5	6	7	8	9	10	11	12	13	14	15	21	← Digit No. of code	
9	<Indicator and arrester>		F	K	C					5										
	<u>Indicator</u>	<u>Arrester</u>									A									
	None	None									B									
	Analog, 0 to 100% linear scale	None									C									
	Analog, 0 to 100% sq. root scale (*3)	None	Note 3								D									
	Analog, custom scale	None									E									
	Analog, double scale (Linear and sq. root)	None									F									
	None	Yes									G									
	Analog, 0 to 100% linear scale	Yes									H									
	Analog, 0 to 100% sq. root scale (*3)	Yes	Note 3								K									
	Analog, custom scale	Yes									L									
	Analog, double scale (Linear and sq. root)	Yes									M									
	Digital, 0 to 100%	None									N									
	Digital, custom scale	None									1									
	Digital 0 to 100% square root	None									2									
	Digital, 0 to 100%	Yes									3									
	Digital, custom scale	Yes									4									
	Digital 0 to 100% square root	Yes									5									
	Digital, 0 to 100%	None									6									
	(Local configurator unit with LCD display)	None																		
Digital, custom scale	None																			
(Local configurator unit with LCD display)	None																			
Digital, 0 to 100% square root	None																			
(Local configurator unit with LCD display)	None																			
Digital, 0 to 100%	Yes																			
(Local configurator unit with LCD display)	Yes																			
Digital, custom scale	Yes																			
(Local configurator unit with LCD display)	Yes																			
Digital, 0 to 100% square root	Yes																			
(Local configurator unit with LCD display)	Yes																			
10	<Approvals for hazardous locations>																			
	None (for ordinary locations)										A									
	TIIS, Flameproof (Conduit seal) (*12)	Note 12									B									
	TIIS, Flameproof (Cable gland seal) (*12)	Note 12									C									
	TIIS, Intrinsic safety										G									
	FM, Flameproof (or explosionproof) (*13)	Note 13									D									
	FM, Intrinsic safety and nonincentive										H									
	FM Combined of flameproof and intrinsic safety (*13)	Note 13									V									
	ATEX Flameproof (*14)	Note 14									X									
	ATEX Intrinsic safety										K									
	ATEX Type n										P									
	ATEX Combined of flameproof and intrinsic safety (*14)	Note 14									M									
	IECEx Scheme, Flameproof (*14)	Note 14									R									
	IECEx Scheme, Intrinsic safety										T									
CSA, Flameproof (or explosionproof) (*15)	Note 15									E										
CSA, Intrinsic safety and nonincentive										J										
NEPSI, Flameproof (or explosionproof) (*13)	Note 13									F										
NEPSI, Intrinsic safety (Entity)										S										
NEPSI, Combined of flameproof and intrinsic safety (*13)	Note 13									U										
11	<Vent/ drain and mounting bracket>																			
	<u>Vent/drain</u>	<u>Mounting bracket</u>	<u>Process connection</u>																	
	Standard	None	Specify "A," or "C" for the 7th digit code "B," "L," or "U"	Standard								A								
	Standard	Yes, SUS304		Standard								C								
	Standard	Yes, SUS316		Standard								K								
	Side	None		Standard								D								
	Side	Yes, SUS304		Standard								F								
Side	Yes, SUS316		Standard								L									
12	<Options>																			
	<u>Extra SS tag plate</u>	<u>Stainless steel elec. housing</u>	<u>Coating of cell</u>																	
	None	None	None	Note 4																
	Yes	None	None																	
	None	(*4)	None	Yes																
	Yes		None	Yes																
None	Yes	(*11)	Yes	Note 11																
Yes	Yes		Yes	Note 11																
13	<Special applications and fill fluid>																			
	<u>Treatment</u>	<u>Fill fluid</u>																		
	Standard	Silicone oil																		
	Standard	Fluorinated oil																		
	<u>Degreasing</u>	Silicone oil																		
	Oxygen service	Fluorinated oil (7th digit code "V," "J" only)																		
	Chlorine service	Fluorinated oil (7th digit code "H," "T," "B," "U")																		
	NACE specification	Silicone oil (Not available for 7th digit code "T," "U" and 15th digit code "A," "B")																		
<u>Vacuum service</u>	Silicone oil for vacuum use																			
14	<Sensor O-ring / Gasket>																			
	Teflon (gasket)																		B	

Note 3: (*3) In case of square root output mode, square root scale is not available.

Note 4: (*4) Customer tag number can be engraved on standard stainless steel name plate. If extra tag plate is required, select "Yes".

Digit	Description	Note	1	2	3	4	5	6	7	8	9	10	11	12	13	14	15	21	← Digit No. of code
15	<Bolt/nut> (*8)	Vent Drain plug type	F	K	C					5									
	Cr-Mo alloy socket head cap screw/carbon steel nut	Standard																	
	Cr-Mo alloy hexagon bolt/nut	Standard																	
	NACE bolt/nut (ASTM A193 B7M/A194 2HM) } (*5)	Standard																	
	NACE bolt/nut (ASTM A320 L7M/A194 2HM) }	Standard	Note 5																
	304 stainless steel bolt/304 stainless steel nut (*6)	Standard	Note 6																
630 stainless steel bolt/304 stainless steel nut (*7)	Standard	Note 7																	
316 stainless steel bolt/316 stainless steel nut	Standard																		
21	<Other options> (*9)																		
	High accuracy type (*10)	Note 9																	
	Instruction manual unattached	Note 10																	
	Opposite Vent/Drain Plug Position																		

- Note 5: (*5) Static pressure should be -0.1 to +10MPa {-1 to +100bar}.
- Note 6: (*6) Available for 5th digit code "1", "2", "3". In case of stainless steel bolt with 5th digit code "3", static pressure should be -0.1 to +10MPa {-1 to + 100bar}.
- Note 7: (*7) Available for 5th digit code "3", "4".
- Note 8: (*8) In case of tropical use, select stainless bolts and nuts.
- Note 9: (*9) If other option is not necessary, 21st digit code is blank.
In case of 21st digit code is blank, instruction manual attached.
- Note 10: (*10) Available for 5th digit code "3", "4" and 6th digit code "3" to "8".
- Note 11: (*11) Available for 4th digit code "5" to "9".
- Note 12: (*12) Available for 4th digit code "5", "S".
- Note 13: (*13) Not available for 4th digit code "8", "W".
- Note 14: (*14) Available for 4th digit code "6", "8", "T", "W".
- Note 15: (*15) Available for 4th digit code "6", "T".

ACCESSORIES

- Oval flanges:** (Model FFP, refer to Data Sheet No. EDS6-10)
Converts process connection to 1/2-14 NPT or to Rc1/2; in carbon steel or in 316 stainless steel.
- Equalizing valves:** (Model FFN, refer to Data Sheet No. EDS6-10)
Available in Carbon steel or in 316 stainless steel and in pressure rating 16MPa or 42MPa.
- Hand-held communicator:** (Model FXW, refer to Data Sheet No. EDS 8-47)

ORDERING INFORMATION

- When ordering this instrument, specify:
1. CODE SYMBOLS
 2. Measuring range
 3. Output orientation (burnout direction) when abnormality is occurred in the transmitter.
Hold / Overscale / Underscale
Unless otherwise specified, output hold function is supplied.
 4. Output mode (linear or square root output)
Unless otherwise specified, output mode is linear.
 5. Indication method (indicated value and unit) in case of the actual scale (code D, H, P, S on 9th digit).
 6. Tag No. (up to 14 alphanumeric characters), if required.

OUTLINE DIAGRAM (Unit:mm)

< CODE SYMBOLS : FKC

SW			VM
T	X		J
V			HW

 5 >

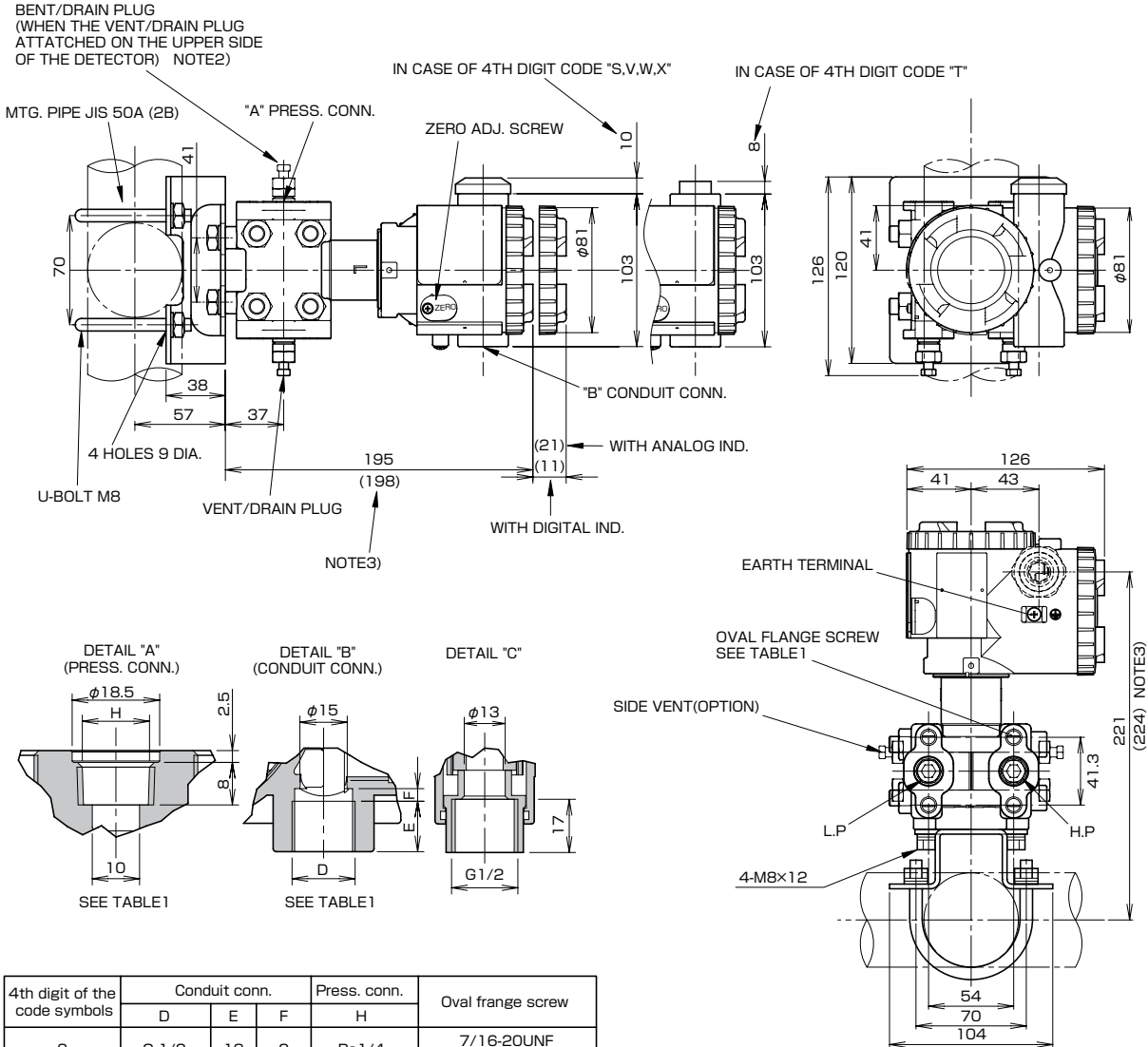
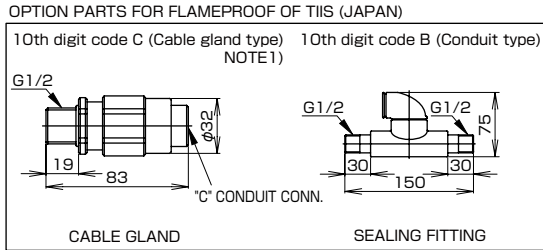

4th digit of the code symbols	Conduit conn.			Press. conn.	Oval frange screw
	D	E	F	H	
S	G 1/2	18	2	Rc1/4	7/16-20UNF SCREW DEPTH15
T	1/2-14NPT	16	4	1/4-18NPT	7/16-20UNF SCREW DEPTH15
V	Pg13.5	10.5	4.5	1/4-18NPT	M10 SCREW DEPTH15
W	M20x1.5	16	4	1/4-18NPT	M10 SCREW DEPTH15
X	Pg13.5	10.5	4.5	1/4-18NPT	7/16-20UNF SCREW DEPTH15

TABLE 1

CONNECTION DIAGRAM

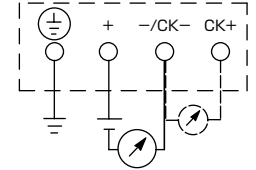

NOTE1) IN CASE OF 10TH CODE "C", φ11 CABLE IS SUITBLE.
 NOTE2) THE PRESSURE CONNECTOR IS LOCATED ON THE DOWN SIDE SURFACE OF THE DETECTOR, WHEN THE VENT/ DRAINPLUG IS ATTACHED ON THE UPPER SIDE OF THE DETECTOR (WHEN THE 21TH DIGIT OF THE CODE SYMBOLS : C).
 NOTE3) WHEN THE 5TH DIGIT OF THE CODE SYMBOLS "1,2,4" or THE 7TH DIGIT OF THE CODE SYMBOLS "C,H,M,T"

< CODE SYMBOLS : FKC

5	8
6	9
7	

VM
JT
HW

 5 >

OPTION PARTS FOR FLAMEPROOF OF TIIS (JAPAN)

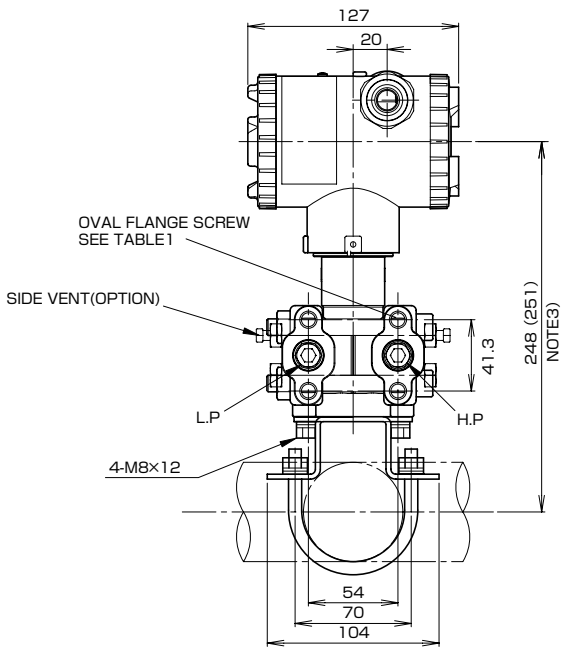
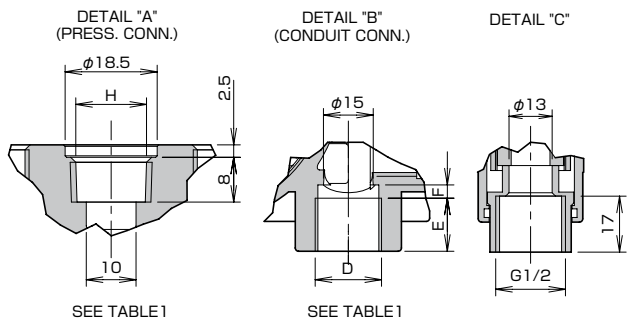
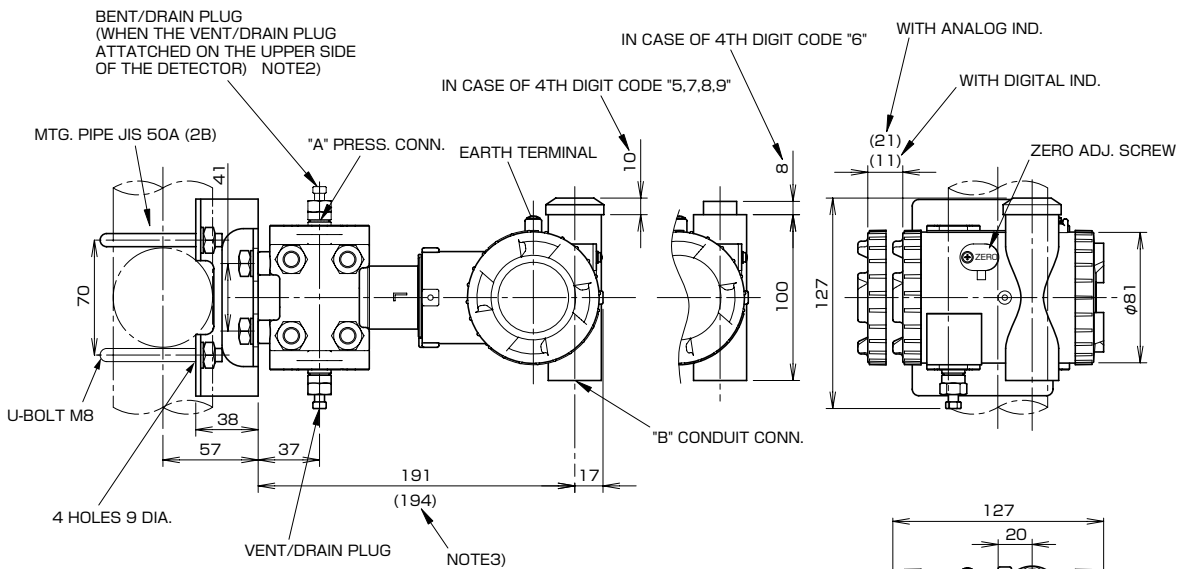
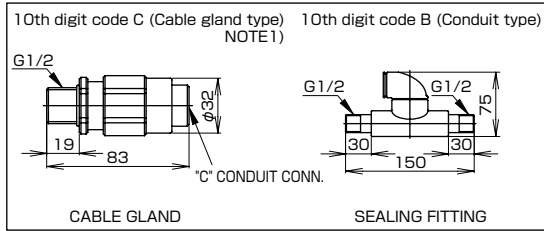

4th digit of the code symbols	Conduit conn.			Press. conn.	Oval frange screw
	D	E	F	H	
5	G 1/2	18	2	Rc1/4	7/16-20UNF SCREW DEPTH 15
6	1/2-14NPT	16	4	1/4-18NPT	7/16-20UNF SCREW DEPTH 15
7	Pg13.5	10.5	4.5	1/4-18NPT	M10 SCREW DEPTH 15
8	M20x1.5	16	4	1/4-18NPT	M10 SCREW DEPTH 15
9	Pg13.5	10.5	4.5	1/4-18NPT	7/16-20UNF SCREW DEPTH 15

TABLE 1

CONNECTION DIAGRAM

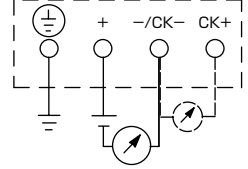

NOTE1) IN CASE OF 10TH CODE "C", phi 11 CABLE IS SUITBLE.
 NOTE2) THE PRESSURE CONNECTOR IS LOCATED ON THE DOWN SIDE SURFACE OF THE DETECTOR. WHEN THE VENT/DRAINPLUG IS ATTACHED ON THE UPPER SIDE OF THE DETECTOR (WHEN THE 21TH DIGIT OF THE CODE SYMBOLS : C).
 NOTE3) WHEN THE 5TH DIGIT OF THE CODE SYMBOLS "1,2,4" OR THE 7TH DIGIT OF THE CODE SYMBOLS "C,H,M,T"

< CODE SYMBOLS : FK

5	8
6	9
7	

B
U
L

 5 >

OPTION PARTS FOR FLAMEPROOF OF TIIS (JAPAN)

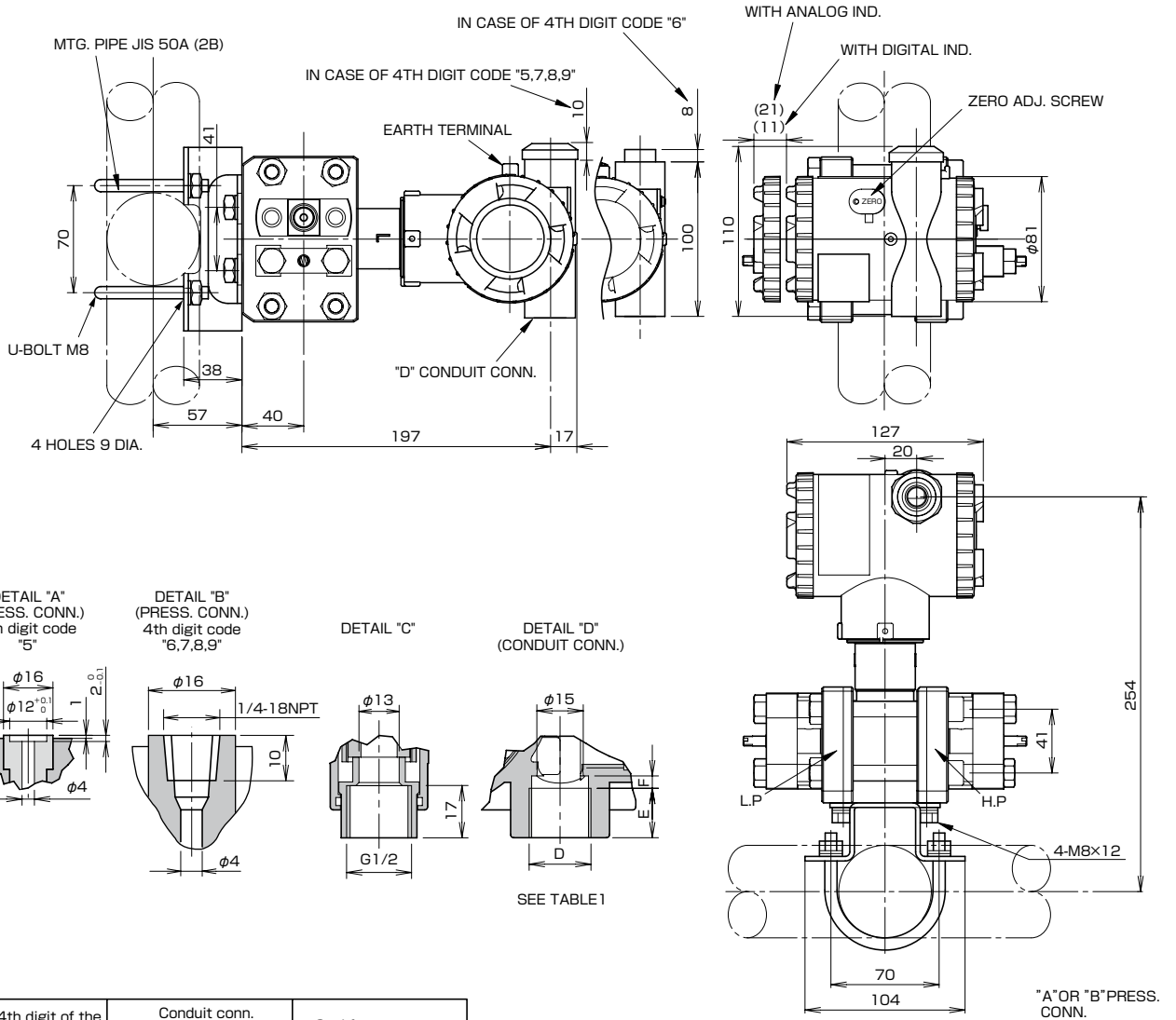
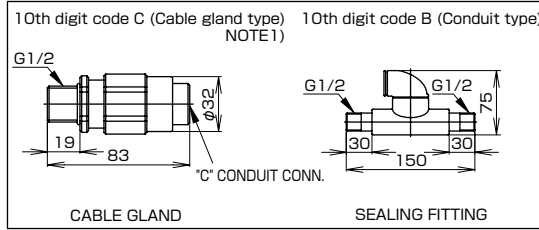

DETAIL "A"
(PRESS. CONN.)
4th digit code
"5"

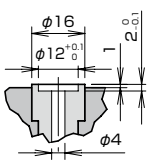

DETAIL "B"
(PRESS. CONN.)
4th digit code
"6,7,8,9"

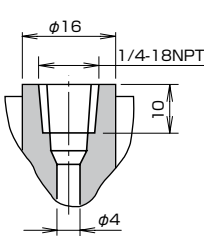

DETAIL "C"

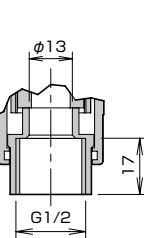

DETAIL "D"
(CONDUIT CONN.)

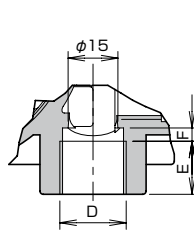

SEE TABLE 1

4th digit of the code symbols	Conduit conn.			Oval frange screw
	D	E	F	
5	G 1/2	18	2	7/16-20UNF SCREW DEPTH 15
6	1/2-14NPT	16	4	7/16-20UNF SCREW DEPTH 15
7	Pg13.5	10.5	4.5	M10 SCREW DEPTH 15
8	M20x1.5	16	4	M10 SCREW DEPTH 15
9	Pg13.5	10.5	4.5	7/16-20UNF SCREW DEPTH 15

TABLE 1

CONNECTION DIAGRAM

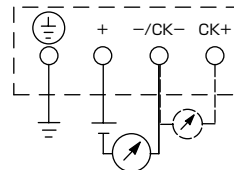

"A" OR "B" PRESS. CONN.

VENT/DRAIN PLUG

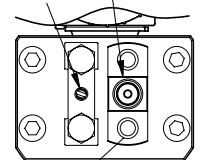

OVAL FLANGE SCREW
SEE TABLE 1

NOTE1) IN CASE OF 10TH CODE "C", φ11 CABLE IS SUITBLE.

TABLE 2

Authorities	Intrinsic safety																					
ATEX	Ex II 1 G Ex ia IIC T5 Tamb = -40°C to +50°C Ex ia IIC T4 Tamb = -40°C to +70°C Entity Parameters: Ui=28V, Ii=94.3mA, Pi=0.66W, Ci=26nF (Without Arrester), Li=0.6mH (Without analog indicator), Ci=36nF (With Arrester), Li=0.7mH (With analog indicator)																					
Factory Mutual (pending)	Class I II III Div.1 Groups A, B, C, D, E, F, G T4 Entity Type 4X <table border="1"> <thead> <tr> <th colspan="2">Model code</th> <th>Tamb</th> </tr> <tr> <th>9th digit</th> <th>13th digit</th> <th></th> </tr> </thead> <tbody> <tr> <td>A,B,C,D,J</td> <td>Y,G,N</td> <td>-40°C to +85°C</td> </tr> <tr> <td>L,P,M,1,2,3</td> <td>Y,G,N</td> <td>-20°C to +80°C</td> </tr> <tr> <td>Q,S,N,4,5,6</td> <td>Y,G,N</td> <td>-20°C to +60°C</td> </tr> <tr> <td>E,F,G,H,K</td> <td>Y,G,N</td> <td>-40°C to +60°C</td> </tr> <tr> <td>-</td> <td>W,A,D</td> <td>-10°C to +60°C</td> </tr> </tbody> </table> Entity Parameters: Vmax=42.4V, Imax=113mA, Pi=1W, Ci=35.98nF, Li=0.694mH	Model code		Tamb	9th digit	13th digit		A,B,C,D,J	Y,G,N	-40°C to +85°C	L,P,M,1,2,3	Y,G,N	-20°C to +80°C	Q,S,N,4,5,6	Y,G,N	-20°C to +60°C	E,F,G,H,K	Y,G,N	-40°C to +60°C	-	W,A,D	-10°C to +60°C
Model code		Tamb																				
9th digit	13th digit																					
A,B,C,D,J	Y,G,N	-40°C to +85°C																				
L,P,M,1,2,3	Y,G,N	-20°C to +80°C																				
Q,S,N,4,5,6	Y,G,N	-20°C to +60°C																				
E,F,G,H,K	Y,G,N	-40°C to +60°C																				
-	W,A,D	-10°C to +60°C																				
CSA	Class I Div.1 Groups A, B, C, D Class II Div.1 Groups E, F, G Class III Div.1 Temp Code T5 Tamb max = +50°C Temp Code T4 Tamb max = +70°C Entity Parameters: Vmax=28V, Imax=94.3mA, Ci=25nF (Without Arrester), Ci=36nF (With Arrester), Li=0.6mH (Without the analog meter), Li=0.7mH (With analog meter)																					
TIIS (pending)	Ex ia IIC T4 Tamb max = +60°C Entity Parameters: Ui=28V, Ii=94.3mA, Pi=0.66W, Ci=38.4nF, Li=0.694mH																					
IECEx Scheme	Ex ia IIC T4 Tamb = -40°C to +70°C Ex ia IIC T5 Tamb = -40°C to +50°C Entity Parameters: Ui=28V, Ii=94.3mA, Pi=0.66W, Ci=26nF (Without Arrester), Li=0.6mH (Without analog indicator), Ci=36nF (With Arrester), Li=0.7mH (With analog indicator)																					
NEPSI	Ex ia IIC T4 Ex d IIB+H ₂ T6 / Ex ia IIC T4 <table border="1"> <thead> <tr> <th colspan="2">Model code</th> <th>Tamb</th> </tr> <tr> <th>9th digit</th> <th>13th digit</th> <th></th> </tr> </thead> <tbody> <tr> <td>A,B,D,J</td> <td>Y,G</td> <td>-40°C to +85°C</td> </tr> <tr> <td>L,P,1,2</td> <td>Y,G</td> <td>-20°C to +80°C</td> </tr> <tr> <td>Q,S,4,5</td> <td>Y,G</td> <td>-20°C to +60°C</td> </tr> <tr> <td>E,F,H,K</td> <td>Y,G</td> <td>-40°C to +60°C</td> </tr> <tr> <td>-</td> <td>W,A,D</td> <td>-10°C to +60°C</td> </tr> </tbody> </table> Entity Parameters: Ui=42.4V, Ii=113mA, Pi=1W, Ci=35.98nF, Li=0.694mH	Model code		Tamb	9th digit	13th digit		A,B,D,J	Y,G	-40°C to +85°C	L,P,1,2	Y,G	-20°C to +80°C	Q,S,4,5	Y,G	-20°C to +60°C	E,F,H,K	Y,G	-40°C to +60°C	-	W,A,D	-10°C to +60°C
Model code		Tamb																				
9th digit	13th digit																					
A,B,D,J	Y,G	-40°C to +85°C																				
L,P,1,2	Y,G	-20°C to +80°C																				
Q,S,4,5	Y,G	-20°C to +60°C																				
E,F,H,K	Y,G	-40°C to +60°C																				
-	W,A,D	-10°C to +60°C																				

Authorities	Flameproof																					
ATEX	Ex II 2 GD Ex d IIC T6 IP66/67 T85°C Tamb = -40°C to +65°C Ex d IIC T5 IP66/67 T100°C Tamb = -40°C to +85°C																					
Factory Mutual	Class I Div.1 Groups B, C, D T6 Type 4X Class II III Div.1 Groups E, F, G T6 Type 4X Tamb max = +60°C																					
CSA	Class I Div.1 Groups C, D Class II Div.1 Groups E, F, G Class III Div.1 (Note) "Seal Not Required" enclosure is allowed.																					
TIIS	Ex do IIB+H ₂ T4 Tamb max = +60°C Maximum process temp. = +120°C																					
IECEx Scheme	Ex d IIC T5 IP66/67 Tamb = -40°C to +85°C Ex d IIC T6 IP66/67 Tamb = -40°C to +65°C																					
NEPSI	Ex d IIB+H ₂ T6 Tamb = -40°C to +60°C																					
Authorities	Type n Nonincendive																					
ATEX (pending)	Ex II 3 GD EEx nL IIC T5 Tamb = -40°C to +50°C EEx nL IIC T4 Tamb = -40°C to +70°C Specific Parameters: Model without arrester: Ui=42.4V, Ii=113mA, Pi=1W, Ci=25.18nF, Li=0.694mH Model with arrester: Ui=32V, Ii=113mA, Pi=1W, Ci=35.98nF, Li=0.694mH EEx nAL IIC T5 Tamb = -40°C to +50°C EEx nAL IIC T4 Tamb = -40°C to +70°C Specific Parameters: Model without arrester: Umax=42.4V, Imax=113mA, Pmax=1W Model with arrester: Umax=32V, Imax=113mA, Pmax=1W																					
Factory Mutual (pending)	Class I II III Div.2 Groups A, B, C, D, F, G T4 Entity Type 4X <table border="1"> <thead> <tr> <th colspan="2">Model code</th> <th>Tamb</th> </tr> <tr> <th>9th digit</th> <th>13th digit</th> <th></th> </tr> </thead> <tbody> <tr> <td>A,B,C,D,J</td> <td>Y,G,N</td> <td>-40°C to +85°C</td> </tr> <tr> <td>L,P,M,1,2,3</td> <td>Y,G,N</td> <td>-20°C to +80°C</td> </tr> <tr> <td>Q,S,N,4,5,6</td> <td>Y,G,N</td> <td>-20°C to +60°C</td> </tr> <tr> <td>E,F,G,H,K</td> <td>Y,G,N</td> <td>-40°C to +60°C</td> </tr> <tr> <td>-</td> <td>W,A,D</td> <td>-10°C to +60°C</td> </tr> </tbody> </table>	Model code		Tamb	9th digit	13th digit		A,B,C,D,J	Y,G,N	-40°C to +85°C	L,P,M,1,2,3	Y,G,N	-20°C to +80°C	Q,S,N,4,5,6	Y,G,N	-20°C to +60°C	E,F,G,H,K	Y,G,N	-40°C to +60°C	-	W,A,D	-10°C to +60°C
Model code		Tamb																				
9th digit	13th digit																					
A,B,C,D,J	Y,G,N	-40°C to +85°C																				
L,P,M,1,2,3	Y,G,N	-20°C to +80°C																				
Q,S,N,4,5,6	Y,G,N	-20°C to +60°C																				
E,F,G,H,K	Y,G,N	-40°C to +60°C																				
-	W,A,D	-10°C to +60°C																				
CSA (pending)	Class I Div.2 Groups A, B, C, D Class II Div.2 Groups E, F, G Class III Div.2 Temp Code T5 Tamb max = +50°C Temp Code T4 Tamb max = +70°C Entity Parameters: Vmax=28V, Ci=25.18nF (Without Arrester), Ci=35.98nF (With Arrester), Li=0.694mH																					

⚠ Caution on Safety

*Before using this product, be sure to read its instruction manual in advance.

Fuji Electric Systems Co., Ltd.

Sales Div. III, International Sales Group Global Business Group

Gate City Ohsaki, East Tower, 11-2, Osaki 1-chome,
Shinagawa-ku, Tokyo 141-0032, Japan

<http://www.fesys.co.jp/eng>

Phone: 81-3-5435-7280, 7281 Fax: 81-3-5435-7425

<http://www.fic-net.jp/eng>