

Table 3.3 Codes for Arithmetic Units

| Code                                | Contents  | Display (setting) Range   | Unit                         | Setting Change            |
|-------------------------------------|---|---|------------------------------|---------------------------|
| U01xx<br> <br>U30xx                 | Arithmetic unit No. 1<br> <br>Arithmetic unit No.30   | -<br> <br>-   | -<br> <br>-                  | -<br> <br>-               |
| Uxx01<br>02<br>03<br>04<br>05<br>06 | Input value (H1)<br>Input value (H2)<br>Input value (P1)<br>Input value (P2)<br>Arithmetic unit output value<br>Arithmetic formula number | -66.9 to 799.9 (%)<br>or<br>0.00 to 99.99 (minute)<br>or<br>0 (OFF), 1 (ON)<br>-699.9 to 799.9(%)<br>or 0 (OFF), (ON) | (%)<br>(minute)<br><br><br>% | x<br>x<br><br>x<br>x<br>- |

Table 3.4 Codes for Variable Parameters

| Code             | Contents  | Display (setting) Range                 | Unit                  | Setting Change |
|------------------|---|---|-----------------------|----------------|
| P0101<br> <br>20 | % type parameter (No. 1)<br> <br>% type parameter (No. 20)      | -699.9 to 799.9<br> <br>-699.9 to 799.9 | %<br> <br>%           | 0<br> <br>0    |
| P0201<br> <br>05 | Time-type parameter (No. 1)<br> <br>Time-type parameter (No. 5) | 0.00 to 99.99<br> <br>0.00 to 99.99     | Minute<br> <br>Minute | 0<br> <br>0    |

Table 3.5 Codes for Broken Line Data

| Code  | Contents                  | Display (setting) Range | Unit | Setting Change |
|-------|---------------------------|-------------------------|------|----------------|
| L01xx | Broken line No. 1         | -                       | -    | (Note)         |
| L02xx | Broken line No. 2         | -                       | -    | -              |
| L03xx | Broken line No. 3         | -                       | -    | -              |
| L0x01 | X axis (X <sub>1</sub> )  | 0.0 to 799.9            | %    | (Note)         |
| 10    | X axis (X <sub>10</sub> ) | 0.0 to 79.9             | %    |                |
| 11    | Y axis (Y <sub>1</sub> )  | 0.0 to 799.9            | %    |                |
| 20    | Y axis (Y <sub>10</sub> ) | 0.0 to 799.9            | %    |                |

Note: Setting can be changed for broken line No. 1 only.

Table 3.6 Codes for Analog Input/Output

|       |                                      |                         |                 |   |
|-------|--------------------------------------|-------------------------|-----------------|---|
| A01xx | Analog input No. 1                   | -                       | -               | - |
| A02xx | Analog input No. 2                   | -                       | -               | - |
| A03xx | Analog input No. 3                   | -                       | -               | - |
| A04xx | Analog input No. 4                   | -                       | -               | - |
| A05xx | Analog input No. 5                   | -                       | -               | - |
| A0x01 | Raw input value                      | -6.0 to 106.9           | %               | x |
| 02    | Value after input processing         | Industrial unit display | Industrial unit | x |
| 03    | Digital filter value                 | 0.0 to 999.9            | Second          | 0 |
| 04    | Industrial unit display (low limit)  | -9999 to 9999           | Industrial unit | 0 |
| 05    | Industrial unit display (high limit) | -9999 to 9999           | Industrial unit | 0 |
| A0601 | Analog output value (No. 1)          | -6.9 to 106.9           | %               | x |
| 02    | Analog output value (No. 2)          | -6.9 to 106.9           | %               | x |
| 03    | Analog output value (No. 3)          | -6.9 to 106.9           | %               | x |
| 04    | Unused                               | "-----" display         | -               | - |
| 05    | Unused                               | "-----" display         | -               | - |

Table 3.6 Codes for Analog Input/Output (Continued)

| Code  | Contents                                  | Display (setting)<br>Range | Unit | Setting<br>Change |
|-------|---|----------------------------|------|-------------------|
| A0701 | 1 V reference input<br>value              | 0.0 (when in<br>test mode) | %    | x                 |
| 02    | 4.6 V reference input<br>value            | 90.0                       | %    | x                 |
| 03    | Feedback value of<br>current output (A01) | -6.9 to 106.9              | %    | x                 |
| 04    | Unused                                    | "-----" display            | -    | -                 |
| 05    | Unused                                    | "-----" display            | -    | -                 |

Table 3.7 Codes for Digital Input/Output

| Code  | Contents               | Display (setting)<br>Range | Unit | Setting<br>Change |
|-------|------------------------|----------------------------|------|-------------------|
| d0101 | Digital input (No. 1)  | 0 (OFF), 1 (ON)            | -    | x                 |
| 02    | Digital input (No. 2)  | 0 (OFF), 1 (ON)            | -    | x                 |
| 03    | Digital input (No. 3)  | 0 (OFF), 1 (ON)            | -    | x                 |
| 04    | Digital input (No. 4)  | 0 (OFF), 1 (ON)            | -    | x                 |
| d0201 | Digital output (No. 1) | 0 (OFF), 1 (ON)            | -    | x                 |
| 02    | Digital output (No. 2) | 0 (OFF), 1 (ON)            | -    | x                 |
| 03    | Digital output (No. 3) | 0 (OFF), 1 (ON)            | -    | x                 |

Table 3.8 Table of Arithmetic, Logical, and Operational Functions

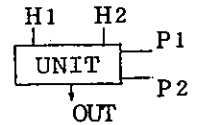

| No. | Name                          | Symbol | Internal Terminals |    |    |    | Output | Dynamic Area | Processing Time Factor (Non-dimensional) | Default Values |          |          | Remarks        |
|-----|-------------------------------|--------|--------------------|----|----|----|--------|--------------|--|----------------|----------|----------|----------------|
|     |                               |        | H1                 | H2 | P1 | P2 |        |              |  | H2             | P1       | P2       |                |
| 1   | Addition                      | ADD    | P                  | P  | P  | P  | P      | N            | 90                                       | 0%             | 100%     | 100%     |                |
| 2   | Subtraction                   | SUB    | P                  | P  | P  | P  | P      | N            | 90                                       | 0%             | 100%     | 100%     |                |
| 3   | Multiplication                | MUL    | P                  | P  | -  | -  | P      | N            | 90                                       | 100%           |          |          |                |
| 4   | Division                      | DVD    | P                  | P  | P  | -  | P      | N            | 83                                       | 100%           | 0%       |          |                |
| 5   | Absolute value                | ABS    | P                  | -  | -  | -  | P      | N            | 3  |                |          |          |                |
| 6   | Square-root extraction        | SQR    | P                  | -  | P  | -  | P      | N            | 136                                      |                | 0%       |          |                |
| 7   | Maximum value                 | MAX    | P                  | P  | P  | P  | P      | N            | 8  | 0%             | 0%       | 0%       |                |
| 8   | Minimum value                 | MIN    | P                  | P  | P  | P  | P      | N            | 8  | 100%           | 100%     | 100%     |                |
| 9   | 4-point addition              | SGM    | P                  | P  | P  | P  | P      | N            | 27                                       | 0%             | 0%       | 0%       |                |
| 10  | High selector                 | HSE    | P                  | P  | -  | -  | P      | N            | 3  | 0%             |          |          |                |
| 11  | Low limiter                   | LLM    | P                  | P  | -  | -  | P      | N            | 3  | 0%             |          |          |                |
| 12  | Low selector                  | LSE    | P                  | P  | -  | -  | P      | N            | 3  | 100%           |          |          |                |
| 13  | High limiter                  | HLM    | P                  | P  | -  | -  | P      | N            | 3  | 100%           |          |          |                |
| 14  | High monitor                  | HMS    | P                  | P  | -  | P  | F      | N            | 6  | 100%           |          | 0%       |                |
| 15  | Low monitor                   | LMS    | P                  | P  | -  | P  | F      | N            | 6  | 0%             |          | 0%       |                |
| 16  | Deviation monitor             | DMS    | P                  | P  | P  | P  | F      | N            | 16                                       | 0%             | 100%     | 0%       |                |
| 17  | Deviation rate limiter        | DRL    | P                  | P  | P  | -  | P      | Y            | 130                                      | 0%             | 0%       |          |                |
| 18  | Deviation rate monitor        | DRM    | P                  | P  | P  | P  | F      | Y            | 45                                       | 0%             | 0%       | 0%       |                |
| 19  | Manual output                 | MAN    | P                  | P  | -  | -  | P      | N            | 8  | 0%             |          |          |                |
| 20  | Controller #1                 | PID1   | P                  | P  | P  | F  | F      | N            | 371                                      | 0%             | 0%       | OFF      |                |
| 21  | Controller #2                 | PID2   | P                  | P  | P  | F  | F      | N            | 371                                      | 0%             | 0%       | OFF      |                |
| 22  | Dead time                     | DED    | *                  | -  | T  | -  | P      | Y            | 59                                       |                | 0 minute |          |                |
| 23  | Lead/lag                      | L/L    | P                  | -  | T  | T  | P      | Y            | 283                                      |                | 0 minute | 0 minute |                |
| 24  | Derivative (differentiation)  | LED    | P                  | -  | T  | T  | P      | Y            | 347                                      |                | 0 minute | 0 minute |                |
| 25  | Moving average                | MAV    | P                  | -  | T  | -  | P      | Y            | 143                                      |                | 0 minute |          |                |
| 26  | Flip-Flop                     | RS     | F                  | F  | -  | -  | F      | N            | 1  | OFF            |          |          |                |
| 27  | Logical product               | AND    | F                  | F  | -  | -  | F      | N            | 1  | OFF            |          |          |                |
| 28  | Logical sum                   | OR     | F                  | F  | -  | -  | F      | N            | 1  | OFF            |          |          |                |
| 29  | Exclusive OR                  | XOR    | F                  | F  | -  | -  | F      | N            | 1  | OFF            |          |          |                |
| 30  | Invert                        | NOT    | F                  | -  | -  | -  | F      | N            | 1  |                |          |          |                |
| 31  | 2-point switch                | SW     | P                  | P  | F  | -  | P      | N            | 1  | 0%             | OFF      |          |                |
| 32  | Bumpless transfer switching   | SPT    | P                  | P  | F  | P  | P      | Y            | 45                                       | 0%             | OFF      | 100%     |                |
| 33  | Timer                         | TIM    | F                  | -  | T  | -  | F      | Y            | 28                                       |                | 0 minute |          |                |
| 34  | Cumulative pulse output       | CPO    | F                  | P  | P  | -  | F      | Y            | 72                                       | 100%           | 100%     |          |                |
| 35  | Ramp wave generation          | RMP    | F                  | F  | T  | -  | F      | Y            | 173                                      | OFF            | 0 minute |          |                |
| 36  | Pulse width modulation        | PWM    | P                  | -  | T  | -  | F      | Y            | 108                                      |                | 0 minute |          |                |
| 37  | Broken line table #1          | TBL1   | P                  | -  | -  | -  | P      | N            | 136                                      |                |          |          |                |
| 38  | Broken line table #2          | TBL2   | P                  | -  | -  | -  | P      | N            | 136                                      |                |          |          |                |
| 39  | Broken line table #3          | TBL3   | P                  | -  | -  | -  | P      | N            | 136                                      |                |          |          |                |
| 40  | Inverted broken line table #1 | TBR1   | P                  | -  | -  | -  | P      | N            | 136                                      |                |          |          |                |
| 41  | Inverted broken line table #2 | TBR2   | P                  | -  | -  | -  | P      | N            | 136                                      |                |          |          |                |
| 42  | Inverted broken line table #3 | TBR3   | P                  | -  | -  | -  | P      | N            | 136                                      |                |          |          |                |
| 43  | Parameter modulation #1       | PMD1   | P                  | -  | F  | -  | P      | N            | 123                                      |                | OFF      |          | EXT. No.: with |
| 44  | Parameter modulation #2       | PMD2   | P                  | -  | F  | -  | P      | N            | 123                                      |                | OFF      |          | EXT. No.: with |
| 45  | Mode select                   | MOD    | P                  | F  | F  | F  | -      | N            | 2  | OFF            | OFF      | OFF      |                |

P: Percent-type data      Y: Used  
 T: Time-constant-type data    N: Unused  
 F: ON/OFF-type data

### 3.2.3 Alarm Display and Self-diagnosis Display

#### (1) Alarm Display

Alarms (PVH, PVL, DEV LARGE) detected by the PID arithmetic unit are displayed with codes at the code part on the data setting unit. (Figure 3.3)

- o For this display, press the  key to make the display the OFF state (alarm/diagnosis display state).

#### (2) Self-diagnosis Display

When an abnormal state is detected by the self-diagnosis function of KMM, the contents of the abnormality are displayed with codes at the data part on the data setting unit. (Figure 3.3)

- o When an abnormal state of diagnosis B group (which causes operation stop of CPU), display is changed to that of diagnosis codes even when it has been in the ON state (the operation display state).

- o When an abnormal state of diagnosis A group is detected, the contents of the abnormality are displayed as the



key is pressed to turn OFF the display, as is the case for alarm display.

- o Diagnosis A group (the instrument becomes the interlock manual mode.)

Calculation overflow (each unit)  
Calculation overload  
Input abnormal

- o Diagnosis B group (the instrument becomes the standby mode.)

ROM abnormal

RAM abnormal

Sample time abnormal

A/D conversion abnormal

Current output (A01) feedback abnormal

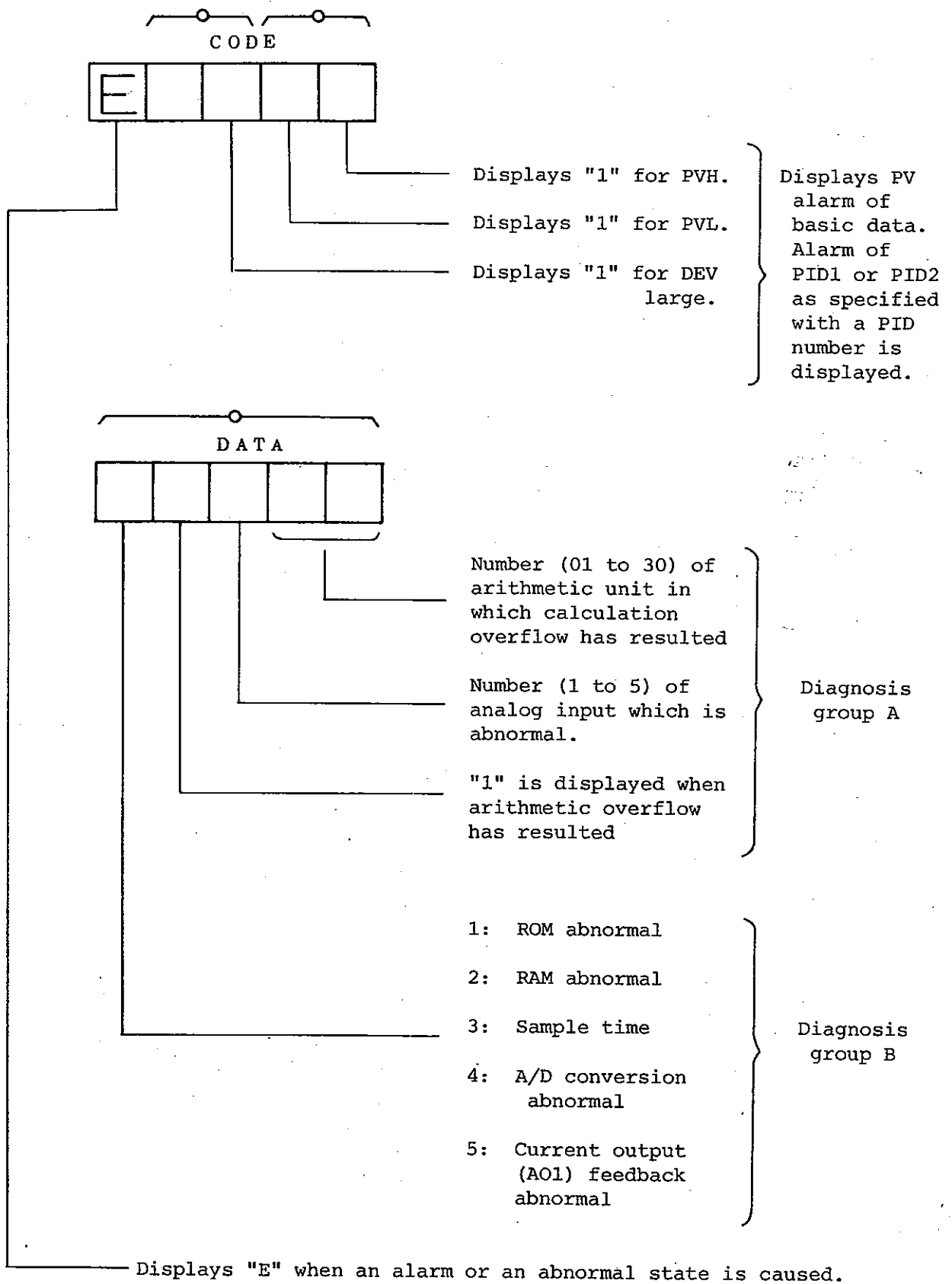

Figure 3.3 Alarm Display and Self-diagnosis Display

(3) Maintenance

The KMM requires no particular routine maintenance work. With its self diagnosis functions, failures of cards can be identified as mentioned in the following. Replace the failed cards with spare ones.

| Setting unit display   | Card to be replaced |   |                 |
|--|---------------------|---|-----------------|
| <table border="1"><tr><td>E</td></tr><tr><td>1</td></tr></table> | E                   | 1 | CPU card        |
| E  |                     |   |                 |
| 1  |                     |   |                 |
| <table border="1"><tr><td>E</td></tr><tr><td>2</td></tr></table> | E                   | 2 | CPU card        |
| E  |                     |   |                 |
| 2  |                     |   |                 |
| <table border="1"><tr><td>E</td></tr><tr><td>3</td></tr></table> | E                   | 3 | CPU card        |
| E  |                     |   |                 |
| 3  |                     |   |                 |
| <table border="1"><tr><td>E</td></tr><tr><td>4</td></tr></table> | E                   | 4 | IOC card        |
| E  |                     |   |                 |
| 4  |                     |   |                 |
| <table border="1"><tr><td>E</td></tr><tr><td>5</td></tr></table> | E                   | 5 | IOC card (Note) |
| E  |                     |   |                 |
| 5  |                     |   |                 |
| <table border="1"><tr><td>E</td></tr><tr><td>9</td></tr></table> | E                   | 9 | CPU card        |
| E  |                     |   |                 |
| 9  |                     |   |                 |

Note: When 

|   |
|---|
| E |
| 5 |

 is displayed, a possible cause is open-circuit-

ing of the external wiring of the current output circuit (loosening of a screw, etc.). Check at first the circuit for open-circuiting.

Before replacing cards, turn off the main power or pull out the power supply unit.

### 3.3 Auxiliary Switches

The KMM has six auxiliary switches.

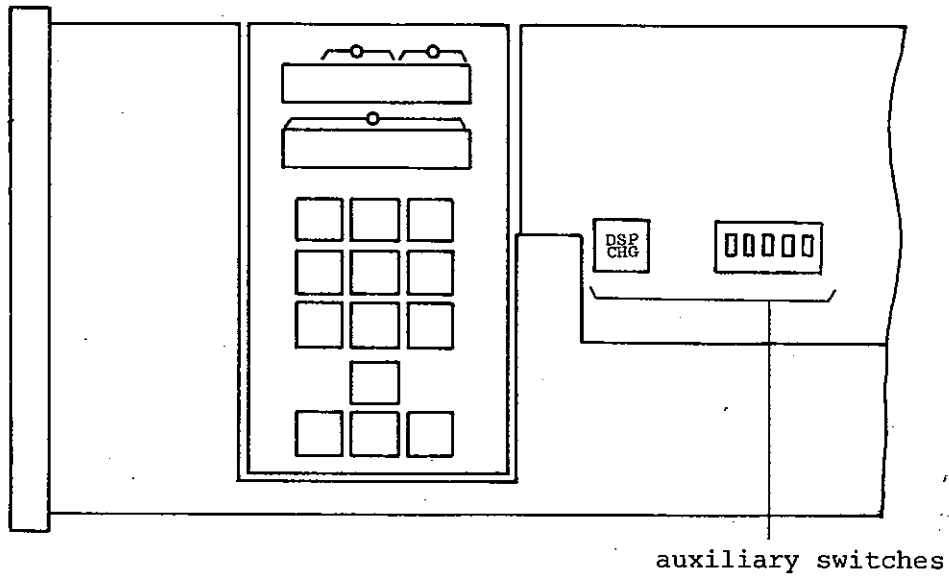







Figure 3.4 Auxiliary Switches

Table 3.10 Functions of Auxiliary Switches

| Switch  | Name                  | Description   |
|---|-----------------------|---|
|  | Display change switch | This pushbutton switch changes the signals indicated by the meter on the front panel of the instrument. The signals which are displayed while this switch is kept depressed differ by the type of controller. |

| Switch   | Name   | Description  |
|--|--|--|
| <p>OFF</p>  <p>ON</p>   | <p>Data entry enable switch</p>                | <p>This switch enables entry of data to change various parameters by means of data setting unit. For data entry or change, set this switch in the ON state and press the key of the data setting unit.</p>   |
| <p>OFF</p>  <p>ON</p>   | <p>Initial start switch</p>                    | <p>If the power switch is turned on with this switch set in the ON state, the parameters which are set by the data setting unit are erased and the initial values which have been set by the program loader are read into the instrument.</p>        |
| <p>OFF</p>  <p>ON</p> | <p>Write enable switch</p>                     | <p>This switch select between write inhibit (OFF) and write enable (ON) of data from a host computer through a communications linkage. To enable writing, set this switch in the ON state; to inhibit writing, set this switch in the OFF state.</p> |
| <p>OFF</p>  <p>ON</p> | <p>Direct/reverse action selector switch 1</p> | <p>This switch specifies the control action of PID1.</p> <p>ON: Direct action (Output increase when SP &lt; PV.)</p> <p>OFF: Reverse action (Output increases when SP &gt; PV.)</p>  |
| <p>OFF</p>  <p>ON</p> | <p>Direct/reverse action selector</p>          | <p>This switch specifies the control action of PID2. The functions are identical with those of the above switch 1.</p>   |

### 3.4 Standby Manual Unit

When an abnormal state of diagnosis B group (which causes CPU stop) is detected by the self-diagnosis function of KMM, the instrument is automatically switched into the standby mode and the output current of KMM can be controlled with the standby manual unit. Two types of standby manual units are available as follows:

- (1) Preset type: Delivers the preset output value.
- (2) Follow-up type: Maintains the output value which existed immediately before switching.

#### 3.4.1 Operation of Preset Type Standby Manual Unit

##### (1) Normal Operation

- ① Set the STANDBY/NORMAL switch of the standby manual unit in the NORMAL state (KMM output state)
- ② Set the desired preset value with the output control knob.
- ③ Even when the controller (main unit) has no abnormality, the STANDBY/NORMAL switch may be set to the STANDBY state so that the analog output (AO1) is unconditionally get to that of the standby manual unit.  
In this case, the controller (main unit) becomes the IM mode (interlock manual mode) and the output of the controller (main unit) follows that of the standby manual unit. Due to this, no bumps are produced in the output even when the switch is returned to the normal mode.

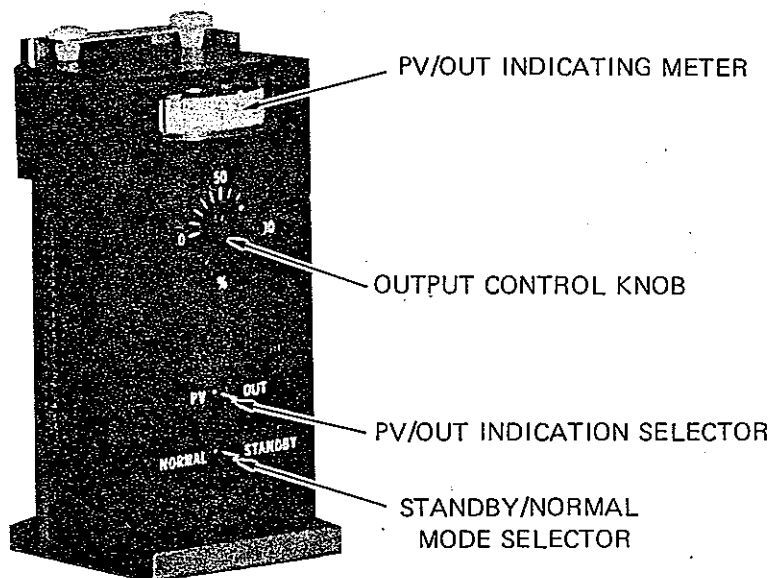

Figure 3.5 Preset-type Standby Manual Unit

(2) Operating Procedure when Abnormal State is Caused

- ① When an abnormal state is detected, the instrument is automatically switched into the standby mode and it delivers the preset output value. The CPU. F lamp on the front panel of the instrument indicates that the operation has been changed to the standby mode.
- ② Pull out the KMM main unit, pushing upward the bracket at the front bottom of the instrument. The main unit will stop at a half-way position as it is caught by the latch. Release the latch and pull out the KMM main unit.
- ③ For repair or replacement of the KMM main unit, set the STANDBY/NORMAL selector switch in the STANDBY state, release the clamping latch of the standby manual unit, and remove the standby manual unit from the KMM main unit. The standby manual unit remains in the case. (Figure 3.6)
- ④ Face to the front the control section of the standby manual unit. The standby manual can be installed with it front to this side into the case.  
For operation with the standby manual unit, throw the PV/OUT indication selector switch to the PV side (raw analog input is displayed) and control the output with the output control knob.

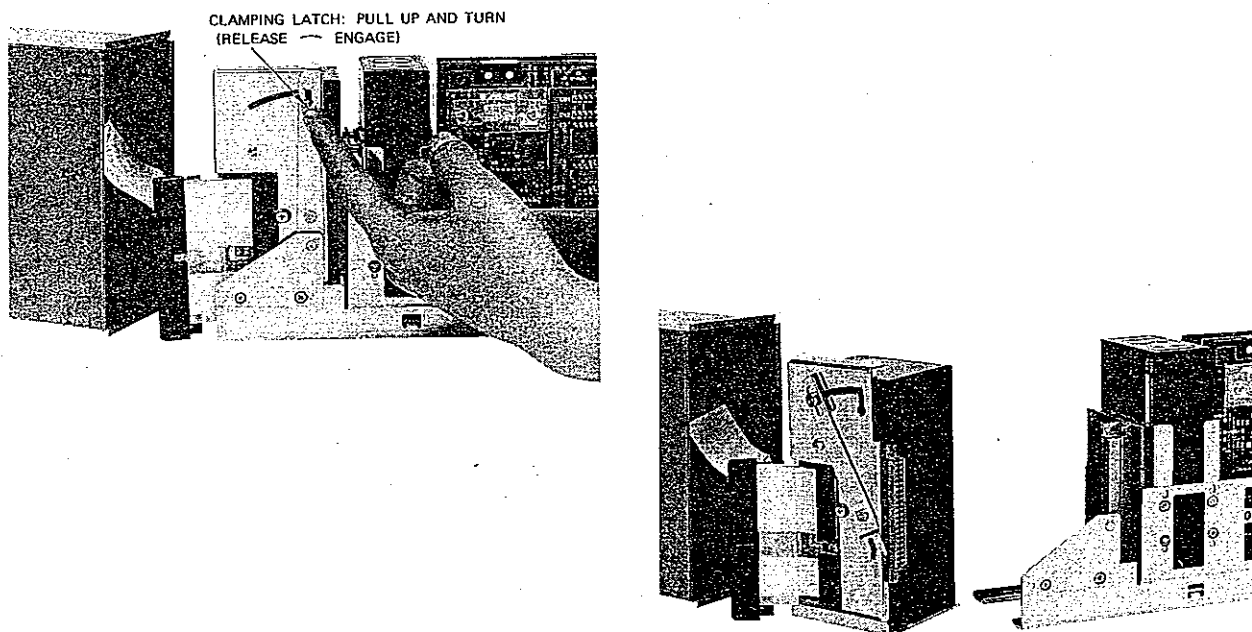

Figure 3.6 Installation and removal of standby manual unit

(3) Repair

- ① After repairing or replacing the KMM main unit basing on the error code displayed on the data setting unit, connect it to the standby manual unit (Note).
- ② Return the STANDBY/NORMAL switch to the NORMAL position.
- ③ The KMM main unit in this case will be in the interlock manual mode. Reset it to the normal operation mode by pressing the R (RST) button on the instrument front panel.

Note: In order to protect the instrument against the rush current which may flow when the unit is connected and may damage the instrument, connect the unit in the state that the power unit of the KMM main unit is removed, and then insert the power unit in the original position.



3.4.2 Operation of Follow-up Type Standby Manual

(1) Normal Operation

- 1 Set the STANDBY/NORMAL switch of the standby manual unit in the NORMAL state (controller output state).
- 2 Even when the controller (main unit) has no abnormality, the STANDBY/NORMAL switch may be set to the STANDBY state so that the analog output (A01) is unconditionally set to that of the standby manual unit.

In this case, the controller (main unit) becomes the IM mode (interlock manual mode) and the output of the controller (main unit) follows that of the standby manual unit. Due to this, no bumps are produced in the output even when the switch is returned to the normal mode.

(2) Operating Procedure When Abnormal State is Caused

- ① When an abnormal state is detected, the instrument is automatically switched into the standby mode and it delivers the controller output which existed immediately before the abnormal state has occurred. The CPU. F lamp on the front panel of the instrument indicates that the operation has been changed to the standby mode.
- ② The output of the standby manual unit can be adjusted either with the output control buttons  on the instrument front panel or with the output control buttons  of the standby manual unit.
- ③ Pull out the KMM main unit, pushing upward the bracket at the front bottom of the instrument. The main unit will stop at a half-way position as it is caught by the latch. Release the latch and pull out the KMM main unit.
- ④ For repair or replacement of the KMM main unit, set the STANDBY/NORMAL selector switch in the STANDBY state, release the clamping latch of the standby manual unit, and remove the standby manual unit from the KMM main unit. The standby manual unit will remain the case. (Figure 3.7)

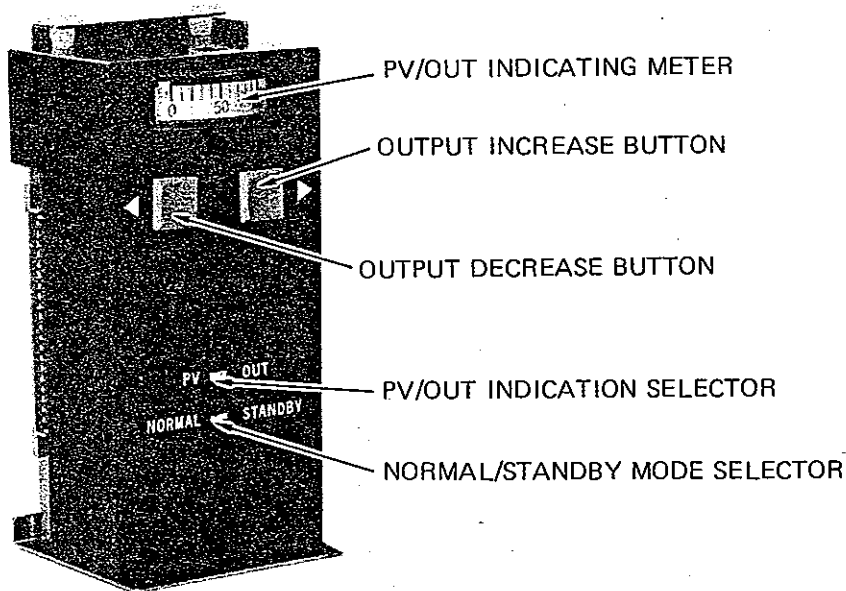

Figure 3.7 Follow-up Type Standby Manual Unit

- ⑤ Face to the front the control section of the standby manual unit. The standby manual can be installed with it front to this side into the case. For operation with the standby manual unit, throw the PV/OUT indication selector switch to the PV position (raw analog input is displayed) and control the output with the output control knob.

(3) Repair

- ① After repairing or replacing the KMM main unit, connect it to the standby manual unit (note).
- ② Return the STANDBY/NORMAL switch to the NORMAL position.
- ③ The KMM main unit in this case will be in the interlock manual mode. Reset it to the normal operation mode by pressing the R (RST) button on the instrument front panel.

Note: In order to protect the instrument against the rush current which may flow when in the unit is connected and may damage the instrument, connect the unit in the state that the power unit of the KMM main unit is removed, and then insert the power unit in the original position.

3.4.3 Replacement of Standby Manual Unit

(1) Power Supply

- ① Whenever possible, provide a separate power supply line (with dedicated fuse and switch) separately from that of the main unit.
- ② If it is unavoidable to use the same power supply line for both main unit and standby manual unit, provide a dedicated fuse and a switch for the standby manual unit.

(2) Replacement

To replace or insert/remove the standby manual unit when the main unit is in the energized state, turn off the power of the standby manual unit.

### 3.5 Status Display LED's

Four LED's (light emitting diodes) for operating status display of KMM are installed on the printed circuit board in KMM. (Figure 3.8)

Table 3.8 Status Display LED's

| LED No. | Name                      | Description  |
|---------|---------------------------|--|
| 1       | CPU reset display         | Lights when in CPU reset.  |
| 2       | Watchdog time out display | Lights when in watchdog time out.  |
| 3       | Sampling display          | Indicates sampling execution. Lights and goes off with the sampling periods. |

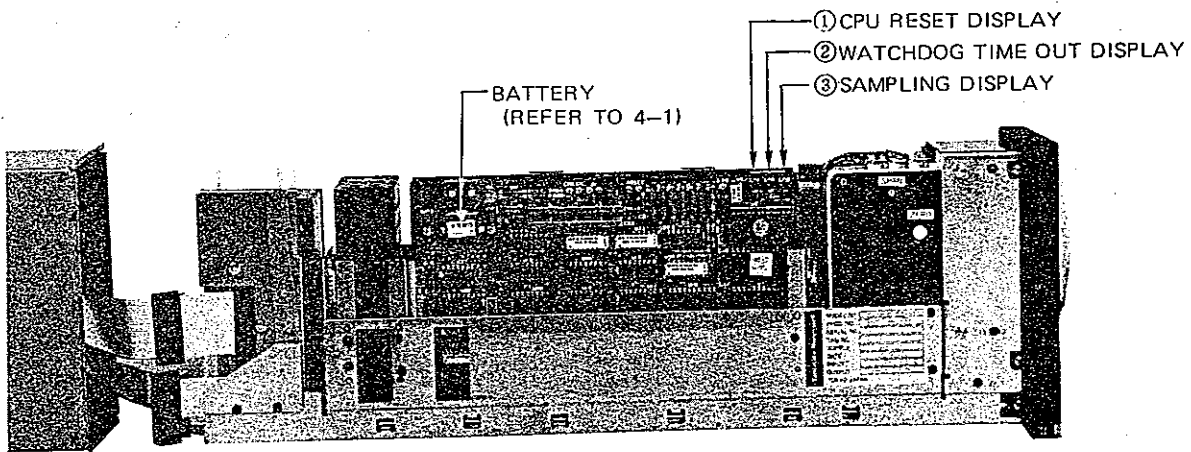

Figure 3.8 Status Display LED's

## 4. PREPARATIONS FOR OPERATION OF KMM

### 4.1 Start-up Procedure

To start up the controller, observe the following procedure.

#### ① Preparations

Check that the auxiliary switches are correctly set. If a standby manual unit is provided, set its STANDBY/NORMAL mode selector switch in the NORMAL position. If the standby manual unit is of the preset type, set also the preset output value by operating the output knob. Remove the insulation sheet from the surface of the battery. (Refer to Figure 3.8).

#### ② Turning on the power

Turn the power of the KMM. (Turn on the power of the standby manual unit also.) The KMM will become the interlock manual mode.

#### ③ Checking the operation data

By means of the data setting unit, check that the analog input values (digital input values), variable parameters, and other control data needed for operation are correctly set. Change data setting as required.

#### ④ Press the R (RST) button to release the interlock state.

Perform output adjustment, mode setting and other operating procedure for normal operation.

### 4.2 Battery Replacement

- (1) The CPU card has a back up battery to protect data. Replace the battery before its expiration date. The date is shown on the battery card. (See Figure 4:1)
- (2) Be sure to keep instrument power "on" when replacing the battery. Note that data will be lost if you disconnect the battery card from the CPU card when instrument power is off. (When data is lost thus, reload data employing a data setting unit.)
- (3) The battery card is fixed with two screws to the studs which are fixed to the CPU card with two screws. To detach the battery card, remove the former two screws.
- (4) Install a new battery in the correct polarity (observe that the "+" and "-" marks of the battery card and CPU card conform). After installing the battery card, make sure that all of the four screws mentioned in Item (3) are securely tightened and not loose since the studs act also as leadwires for the battery power source.

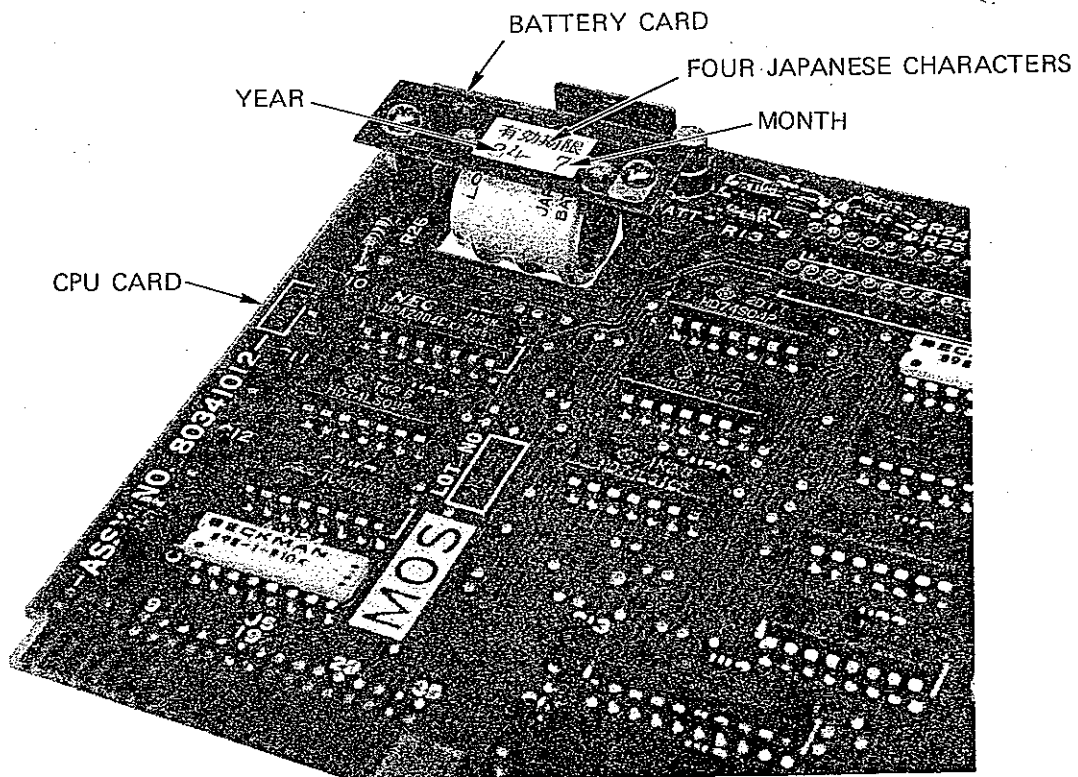
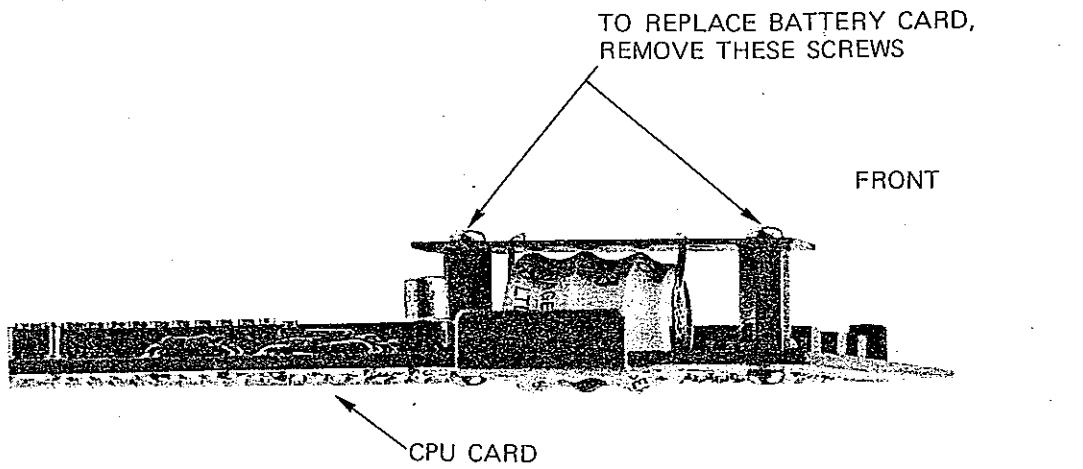

Figure 4.1 Location of Battery Card

### 4.3 Electrical Connections

#### 4.3.1 Connection of Analog Input Signal

The analog input signal is a voltage signal of 1 to 5V DC. The voltage input terminals are of a differential type, with a positive (+) terminal and a negative (-) terminal for each input. Connections between units are shown in the following.

- (1) Connection between SSC Line Instruments.

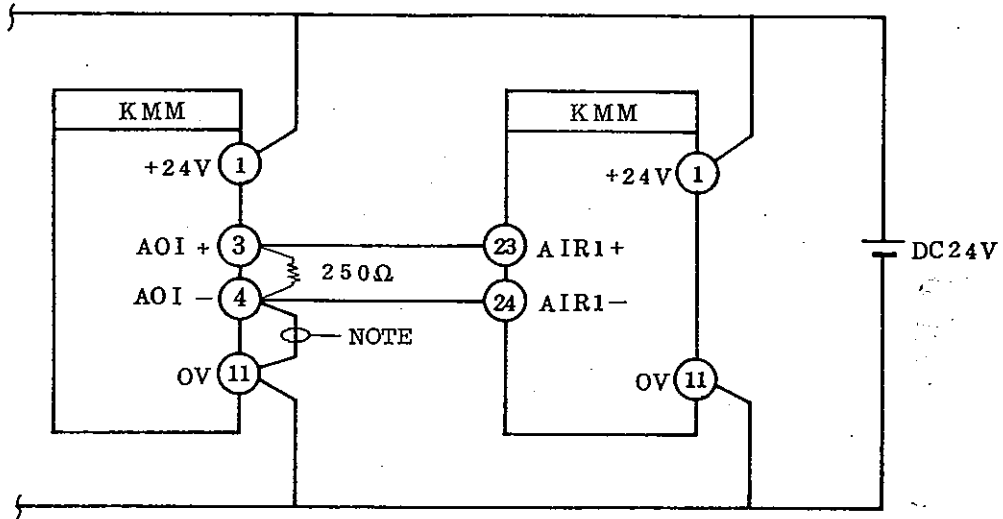

\* This jumper is not required if this connection is done elsewhere, such as at Wiring Block.

Figure 4.2 Connection Between SSC Line Instruments.

- (2) Connections between KMM and instrument of other power supply (DC system)

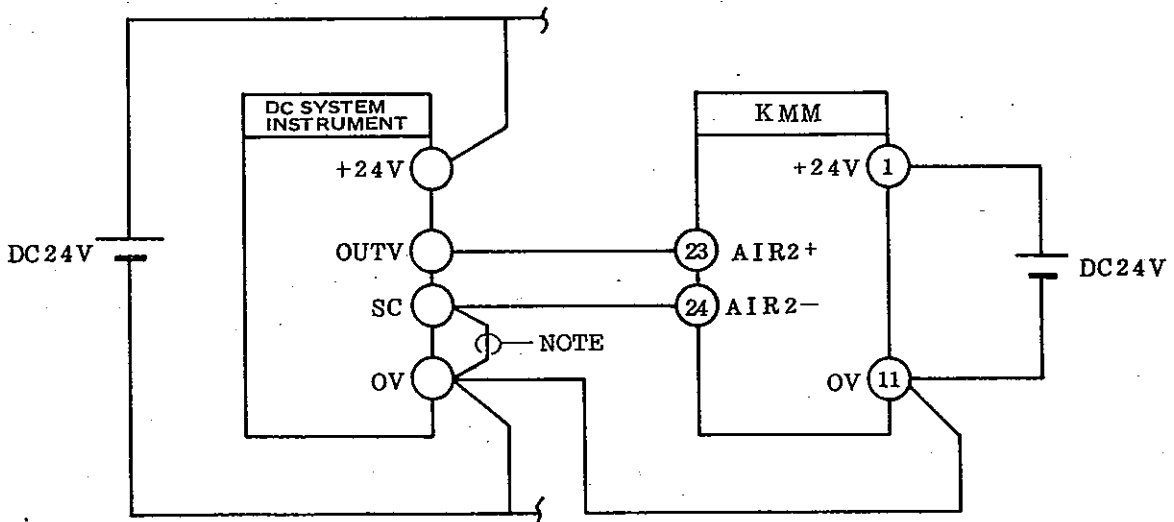

\* This jumper is not required if this connection is done elsewhere, such as at a Wiring Block.

Figure 4.3 Connections Between KMM and Instrument of Other Power Supply System (DC system)

- (3) Connections between KMM and instrument of other power supply (AC system)

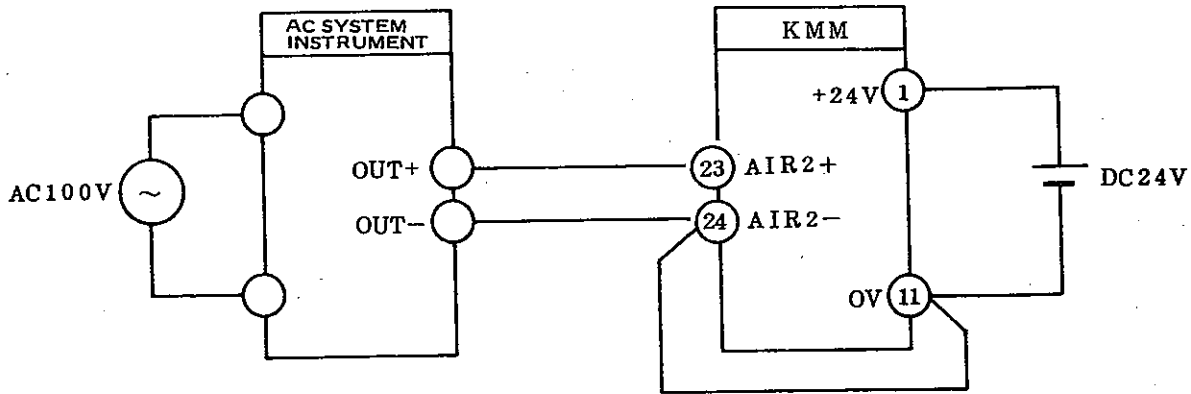
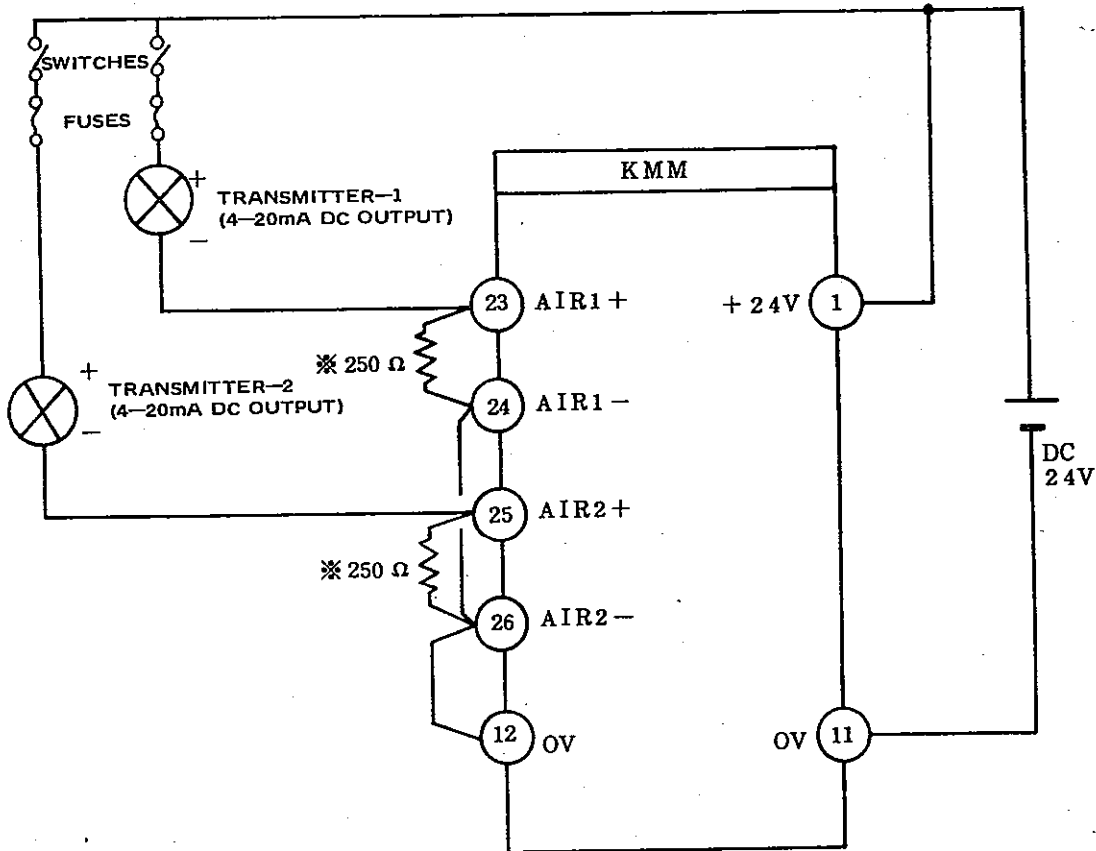

Figure 4.4 Connections Between KMM and Instrument of Other Power Supply (AC system)

- (4) Connections between KMM and a Transmitter



\* Not required if the transmitter output is 1 to 5V DC.

Figure 4.5 Connections Between KMM and a Transmitter

### 4.3.2 Connections for Analog Output

#### ① Connections for current output

The current output is of a negative common type.

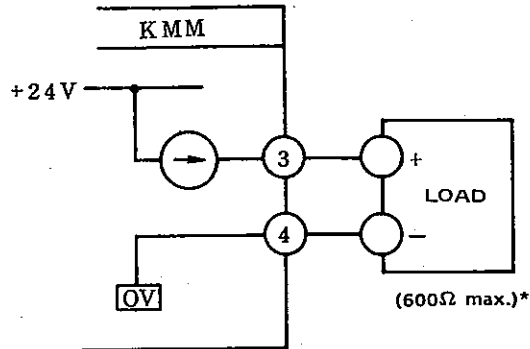

Negative common type (standard specification)

\* 500Ω maximum when standby manual is used.

Figure 4.6 Connections for Current Output

#### ② Connections for voltage outputs

The voltage outputs are differential signals, with a "+" (positive) and a "-" (negative) line for each output.

##### (1) Connections between DigitroniK Line Instruments

Refer to Figure 4.2 shown on a former page.

##### (2) Connection between KMM and instrument which has SC (connection for common power supply)

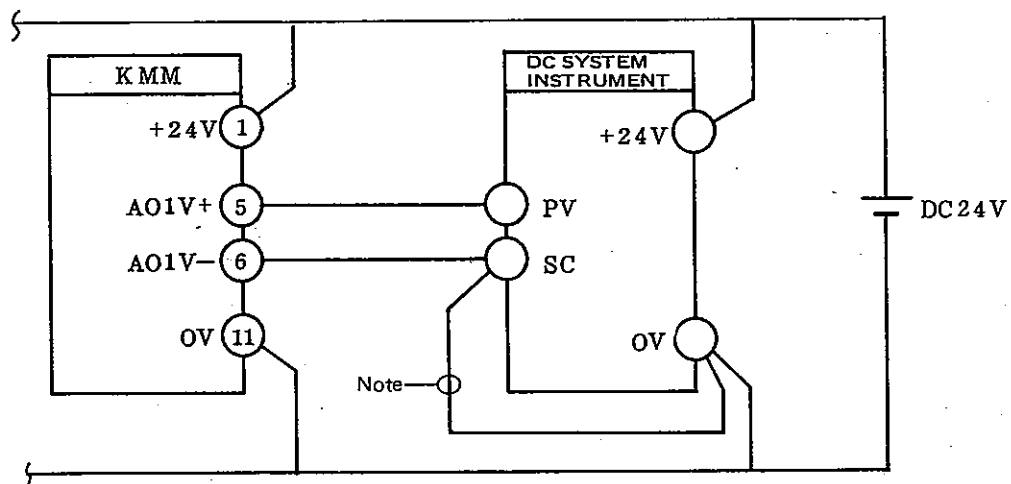

Note: Do not make this connection if the instrument has been connected at other point, in such case as a Wiring Block is used. When two or more instruments are connected, use only a single line for this connection.

Figure 4.7 Connections Between KMM and Instrument which has SC (Common Power Supply)

- (3) Connections between KMM and instrument which has SC (separate power supply)

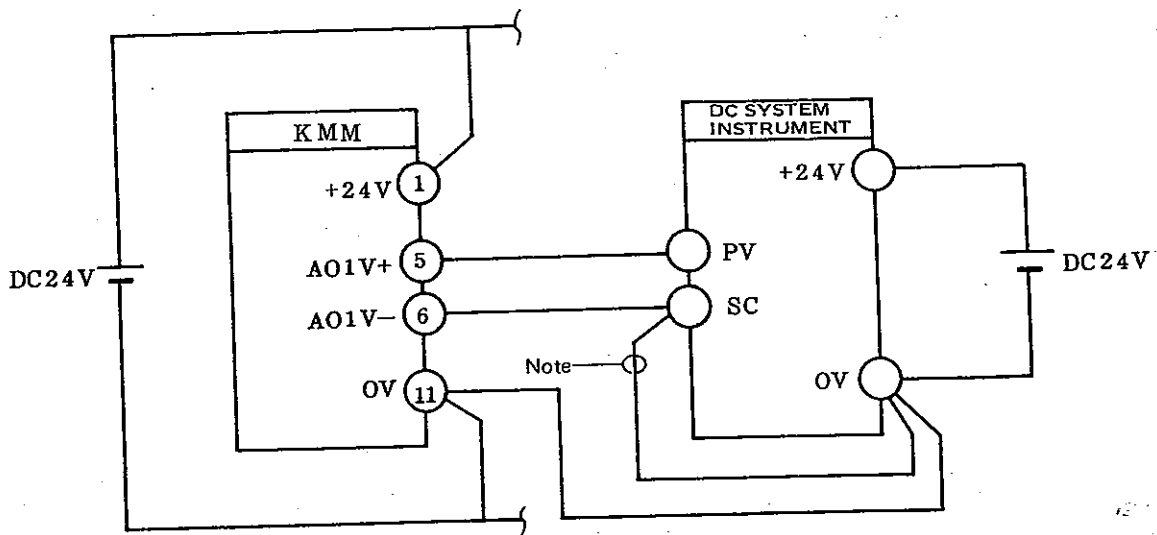

Note: The same as that of the case of (2).

Figure 4.8 Connections Between KMM and Instruments which has SC (Separate Power Supply)

- (4) Connections between KMM and an instrument of separate power supply (AC system)

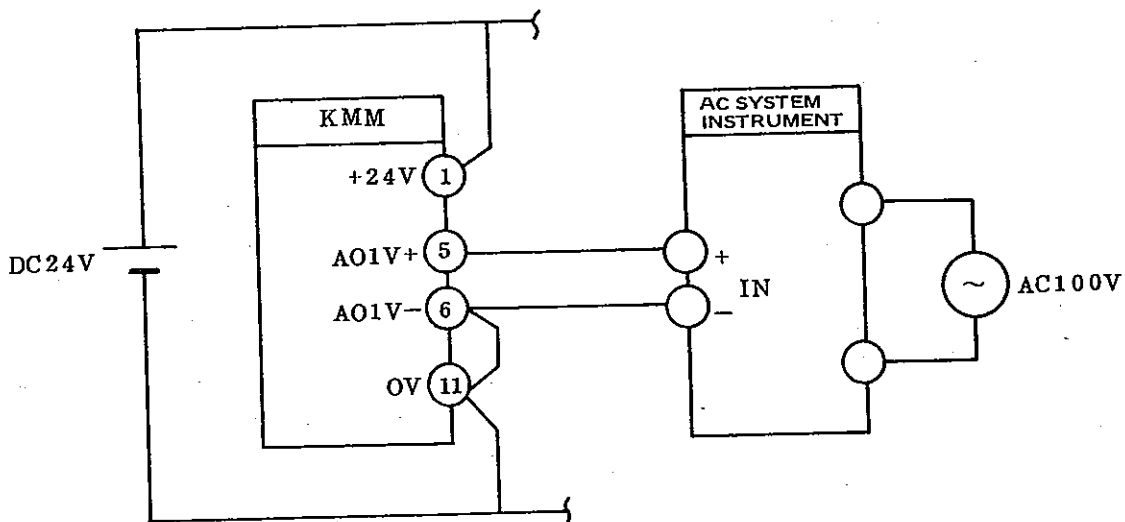

Figure 4.9 Connections between KMM and Instrument of Separate Power Supply (AC System)

- (5) Connections between KMM and an instrument which has no power supply

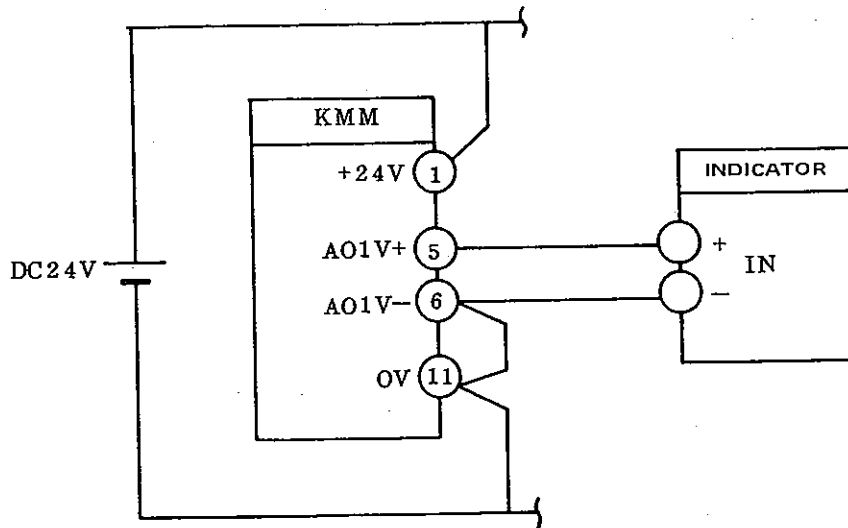

Figure 4.10 Connections between KMM and Instrument which has No Power Supply

#### 4.2.3 Digital Input

The digital input circuit is of a diode-isolated type (Figure 4.11) and accepts any of the following types of inputs.

- ① Voltageless contacts (relay contact, transistor switch input, etc.)
- ② Voltage inputs (semiconductor switch input, etc.)

#### Specifications for digital input

- o Input voltage:
  - LOW: 0 to 4V DC
  - HIGH: 10 to 30V DC
- o Input bias current:
  - LOW: -3 mA or less
  - HIGH: 10  $\mu$ A or less
- o Allowable input overvoltage: 30V DC

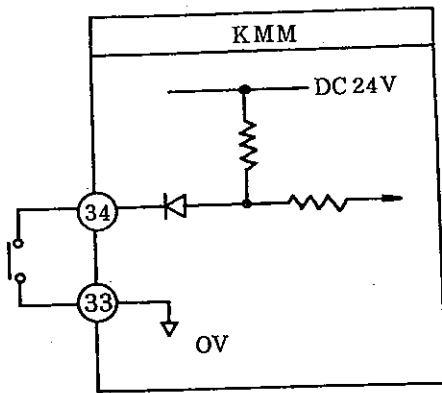

(a) Relay contact

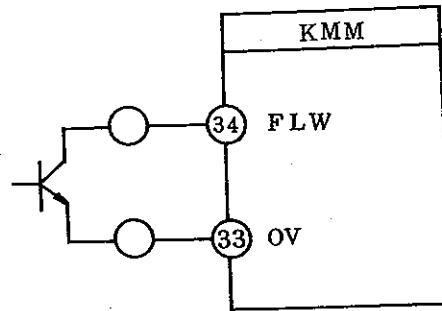

(b) Transistor switch input

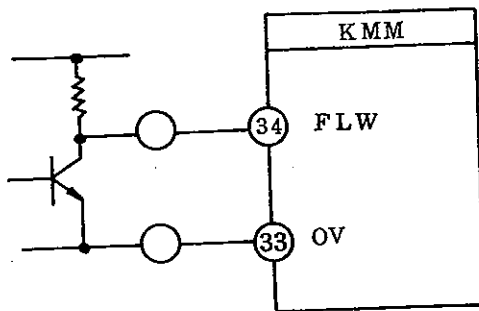

(c) Voltage input (semiconductor switch input)

Figure 4.11 Connection Methods for Digital Input

#### 4.3.4 Digital Output

The digital output circuit is of an open-collector transistor contact type.

- o Contact rating: 30V DC, 0.1A (resistance load)
- o Protective function: When the load current has become larger than 0.2A DC, the digital output is automatically turned off to protect the output transistors.

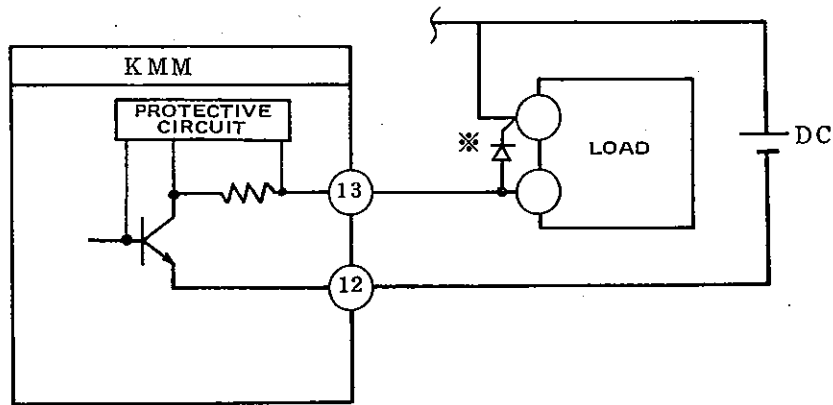

\* When an inductive load (such as relay) is used, provide a noise killer provision (such as connecting a diode in parallel to the load).

Figure 4.12 Connections for Digital Output

#### 4.3.5 Notes for Signal Connections

- ① The KMM performs self diagnosis with current output (A01) feedback. Therefore, when the current output signals is not required, connect terminals ③ and ② with a jumper wire.
- ② The KMM is locked when an external interlock signal is applied. When this interlock function is not required, short between terminals ③③ and ③⑦ with a jumper wire.
- ③ Ground the chassis (terminal ②① ) to an earth ground of JIS Class 3 (grounding resistance 100 ohms or less) or better.

#### 4.3.6 Rear Terminals and Signals

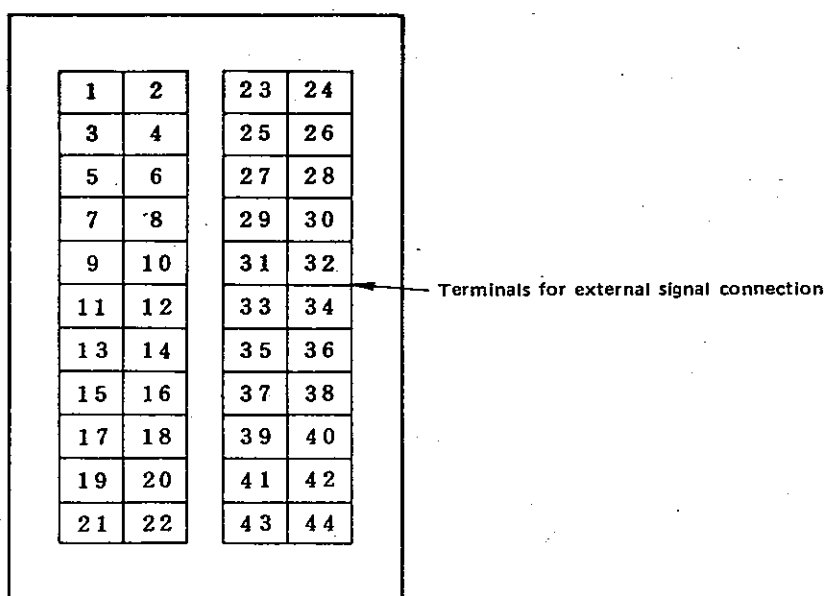

Figure 4.13 Rear Terminal Block

Table 4.1 Terminal Numbers and Corresponding Signals

| Terminal No. | Symbol   | Description                     |
|--------------|----------|---------------------------------|
| 1            | +24V     | Instrument main power ⊕         |
| 2            | SM + 24V | Standby manual unit power ⊕     |
| 3            | A01I +   | 4 to 20 mA current output ⊕     |
| 4            | A01I -   | 4 to 20 mA current output ⊖     |
| 5            | A01V +   | 1 to 5V voltage output ⊕        |
| 6            | A01V -   | 1 to 5V voltage output ⊖        |
| 7            | A02 +    | 1 to 5V voltage output ⊕        |
| 8            | A02 -    | 1 to 5V voltage output ⊖        |
| 9            | A03 +    | 1 to 5V voltage output ⊕        |
| 10           | A03 -    | 1 to 5V voltage output ⊖        |
| 11           | 0V       | Power ⊖<br>DO1 to DO3, S common |
| 12           | 0V       |                                 |
| 13           | DO2      | Digital output 2                |
| 14           | DO3      | Digital output 3                |
| 15           | DO1      | Digital output 1                |
| 16           | S        | Standby mode (Note 1)           |
| 17           | SM PV+   | PV ⊕ for standby manual unit    |
| 18           | SM PV-   | PV ⊖ for standby manual unit    |
| 19           | --       | Unused                          |
| 20           | --       | Unused                          |
| 21           | GND      | Chassis ground                  |
| 22           | GND      | Chassis ground                  |
| 23           | AIR1+    | 1 to 5V voltage input ⊕         |
| 24           | AIR1-    | 1 to 5V voltage input ⊖         |
| 25           | AIR2+    | 1 to 5V voltage input ⊕         |
| 26           | AIR2-    | 1 to 5V voltage input ⊖         |
| 27           | AIR3+    | 1 to 5V voltage input ⊕         |

| Terminal No. | Symbol | Description                              |
|--------------|--------|--|
| 28           | AIR3-  | 1 to 5V voltage input ⊖                  |
| 29           | AIR4+  | 1 to 5V voltage input ⊕                  |
| 30           | AIR4-  | 1 to 5V voltage input ⊖                  |
| 31           | AIR5+  | 1 to 5V voltage input ⊕                  |
| 32           | AIR5-  | 1 to 5V voltage input ⊖                  |
| 33           | 0V     | INT'K, DI1 to DI4 common                 |
| 34           | DI1    | Digital input 1                          |
| 35           | DI2    | Digital input 2                          |
| 36           | DI3    | Digital input 3                          |
| 37           | INT'K  | External interlock signal input (Note 2) |
| 38           | DI4    | Digital input 4                          |
| 39           | LINK + | C-LINK ⊕                                 |
| 40           | --     | Unused                                   |
| 41           | LINK - | C-LINK ⊖                                 |
| 42           | --     | Unused                                   |
| 43           | --     | Unused                                   |
| 44           | --     | Unused                                   |

- Notes:
1. When in standby mode, output is OFF. (When in normal mode, output is ON.)
  2. External interlock when input is OFF.
  3. Never use the "Unused" terminals.

#### 4.4 Grounding

To ground the KMM, use either one of the following two methods, paying attention to avoid multiple-point grounding.

- ① To ground the logic common (0 V) and chassis (GND)

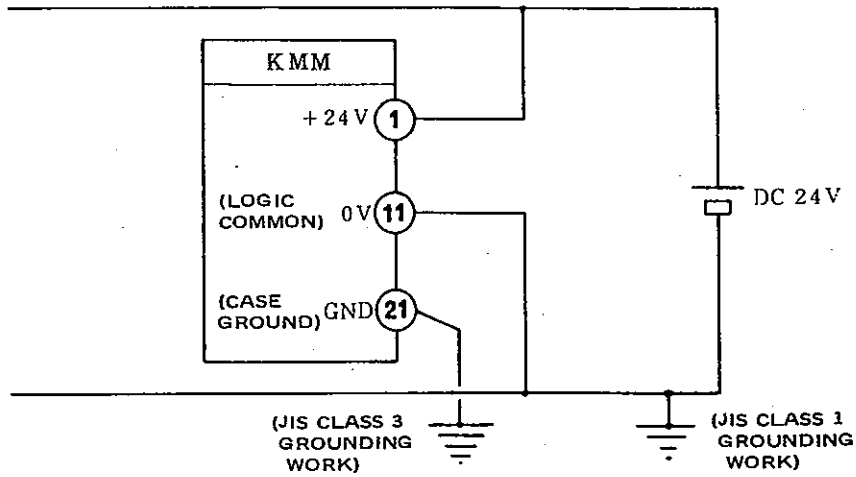

- ② To ground the chassis alone

Provide this grounding only when it is impracticable to ground the logic common

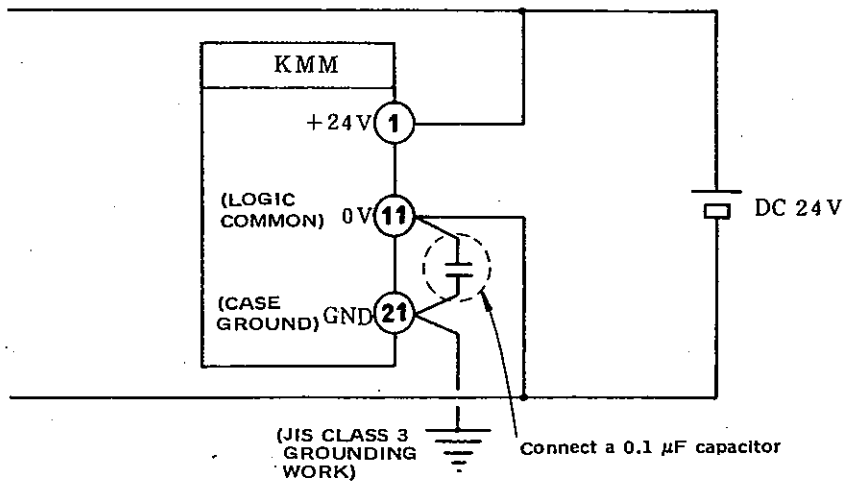

## 5. COMMUNICATIONS FUNCTIONS (OPTIONS)

By incorporating communications functions, the KMM can be linked to an equipment of an upper hierarchy.

### 5.1 Types of Communications

To connect to the KMM, the type of communications must be specified.

- 0: Without communications
- 1: With communications (without SPC DDC)
- 2: With communications (with SPC DDC)

### 5.2 Specifying Method of Type of Communications

Select the required type of communications with the auxiliary switches on the side panel. For the controller which is connected to the communications system, set a station number for each unit of controller.

### 5.3 Types of Communications and Types of Controllers

| Type of controller \ Type of communications | 0 | 1 | 2 | 3 |
|---|---|---|---|---|
| 0   | 0 | 0 | 0 | 0 |
| 1   | 0 | 0 | 0 | 0 |
| 2   | 0 | 0 | X | 0 |

0: Available

X: Unavailable

### 5.4 Computer Mode

When operating in the SPC DDC mode with computer by specifying Communications Type 2, the KMM is capable of a computer mode and a request mode in additions to regular modes of operation.

#### 5.4.1 Turning into Computer Mode

- ① Turning from the manual mode or auto mode

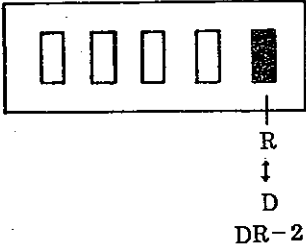
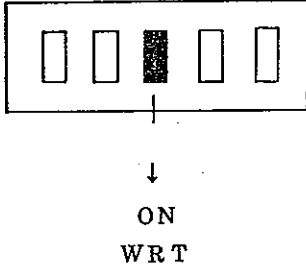
| Step No. | Procedure  | Remarks  |
|----------|--|--|
| 1        | <p>Set the D/R2 auxiliary switch on side panel to the R state.</p>  |  |
| 2        | <p>Turn ON the WRITE auxiliary switch.</p>                         | <p>Communications link with upper hierarchy equipment is enabled.</p>  |
| 3        | <p>Press the <b>C</b> button on the instrument front panel.</p>  | <p>A computer mode request is sent to the computer. This state is called "request mode" and both the <b>C</b> lamp on the instrument front panel and the current mode lamp (<b>A</b> or <b>M</b>) turn on.</p> <p style="text-align: center;">↓</p> <p>The computer accepts the request and turns the controller into the computer mode. It sends a command.</p> <p style="text-align: center;">↓</p> <p>As the controller received the command, it becomes the computer mode and the mode lamp (<b>A</b> or <b>M</b>) which has there-to been lighted goes off.</p> |

- o There are two types of commands for turning the instrument into the computer mode: One is COMP-AUTO (SPC) and the other is COM-MAN (DDC). The computer selects either SPC or DDC. (In either case, the **C** lamp turns on.)
- o To know whether the computer mode of operation is with SPC or DDC, press the DISP CHG button on the side panel of the instrument. If in the SPC mode, the **A** lamp will light in addition to the **C** lamp. If in the DDC mode, the **M** lamp will light.
- o When in the SPC mode, the controller performs its PID operation as its setpoint the CSP (computer SP) received from the computer. In this case, the LSP (local SP) follows the CSP.
- o When in the DDC mode, the COUT (computer OUT) received from the computer is used as the output of the PID arithmetic unit of the controller.

② Turning from the cascade mode

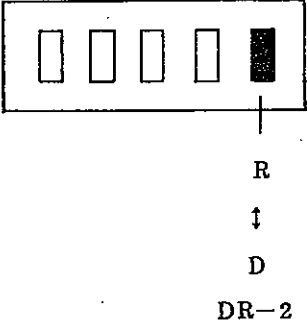
|   | Procedure  | Remarks   |
|---|--|---|
| 1 | Set the D/R2 auxiliary switch to the R state.<br><br> | The controller is transferred to a preselected backup mode (auto mode or manual mode). Specify the backup mode when generating the User PROM. |
| 2 | The further procedures are identical with those of ① Turning from the manual mode or auto mode.  |   |

#### 5.4.2 Operations When in Computer Mode

- o When in a computer mode of operation, switching between the COMP-AUTO (SPC) mode and the COMP-MAN (DDC) mode is made as commanded by the computer.
- o If a computer failure (TOG\* time out) is caused when in a computer mode of operation, the controller is transferred to a preselected backup mode (AUTO or MAN). \*Time Out Gate
- o If the FOLLOW mode is requested with an external contact signal when the controller is in a computer mode of operation, the controller is transferred to the FOLLOW operation (the **A** or **M** lamp blinks) of backup mode (AUTO or MAN). When the FOLLOW mode request signal is released, the controller returns to the backup mode ( **A** or **M** ) lamp stops blinking).
- o If the D/R2 auxiliary switch on the side panel is thrown to the D position when in a computer mode of operation, the controller is transferred to the backup mode.
- o To transfer from a computer mode to other mode, press the required mode button (the **A** or **M** button).

#### 5.4.3 Operations When in Request Mode

- o If the COMP-AUTO (SPC) or COMP-MAN (DDC) command is received from the computer when in the request mode, the controller is transferred into the computer mode.
- o If the AUTO, MAN, FOLLOW, IM, or S mode is commanded when in the request mode, the request mode is released.

### 5.5 Data Which Can be Changed From Communications System

| Equipment of upper hierarchy |           | Local operator station<br>Operator station<br>(Communication Type 1)                         | Computer<br>(Communication Type 2)                                      |
|------------------------------|-----------|--|---|
| Mode                         |           |  |   |
| COMP mode                    | COMP-AUTO | Control constant<br>Mode (AUTO, MAN)   | CSP<br>Control constant<br>Mode (COMP-M, AUTO, MAN)                     |
|                              | COMP-MAN  | LSP1<br>Control constant<br>Mode (AUTO, MAN)   | COU<br>Control constant<br>Mode (COMP-A, AUTO, MAN)                     |
| CAS                          |           | LSP1 * <sup>4</sup><br>Control constant<br>Mode (AUTO, MAN)                                  | Control constant<br>Mode (AUTO, MAN)                                    |
| AUTO                         |           | LSP1 LSP2<br>Control constant<br>Mode (CAS* <sup>1</sup> , MAN, REQ* <sup>2</sup> )          | Control constant<br>Mode (CAS* <sup>1</sup> , MAN, REQ* <sup>2</sup> )  |
| MAN                          |           | LSP1, LSP2<br>OUT<br>Control constant<br>Mode (CAS* <sup>1</sup> , AUTO, REQ* <sup>2</sup> ) | Control constant<br>Mode (CAS* <sup>1</sup> , AUTO, REQ* <sup>2</sup> ) |
| IM                           |           | LSP1, LSP2<br>OUT<br>Control constant<br>Mode (MAN* <sup>3</sup> )                           | Control constant<br>Mode (MAN* <sup>3</sup> )                           |
| FOLLOW                       |           | LSP1, LSP2<br>Control constant   | Control constant  |
| REQ                          |           | LSP1, LSP2<br>Control constant<br>Mode (AUTO, MAN)   | Control constant<br>Mode (COMP-A, COMP-M, AUTO, MAN)                    |

REQ: Request mode

\*1: Possible if auxiliary switch (D/R2) of controller is set in the D position.

\*2: Possible if the D/R2 is set in the R position.

\*3: Possible by pressing the  (R) (RST) button or by sending the reset command.

\*4: For Controller Type 3 only.

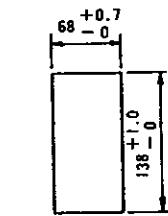
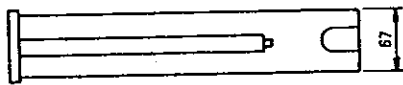
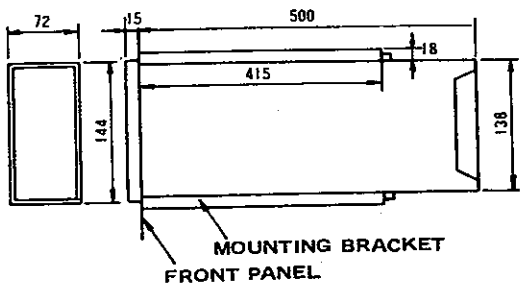

Single unit Installation

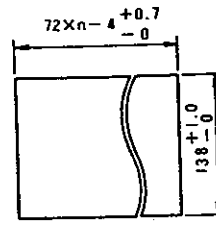

Multiple units (n-number)  
Installation

Panel cutout dimensions

Installation Dimensions