

Yamatake

Digital Process Reporter Intelligent Hybrid Recorder DPR500

User's Manual

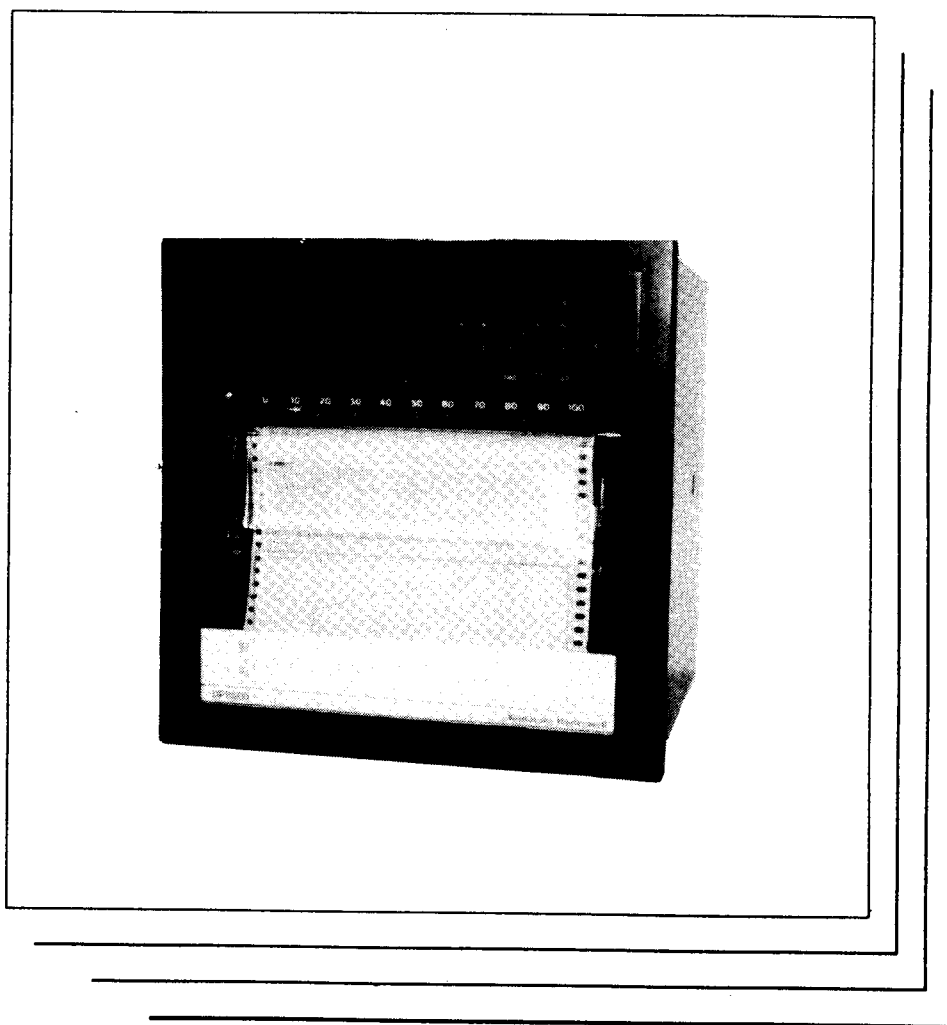

Thank you for your purchase of [Digital Process Reporter DPR500].

This User's Manual intends to enable you to know an outline of the DPR500 and learn its installation, connections, setting, and operation. You are, therefore, requested to read this User's Manual without fail before using DPR500.

If any question has arisen, please contact your nearest Yamatake-Honeywell's business office or sales agent.

No part of this manual can be copied or reproduced in any form without permission. For the contents of this manual, alteration is reserved without notice in the future.

Request:

Keep this User's Manual ready to the operator in charge.

CONTENTS

	<u>Page</u>
Chapter 1 CONFIRMATION OF PRODUCT AND ATTACHMENTS & REMOVAL OF FIXING SCREWS FOR TRANSPORTATION	1
1-1 Confirmation of Product Model No.	1
1-2 Confirmation of Attachments	1
1-3 Removal of Transportation Lock Screws	1
Chapter 2 PRODUCT SPECIFICATIONS	2
Chapter 3 NAMES AND FUNCTIONS OF COMPONENT PARTS	7
3-1 Entire Configurtaion	7
3-2 Configuration of Component Parts	8
Chapter 4 INSTALLATION	10
4-1 Mounting Place	10
4-2 Mounting Method	10
4-3 Mounting Dimensions and Panel Cutout Size	10
Chapter 5 CONNECTIONS	11
5-1 Cautions on Connections	11
5-2 Input/Output Signals	11
5-3 Grounding	12
5-4 Instrument Power Supply	12
5-5 Noise Generation Sources and Reduction Measures	12
5-6 Use of Round Crimp Style Terminals	12
5-7 Terminal Connection Diagram	13
Chapter 6 PREPARATION FOR OPERATION	14
6-1 Confirmation of Recording Stop	14
6-2 Loading of Chart	14
6-3 Mounting of Ink Ribbon Cassette	18
6-4 Mounting of Pen Cartridge	19
6-5 Mounting of Dry Batteries for Backing Up the Clock	21
6-6 Mounting of Power Fuse	22
6-7 POWER Switch and RCD (Recordng ON/OFF) Key	22

	<u>Page</u>
Chapter 7 SETTING (CONFIGURATION) BEFORE STARTING OPERATION ...	23
7-1 Display Arrangement in Configuration Mode	23
7-2 Configuration Setting Codes Table	24
7-3 Setting Procedure Table	25
7-4 Common Key Operation	26
7-5 Input Range Setting	27
7-6 Recording Scale Setting	37
7-7 Event Setting	45
7-8 Tag Name Setting	48
7-9 Engineering Unit Setting	51
7-10 Selection of Recording Formats and Phase Synchronizing Method	54
7-11 Chart Speed Selection	56
7-12 Keylock Levels and Communication Conditions Setting	58
7-13 Setting of Date (Year, Month, and Day)	61
7-14 Setting of Time	62
Chapter 8 OPERATION	63
8-1 Turning on the Power Supply	63
8-2 Pen Lifter Operation	63
8-3 Recording Start/Stop	63
8-4 Forward Feed and Backward Feed of Chart	63
8-5 List Printing	64
8-6 Demand Printing	64
8-7 User Message Printing	64
8-8 Display Selection	65
8-9 Event Occurrence Display	65
8-10 Keylock	66
8-11 "CAL" Key Mode	66
8-12 Operation of Wire Dot Printer during Recording	66
8-13 Chart Speed-to-Printing Relation	66
Chapter 9 TROUBLESHOOTING	67
9-1 Neither Display nor Recording is Done.	67
9-2 Abnormal Display	67
9-3 The Indicator Indicates Data correctly, but Data are not Recorded correctly.	68
9-4 Self-diagnosis and Error Codes Table	69
Chapter 10 MAINTENANCE	70
10-1 Consumables	70

Chapter 1 CONFIRMATION OF PRODUCT AND ATTACHMENTS & REMOVAL OF FIXING SCREWS FOR TRANSPORTATION

1-1 Confirmation of Product Model No.

The following table shows the model number configuration of this product. Check if your instrument model number is correct as ordered.

Model Number Table I II III IV V VI VII VIII Ex. : DPR502A11111X

I	II	III	IV	V	VI	VII	VIII	Contents
Basic model number	Indication unit	Power voltage	External contact input	Event output	Chart illuminating lamp	Communication function	Additional processing	
DPR501								1-pen recorder
DPR502								2-pen recorder
	A							°C
	B							°F
		1						100V AC, 50/60Hz
		2						115V AC, 50/60Hz
		3						200V AC, 50/60Hz
		4						230V AC, 50/60Hz
			0					None
			1					3 points
				0				None
				1				6 points
					0			None
					1			Provided
						0		None
						1		Communication standard RS-232C
						2		Communication standard RS-485
							X	None
							D	With test data
							T	Tropical treatment
							S	With test data and tropical treatment

1-2 Confirmation of Attachments

After unpacking packages, check if the following attachments are contained.

Article Name	Part No.	Q'ty
• Fan-fold chart		1 pad
• 1-pen cartridge (red)	(Attached to DPR501/1-pen model) 80340571-001	1 pc.
• 1, 2-pen cartridge (red, green)	(Attached to DPR502/2-pen model) 80340571-003	1 each
• Ink ribbon cassette (black)	80340580-001	1 pc.
• 100V AC fuse (1A)	83957011-001	1 pc.
• 200V AC fuse (0.5A)	83957011-008	1 pc.
• SUM-3 dry battery		3 pcs.
• Mounting tools	80340458-001	1 set
• Engineering unit seal		1 sheet
• User's Manual	CP-UM-1500E	1 copy

1-3 Removal of Transportation Lock Screws

The case and chassis are fixed to each other by transportation lock screws for the purpose of preventing them from being broken during transportation. Remove these screws before using this system.

Mount these screws in advance, if the system is transported again.

Chapter 2 PRODUCT SPECIFICATIONS

Input	Input type	DC voltage, thermocouple, resistance thermometer bulb. See Table 1 (input types, ranges, indication accuracies).	
		Note: DC current is converted to 1 to 5V DC through an externally mounted precision resistor (Model No. J-ARR50 or 81401325: option).	
	Number of input channels	1 or 2	
	Input scan interval	125ms. (250ms once every approx. 1sec)	
	Input impedance	DC voltage (mV) and thermocouple inputs: 10MΩ or more	
		DC voltage (V): approx. 1MΩ or more	
	Wiring resistance	DC voltage (mV, V), thermocouple input: 2kΩ or less	
		Resistance thermocouple bulb input: 10Ω or less each (3 wires of identical resistance)	
	Reference point compensation	±0.5°C when the input is other than the following:	
		±1.0°C when K, E, J, T of -100°C or less, KP vs Au7Fe of -250°C or less, L of -50°C or less, or U of 0°C or less as thermocouple input.	
	Burnout	Select upscale, downscale or off for each input channel in the case of thermocouple input.	
	Input bias current	±100nA without burnout, or ±200nA with burnout when thermocouple input is applied.	
	Measuring current	Approx. 1mA when resistance thermometer bulb input is used.	
	PV bias	Settable for each input channel within the range of -19999 to 29999.	
Linear scaling	Indication and recording in EU (engineering unit) are available for DC voltage (mV, V) inputs.		
Measuring and calculating methods	<ul style="list-style-type: none"> • PV • Deviations between channels • Deviation from setpoint • Square root extraction (set dropout values) 		
Measuring range	DC voltage (mV, V) input: Any measuring range (higher and lower-limit values) is available within the input range.		
Engineering range	DC voltage (mV, V) input: The engineering range (higher and lower-limit values, unit, decimal point) can be set within the measuring range of -19999 to 29999.		
Record scale	Any record scale can be set for each channel within the range of -19999 to 29999.		
Indication	Digital indication	Indication method	8 digits, 7-segment LED (red) and unit LEDs (red, 3 pcs)
		Indication interval	4 sec
		Details of indication	<ul style="list-style-type: none"> • PV • Channel No. • Alarm indication • Year, month, day • Hour, minute • Chart feed speed • Other configuration data
	Lamp indication	Details of indication	<ul style="list-style-type: none"> • Lights during record or event occurrence • Lights to show details in configuration or operation mode.
Reporting	Recording	Pen recording	Pen 1 (red): Input channel 1, Pen 2 (green): Input channel 2
		Digital recording	Dot matrix; ink ribbon (black)
		Pen speed	Within 2.8 sec (time required to reach recording accuracy with respect to the step input of 0 to 90%)
		Character configuration	7 dots (height) × 5 dots (width) matrix, 9 digits (max.)
		Record format	<ul style="list-style-type: none"> • Trend record (zone record available). • Trend + Tabular record • Tabular record • List printing
		Printing restriction (common to all record formats)	<p>All designated print specifications are executed when the chart feed speed is 1500mm/h or less.</p> <p>Only the time marker is printed when the chart feed speed is 3000mm/h or more.</p>
		Phase synchronization	<p>Pen 1 data is temporarily stored in RAM, and then is recorded simultaneously with pen 2 data. However, there are the following storage restrictions exist:</p> <p>When the chart speed is 12.5mm/h or more, the input is stored as it is.</p> <p>When the chart speed is 10mm/h, the average value of twice input data at measuring interval of 125ms is stored.</p> <p>When the chart speed is 5mm/h, the average value of three times input data at measuring intervals of 125ms is stored.</p>

Reporting	Chart	Shape	Continuous folding sheet			
		Effective width	180mm			
		Total length	20m			
		Completion notice	1.5m before chart completion			
		Chart feed manner	Stepping motor and sprockets used			
		Chart speed	5, 10, 12.5, 25, 50, 75, 100, 150, 300, 600, 750, 1500, 3000, 4500, 6000, 9000mm/h (settable)			
	Recording accuracy	Direction of PV axis	(The indication accuracy given in Table 1) + ($\pm 0.5\%$ of record full scale, however, $\pm 1\%$ in case of zone record)			
Direction of time axis		$\pm 0.5\text{mm}$				
[Reference]		Chart stretch/shrinkage: About $+0.7\%$ FS stretched when the ambient humidity reaches 85%RH (from 60%RH) About -0.2% FS shrunk when the ambient humidity reaches 45%RH (from 60%RH).				
Record format	Trend record	<ul style="list-style-type: none"> Analog PV Tag No. (only when the record scale is set) Year, month, day, hour, minute Time marker Chart feed speed Record scale (0% and 100% values only) EU (only when the record scale is set) Event status (Channel No., occurrence/return time, event No. and states are printed) Chart speed changeover time, and speed value after change ON/OFF of phase synchronization (when phase synchronization is ON, POC ON is printed during time printing or chart speed printing. When it is OFF, nothing is printed.) 				
		Printing intervals	Year, month, day 00:00 12:00 Printed at these positions	Hour, minute 00:00 at 150mm intervals as standard	Time marker 00:00 at 75mm intervals as standard	Chart speed At 150mm intervals as standard, 75mm after hour and minute.
	Tabular record	The following details are recorded by the tabular report command (demand record): • Year, month, day • Hour, minute • Channel No. • Event status • PV • Engineering unit				
	Trend record + Tabular record	<ul style="list-style-type: none"> Digital values are recorded simultaneously by the trend report after range is printed. All trend format items are printed. All tabular format items are printed. Printing intervals: PV is printed at 75mm intervals with 00:00 as standard. 				
	Zone split record (valid only in two-pen type)	The chart can be split into two zones of 90mm individual span for each channel				
		Items printed irrespective of zone	<ul style="list-style-type: none"> Year, month, day Hour, minute Chart feed speed Chart speed changeover time Phase synchronization ON/OFF 			
		Items printed for each zone	<ul style="list-style-type: none"> Analog PV Channel No. Engineering unit Record scale Event status 			
	Printing intervals	Year, month, day 00:00 12:00 Printed at these positions	Hour, minute 00:00 at 150mm intervals as standard	Time marker 00:00 at 75mm intervals as standard	Chart speed At 150mm intervals as standard, 75mm after hour and minute.	Scale, Tag No., and engineering unit Those of CH.1 and CH. 2 are printed alternately near the time marker at 75mm intervals (CH.1 only for Pen 1).
List printing	Full list printing: All parameters preset for configuration are printed. Partial list printing: Only the frequently used parameters such as event set value are printed.					
Events	Setting	Number of setpoints	4 for each channel			
		Setting range	-19999 to +29999 (decimal point location depends upon the range)			
		Actuation clearance	0 to 29999 (decimal point location depends upon the range)			
	Actuation	Upper alarm	Actuates when PV/deviation exceeds the upper event setpoint.			
		Lower alarm	Actuates when PV/deviation goes below the lower event setpoint.			
	Output mode	Record	• Channel No. • Event occurrence/return time and state • Event level			
Indication		• Event level and measured value at event occurrence • Other channel's event occurrence/return state				
Event output		None (event output is optionally selected)				

Options	External contact inputs	Number of inputs	3 points		
		Functions	The following remote operations are performed via the external contact inputs <ul style="list-style-type: none"> • Record start/stop • Record scale and chart feed speed changeover • Tabular record Note: Contacts hold ON/OFF state for 500ms or more before operation to prevent malfunctioning due to noise.		
		Input scan interval	100ms		
		Switch type	Alternate		
		Input terminal open-circuit voltage	Approx. 6V		
		Input terminal short-circuit current	Approx. 5mA		
	Event outputs	Monitoring	125ms (250ms once every second)		
		Number of outputs	6 points		
		Output action	Event outputs assigned to each output relay for each channel (OR operable)		
		Relay action	Direct (the output relay is operated when the event is ON)		
		Output manner	Transfer contact output		
		Contact rating	240V AC 1A (nonconductive load), 30V DC 1A (nonconductive load)		
	Chart illuminating lamp	Cold cathode fluorescent lamp			
	Communications	Communication standard	Standard	RS-232C	RS-485
			Number of signal lines	8 (including FG)	5
			Transmission distance	15m or less	500m or less
		Protocol	Standard	Conforms to YH CP-system protocol	Conforms to YH CP-system protocol
			Network	1 to 1	Multidrop (max. 31 slaves)
			Function	Slave	Slave
			Master station	Not specified	Not specified
Transmission		Synchronizing method	Start-stop synchronization	Start-stop synchronization	
		Communication method	Half duplex	Half duplex	
		Transmission rate	1200, 2400, 4800, 9600BPS	1200, 2400, 4800, 9600BPS	
		Start bits	1	1	
		Data length	7, 8	7, 8	
		Parity	Even or none	Even or none	
		Stop bits	1, 2	1, 2	
Error check	Vertical parity check, sum check	Vertical parity check, sum check			
General	Memory protection	Preset data	EEPROM		
		Clock backup	Three dry cells (small size; to be replaced after about one year's service)		
	Vibration resistance	0 to 0.1m/s ² (0 to 100Hz)			
	Insulation resistance	20MΩ or more (between each terminal and GND terminal under 500V DC) Not specified for the external contact input terminals			
	Dielectric strength	Dielectric strength of input	Leak current 2mA or less Between the measuring input terminal and GND terminal: 1 min duration under 1500V AC (50/60Hz) Between the measuring input terminals: 1 min duration under 140V AC (50/60Hz) Between the communication terminal and GND terminal: 1 min duration under 100V AC (50/60Hz) Between the external contact input terminal and GND terminal (Note 3): 1 min duration under 15V AC (50/60Hz) Note: Since each external contact input terminal is connected to the GND terminal via a zener diode of approx. 30V, it cannot be used in circuits where a common mode voltage is applied between the external contact input terminal and GND terminal.		
		Dielectric strength of power supply and event output	Leak current 5mA or less Between the power terminal and GND terminal: 1 min duration under 1500V AC (50/60Hz) Between the event output terminal and GND terminal: 1 min duration under 1500V AC (50/60Hz)		

General	Conduction resistance	Common mode rejection ratio	120dB					
		Normal mode rejection ratio	40dB					
	Environmental conditions	Ambient temperature range	0 to 50°C					
		Ambient humidity range	30 to 90%RH (non-condensing)					
	Transport / storage conditions	Ambient temperature for storage	-40 to +70°C (pen cartridge: -20 to +50°C)					
		Ambient humidity for storage	5 to 95%RH (non-condensing)					
		Impact resistant	0 to 30m/s ²					
	Rated power supply	100V AC, 115V AC, 200V AC, 230V AC, 50/60Hz (optional)						
	Tolerable variation in power supply	±10% of rated value						
	Power consumption	Approx. 35V						
	Materials	Case: Steel (bonderizing steel plate)		Door frame: Glass fiber-reinforced polyester resin				
		Door window: Glass						
	Coating colors	Case: Black	Door frame: Black	Door window: Transparent				
Weight	Approx. 14.1kg (without options), Approx. 14.4kg (with options)							
Mounting	Flush							
Installation angle	Up to 30 degrees, downward from back to front							
Standard accessories	Name	Part No.	Q'ty	Consumables (separately order)	Name	Part No.	Minimum unit	
	Continuous paper	80340408-001	1 set		Continuous paper	80340408-001	10 sets	
	Pen 1 cartridge (red) *1	80340571-001	1 pc		Pen 1 cartridge (red)	80340571-001	4 pcs	
	Pen 1, 2 cartridges (red, green) *2	80340571-003	1 pc, each		Pen 2 cartridge (green)	80340571-002	4 pcs	
	Ink ribbon cassette (black)	80340580-001	1 pc		Pen-1, 2 cartridges (red, green)	80340571-003	4 sets	
	Fuse 1A (100V AC system)	83957011-001	1 pc		Ink ribbon cassette (black)	80340580-001	1 pc	
	Fuse 0.5A (200V AC system)	83957011-008	1 pc		Fuse, 1A (100V AC system)	83957011-001	10 pcs	
	Dry cell (small size) battery	—	3 pcs		Fuse, 0.5A (200V AC system)	83957011-008	10 pcs	
	Mounting bracket	80340458-001	1 set		Chart illuminating lamp	80340242-001	1 pc	
	Engineering unit seal	—	1		Auxiliaries (separately order)	Precision resistor (accuracy ±0.02%) *3	81401325	1 pc
	Instruction Manual	—	—			Precision resistor (accuracy ±0.05%) *3	J-ARR50 (6 pcs)	1 set
	Notes: *1: Comes with DPR 501. *2: Comes with DPR 502.			RS-232C cross cable		CBL-RS232T02	2 m	
				RS-232C cross cable		CBL-RS232T08	8 m	
	Notes: *1: Comes with DPR 501. *2: Comes with DPR 502.			Note: *3 To convert 4 to 20mA DC into 1 to 5V Resistance 250Ω				

Input Types, Ranges, and Indication Accuracies

Input		Range		Indication accuracy (rdg means absolute value of indicated value)		Resolution		
Type	Symbol	Code	mV, V input	mV, V indication range				
DC voltage	mV	00	± 20mV	± 20.00	±(0.1% of rdg + 1 digit)		10µV	
		01	± 40mV	± 40.00	±(0.1% of rdg + 1 digit)		10µV	
		02	± 60mV	± 60.00	±(0.1% of rdg + 1 digit)		10µV	
		03	± 200mV	± 200.00	±(0.1% of rdg + 1 digit)		100µV	
	V	04	± 2V	±2000	±(0.1% of rdg + 1 digit)		1mV	
		05	± 6V	±6000	±(0.1% of rdg + 1 digit)		1mV	
		06	± 20V	±2000	±(0.1% of rdg + 1 digit)		10mV	
07		± 50V	±5000	±(0.1% of rdg + 1 digit)		10mV		
					The DC voltages (mV, V) given mean the values indicated before scaling.			
Type	Symbol	Code	Indication in °C	Indication in °F	Indication in °C ±	Indication in °F	Indication in °C	Indication in °F
Thermocouple (excluding reference point compensation)	R	10	0.0 to 1760.0	32 to 3200	0 to 100: ±3.7	32 to 212: ±8	0.2	1
					100 to 300: ±1.5	212 to 572: ±4	0.2	1
					More than 300: ±(0.15% of rdg+1.0)	More than 572: ±(0.15% of rdg+3)	0.2	1
	S	10	0.0 to 1760.0	32 to 3200	0 to 100: ±3.7	32 to 212: ±8	0.2	1
					100 to 300: ±1.5	212 to 572: ±4	0.2	1
					More than 300: ±(0.15% of rdg+1.0)	More than 572: ±(0.15% of rdg+3)	0.2	1
	B	12	400.0 to 1820.0	752 to 3308	400 to 600: ±3	752 to 1112: ±6	0.3	2
					More than 600: ±(0.15% of rdg+1.0)	More than 1112: ±(0.15% of rdg+3)	0.2	1
	K	13	-200.0 to +1370.0	-328 to +2498	-200 to -100: ±(0.15% of rdg+1.5)	-328 to -148: ±(0.15% of rdg+4)	0.2	1
					More than -100: ±(0.15% of rdg+0.9)	More than -148: ±(0.15% of rdg+3)	0.2	1
	E	13	-200.0 to +800.0	-328 to +1472	-200 to -100: ±(0.15% of rdg+1.0)	-328 to -148: ±(0.15% of rdg+3)	0.2	1
					More than -100: ±(0.15% of rdg+0.6)	More than -148: ±(0.15% of rdg+2)	0.2	1
	J	15	-200.0 to +1100.0	-328 to +2012	-200 to -100: ±(0.15% of rdg+1.1)	-328 to -148: ±(0.15% of rdg+3)	0.2	1
					More than -100: ±(0.15% of rdg+0.7)	More than -148: ±(0.15% of rdg+2)	0.2	1
	T	16	-200.0 to +400.0	-328 to +752	-200 to -100: ±(0.15% of rdg+1.0)	-328 to -148: ±(0.15% of rdg+3)	0.2	1
					More than -100: ±(0.15% of rdg+0.6)	More than -148: ±(0.15% of rdg+2)	0.2	1
	Ni-Ni+Mo	17	0.0 to 1200.0	32 to 2192	Full range: ±(0.15% of rdg+0.7)	Full range: ±(0.15% of rdg+2)	0.2	1
	WRe 0-26	18	0.0 to 2320.0	32 to 4208	0 to 300: ±(0.15% of rdg+1.0)	32 to 572: ±(0.15% of rdg+19)	1.1	3
					300 to 600: ±(0.15% of rdg+1.5)	572 to 1112: ±(0.15% of rdg+4)	0.2	1
					More than 600: ±(0.15% of rdg+1.0)	More than 1112: ±(0.15% of rdg+3)	0.2	1
	WRe 5-26	19	0.0 to 2320.0	32 to 4208	0 to 300: ±(0.15% of rdg+1.5)	32 to 572: ±(0.15% of rdg+4)	0.2	1
					More than 300: ±(0.15% of rdg+1.0)	More than 572: ±(0.15% of rdg+3)	0.2	1
	PR40-20	20	0.0 to 1880.0	32 to 3416	0 to 500: ±40	32 to 932: ±73	2.2	5
					500 to 900: ±12	932 to 1652: ±23	0.7	2
					900 to 1500: ±(0.3% of rdg+0.6)	1652 to 2732: ±(0.3% of rdg+12)	0.4	2
	More than 1500: ±(0.3% of rdg+3.5)	More than 2732: ±(0.3% of rdg+7)	0.2	1				
	PL-II	21	0.0 to 1290.0	32 to 2354	Full range: ±(0.15% of rdg+0.7)	Full range: ±(0.15% of rdg+2)	0.2	1
	Nicrocil-NiSiL	22	0.0 to 1300.0	32 to 2372	Full range: ±(0.15% of rdg+1.0)	Full range: ±(0.15% of rdg+3)	0.2	1
KpvsAu7Fe	23	-272.0 to +26.0	-457 to +80	-272 to -250: ±(0.15% of rdg+1.6)	-459 to -418: ±(0.15% of rdg+4)	0.2	1	
				More than -250: ±(0.15% of rdg+1.1)	More than -418: ±(0.15% of rdg+3)	0.2	1	
L	24	-200.0 to +900.0	-328 to +1652	-200 to 0: ±(0.15% of rdg+1.2)	-328 to +32: ±(0.15% of rdg+3)	0.2	1	
				More than 0: ±(0.15% of rdg+0.7)	More than 32: ±(0.15% of rdg+2)	0.2	1	
U	25	-200.0 to +600.0	-328 to +1112	-200 to 0: ±(0.15% of rdg+1.2)	-328 to +32: ±(0.15% of rdg+3)	0.2	1	
				More than 0: ±(0.15% of rdg+0.7)	More than 32: ±(0.15% of rdg+2)	0.2	1	
Resistance thermometer bulb	Pt100	30	-200.0 to +650.0	-328.0 to +1202.0	Full range: ±(0.15% of rdg+0.6)	Full range: ±(0.15% of rdg+1.2)	0.2	0.5
	JPt100	31	-200.0 to +550.0	-328.0 to +1022.0	Full range: ±(0.15% of rdg+0.6)	Full range: ±(0.15% of rdg+1.2)	0.2	0.5
	Ni508.4	32	-50.0 to +150.0	-58.0 to +302.0	Full range: ±(0.15% of rdg+0.7)	Full range: ±(0.15% of rdg+1.4)	0.2	0.5
Honeywell radiametric pyrometer	RH	40	400.0 to 1800.0	752 to 3272	400 to 700: ±52	752 to 1292: ±95	5.1	10
					700 to 900: ±(0.3% of rdg+5.0)	1292 to 1652: ±(0.3% of rdg+10)	0.6	2
					900 to 1200: ±(0.15% of rdg+2.0)	1652 to 2192: ±(0.3% of rdg+5)	0.3	2
	More than 1200: ±(0.15% of rdg+0.8)	More than 2192: ±(0.15% of rdg+2)	0.2	1				
	RI	41	400.0 to 1780.0	752 to 3236	400 to 700: ±13	752 to 1292: ±24	1.3	3
					700 to 1000: ±(0.3% of rdg+0.3)	1292 to 1832: ±(0.3% of rdg+6)	0.4	2
More than 1000: ±(0.15% of rdg+1.0)					More than 1832: ±(0.15% of rdg+3)	0.2	1	

Chapter 3 NAMES AND FUNCTIONS OF COMPONENT PARTS

3-1 Entire Configuration

The following figure shows the entire configuration of the DPR500 2-pen model and names of component parts.

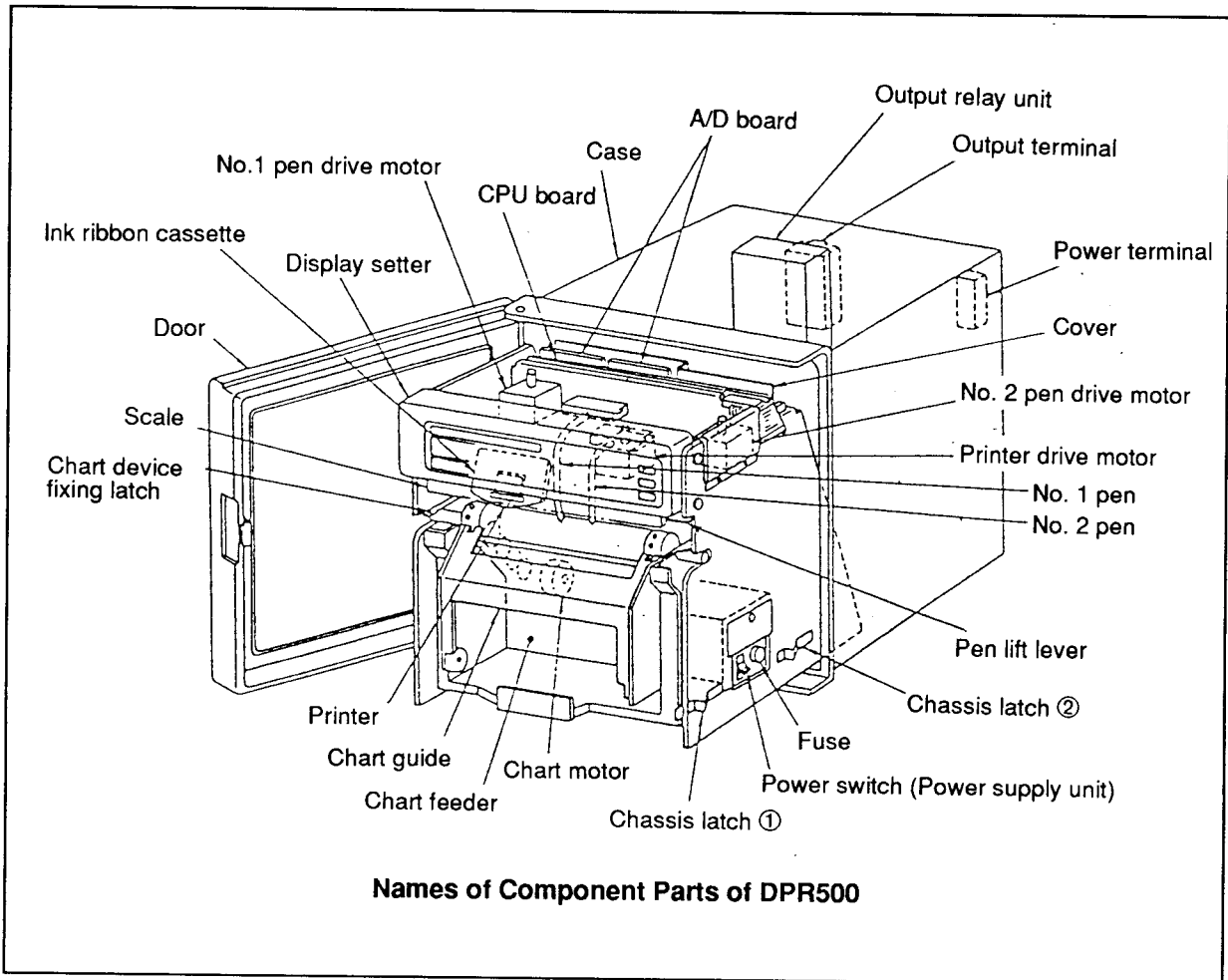

3-2 Configuration of Component Parts

- (1) Case
The case consists of the case body, terminals, and terminal cover. It is provided with radiation holes.
- (2) Door
The door consists of the frame, glass, and gasket. It is constructed as a handy dust-proof structure of the left hinge type.
- (3) Chassis
The chassis is drawable with drawing latches mounted at the lower right part.
Chassis latch ① is used for turning ON and OFF the power supply, and replacing the fuse, chart, ink ribbon cassette, and pen, while chassis latch ② is used for maintenance and check only.
Don't draw out the chassis carelessly, otherwise the main body may be unlatched to drop down.
Don't use these chassis latches usually.
- (4) Printer
The printer consists of the wire dot printer head, head feed device, head feed motor, ink ribbon cassette, ribbon feed motor, and other component parts.
- (5) Chart Feed Device
The chart feed device consists of the chart feed roller, chart feed motor, reduction gears, housing, and other component parts.
- (6) Pen Drive Unit
The pen drive unit consists of the pen, pen arm, pen lift device, stepping motor, pulley, drive cable, and other component parts.
- (7) Display Setting Unit
The display setting unit is divided into the setter and indicator, and it consists of the component parts shown on next page.
The setter uses flat keys. A chart illumination lamp is attached as an option.
- (8) Power Supply Unit
The power supply unit consists of the switch, fuse, power transformer, PCB ass'y, power chassis, and clock backup dry battery holder.
A chart illumination lamp power supply is attached as an option.
The power supply unit having a different part number is mounted according to the options.
- (9) PCB Assemblies
The PCU assemblies consist of a CPU PCB ass'y composed of a microprocessor PCB and a driver PCB, an A/D converter PCB ass'y composed of an A/D PCB, an option PCB ass'y for contact output relays and contact input photocoupler, and an option communication PCB ass'y.
- (10) Input Terminals
Input terminals consist of terminals and a PCB.
Input terminals consist of 3 terminals/channel corresponding to resistance thermometer inputs.
- (11) Other Terminals
In addition to power terminals, six event output terminals, three external contact input terminals, and one set of communication terminals are provided as an option.

Configuraton of Display Setting Unit

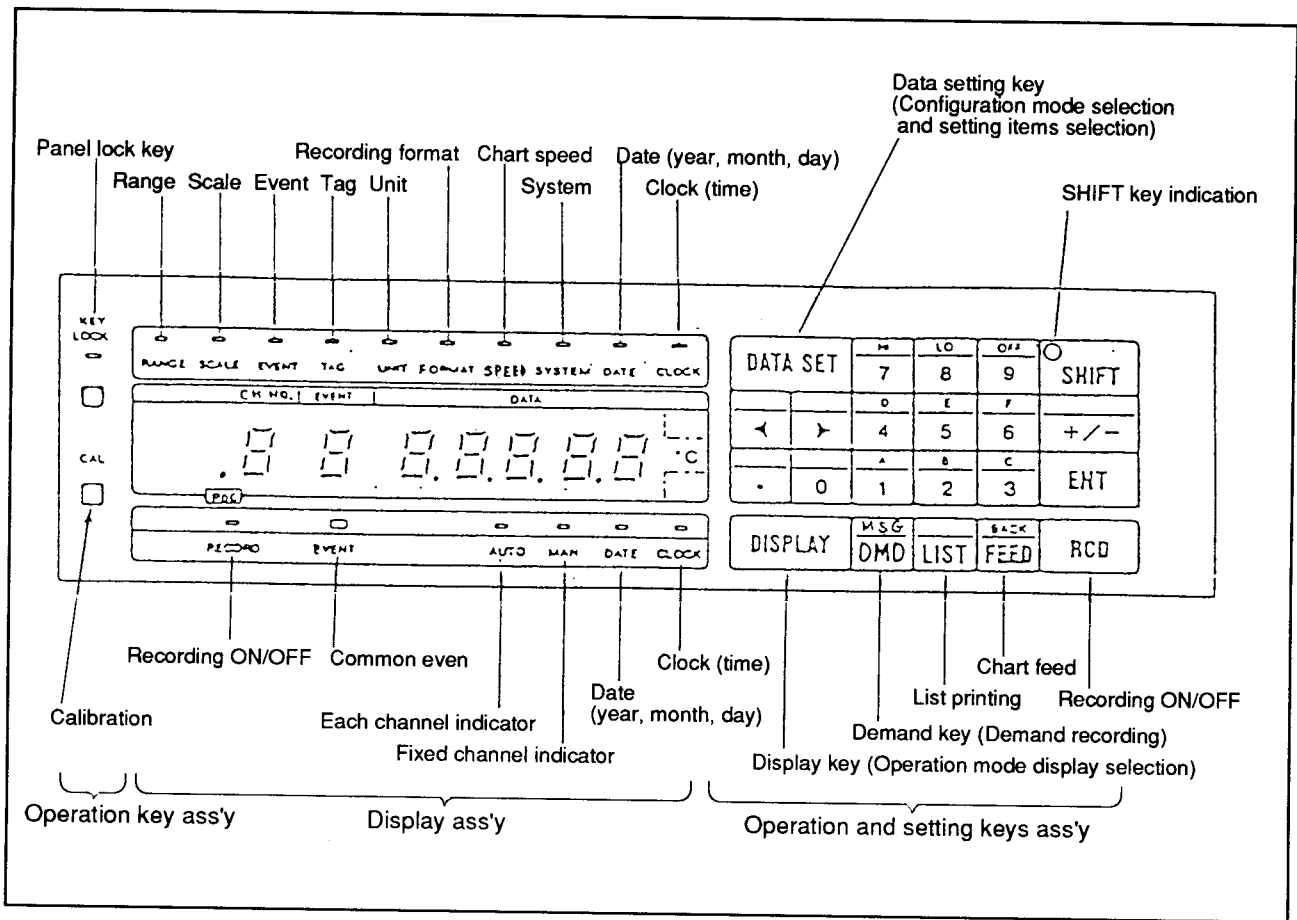

Chapter 4 INSTALLATION

4-1 Mounting Place

Select a mounting place conforming to the following requirements.

- (1) A place at about normal temperature without any noticeable temperature change
- (2) A place free of corrosive gases
- (3) A place free of low or high humidity
- (4) A place free of mechanical vibrations
- (5) A place free of dust particles, soot, etc.
- (6) A place where is not affected by electric noises
- (7) A place free of a strong magnetic field

4-2 Mounting Method

- (1) Don't tilt the instrument backward more than 30° from the horizontal position.
- (2) Use a mounting panel made of a steel plate having a thickness of more than 3mm.
- (3) Insert the instrument case from the panel cutout.
- (4) Fix the right and left panels of the instrument securely by the attached mounting brackets.

4-3 Mounting Dimensions and Panel Cutout Size

External Dimensions

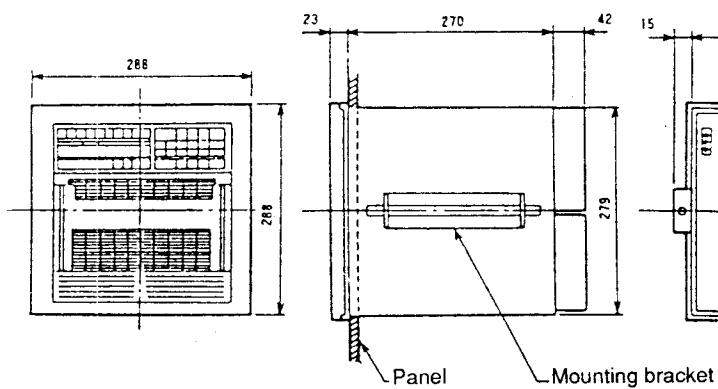

Panel Cutout Size

Unit: mm

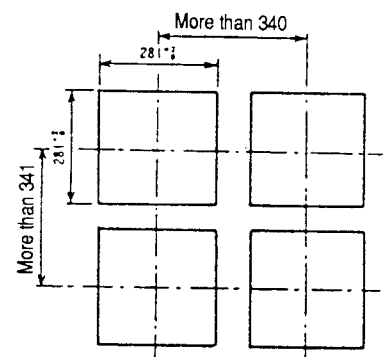

Chapter 5 CONNECTIONS

5-1 Cautions on Connections

- (1) Since a digital instrument is apt to be easily affected by electric noises, those which are negligible in case of an analog instrument may cause a trouble or an erroneous function in case of the digital instrument. Connect cables with due care according to the instructions given in this chapter for the purpose of preventing the influences of noises.
- (2) Use crimp style terminals conforming to M4 screws.
- (3) Connect cables to the corresponding terminals after confirming to the instrument model number (including options). After connections, confirm them.
- (4) If a DC voltage input exceeding $\pm 30\text{V}$ is input, set the input channel range type to code number 07 ($\pm 50\text{V}$) before starting connections. If a high voltage is continuously input for several hours when the range type is set to a code number other than specified above, internal circuits may be broken.
- (5) Separate the input/output signal cable more than 30cm from a drive power cable of higher than 100V and the power cable. Don't connect it together with the drive power cable and power cable through the same conduit or duct.
- (6) Don't use any unused terminals as a relaying terminal.

5-2 Input/Output Signals

- (1) Thermocouple input signal cable
In case of thermocouple inputs, connect the thermocouple cable to the terminals. If this wiring distance is long or the sensor is connected to the terminals, connect thermocouple input signals by using an extended compensating lead wire. Use a shielded compensating lead wire.
- (2) Cables for those other than thermocouple inputs and digital input/output cables
 - Use a shielded instrumentation polyethylene-insulated vinyl-sheathed cable conforming to JKEV-SB (JCS-364) or equivalent. (Instrumentation twisted shielded cables as a general term)
 - Use a shielded multiconductor microphone cord (MVVS), if the electromagnetic induction is comparatively small.
- (3) External input contacts
 - Apply no-voltage contact inputs. Use contacts for a very low current.
(Input opening voltage: About 6V, Input short-circuit current: About 5mA)
 - Hold a contact signal for longer than 0.5 second.
- (4) Communication signal cable
 - Be careful not to short plus and minus communication terminals, otherwise the communication circuit may be broken.
 - Don't set DCP550 to the same addresses as those of another instrument connect to the same RS-485 communication line.

5-3 Grounding

Connect the instrument to the ground by one-point grounding at the G terminal. Don't perform any jumper wiring. Prepare a grounding terminal board (earth bar), if it is difficult to ground the instrument with a shielded wire.

- Grounding type : Category 3 grounding or over (Lower than 100Ω)
- Grounding wire : An annealed copper wire of more than 2mm² (AWG14)
- Grounding wire length : Max. 20m

5-4 Instrument Power Supply

- A 600V vinyl wire (JIS C3307) is recommended for power wiring.
- Obtain the DPR500 power supply from a single-phase instrument power source without being affected by noises as much as possible.
- If it is recommended to add an insulation transformer and also use a line filter, if noises are introduced much from the power source. (Recommendable line filter; ZAC2205-00 manufactured by TDK or equivalent)
- Shorten the wiring from the line filter as much as possible, and twist it to suppress noises.
- Don't bundle the primary and secondary of the power line, or don't connect them through the same conduit or duct after taking the countermeasures against noises.

5-5 Noise Generation Sources and Reduction Measures

- (1) The following noise generation sources are possible in general.
 - Relays and contacts
 - Solenoid coils and solenoid valves
 - Power line (higher than 100V AC, in particular)
 - Inductive load
 - Motor commutator
 - Phase angle control SCR
 - Radio communication units
 - Welding machines
- (2) Noise reduction measures
 - A CR filter is effective for quick rising noises.
(Recommendable CR filter: XEB120033 manufactured by MATSUO ELECTRIC Co., or equivalent)
 - A varistor is effective for noises having a high crest value. However, be careful since the varistor results in a short-circuit mode, if it becomes defective.

5-6 Use of Round Crimp Style Terminals

Use round crimp style terminals so as not to disconnect any cable from terminals when the instrument is used at a place subjected to severe vibrations and shocks.

The analog input ass'y of this instrument is designed on assumption that M4 size round crimp style terminals are used. Use round crimp style terminals to the analog input ass'y without fail for the purpose of preventing a careless contact failure or other troubles.

5-7 Terminal Connection Diagram

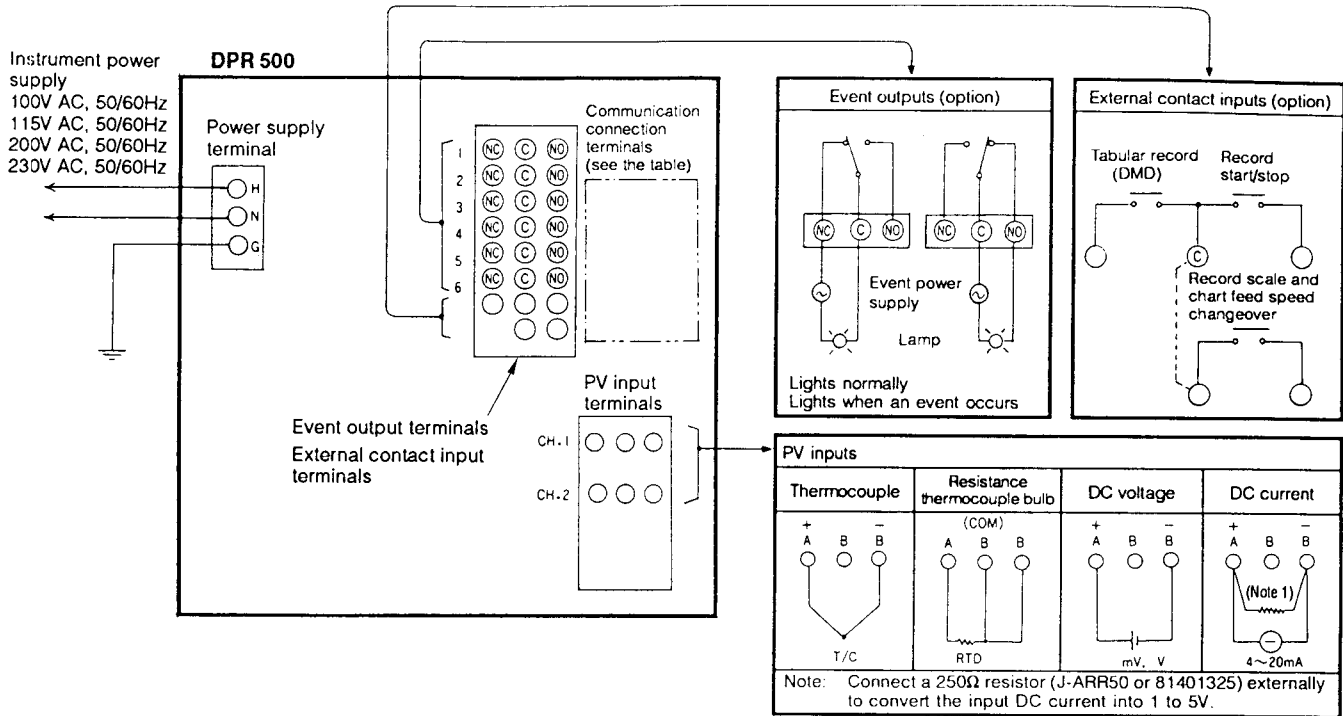

Communication Connection Terminals (option)

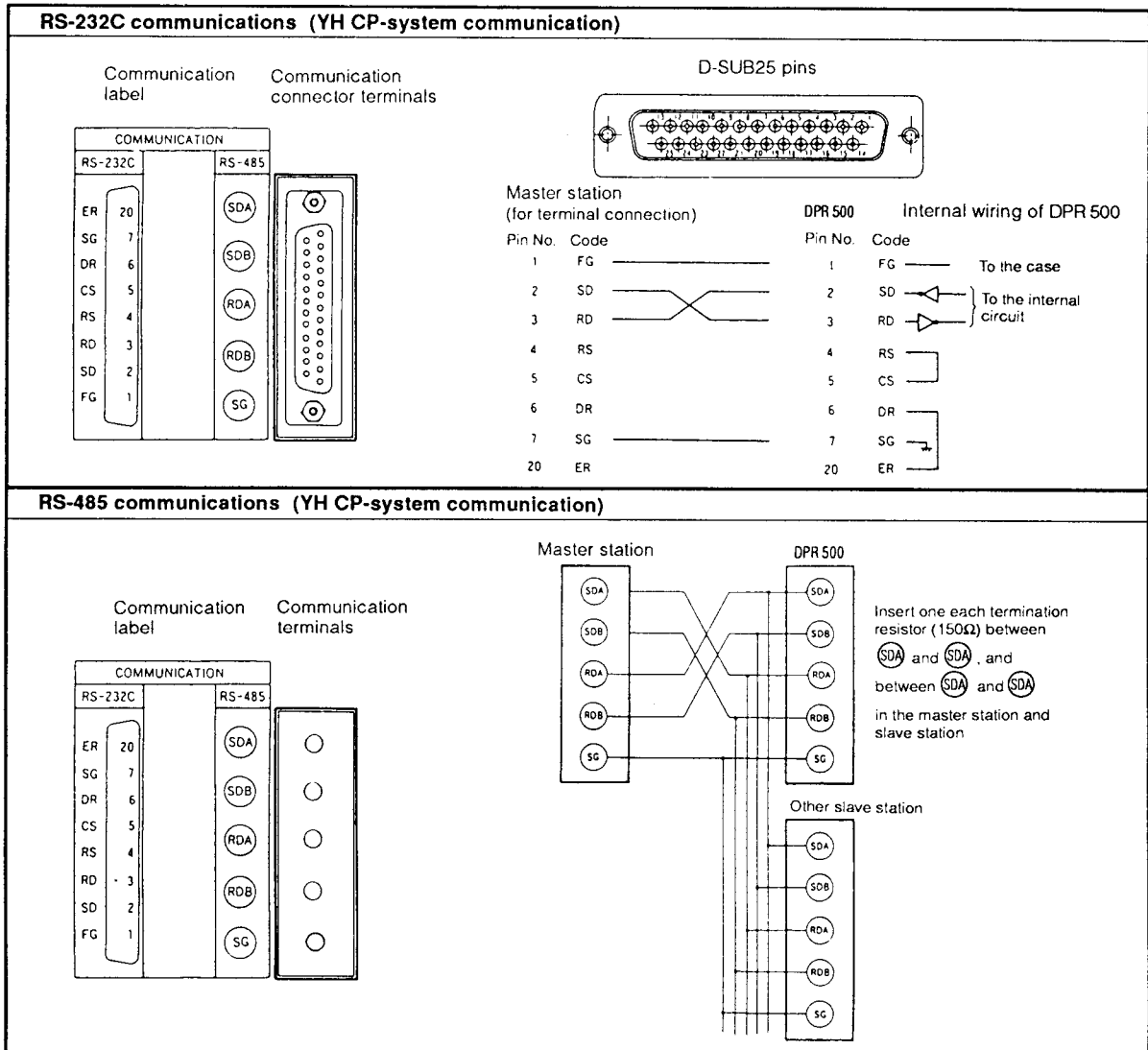

Chapter 6 PREPARATION FOR OPERATION

6-1 Confirmation of Recording Stop

Make sure that the "RECORD" LED which indicates the ON/OFF conditions of recording goes out. If it is lighting, press RCD key to turn OFF the recording.

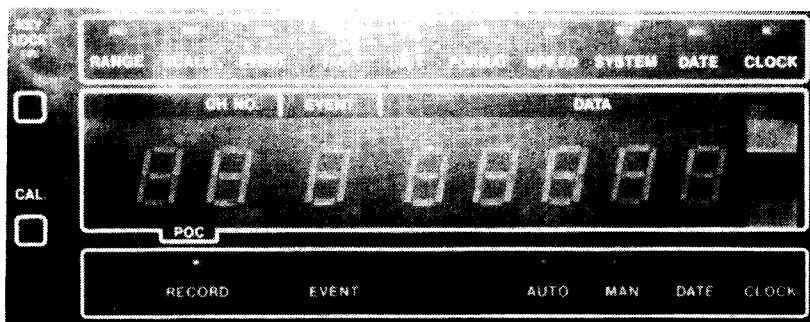

6-2 Loading of Chart

Shaffle the chart lightly before loading it.

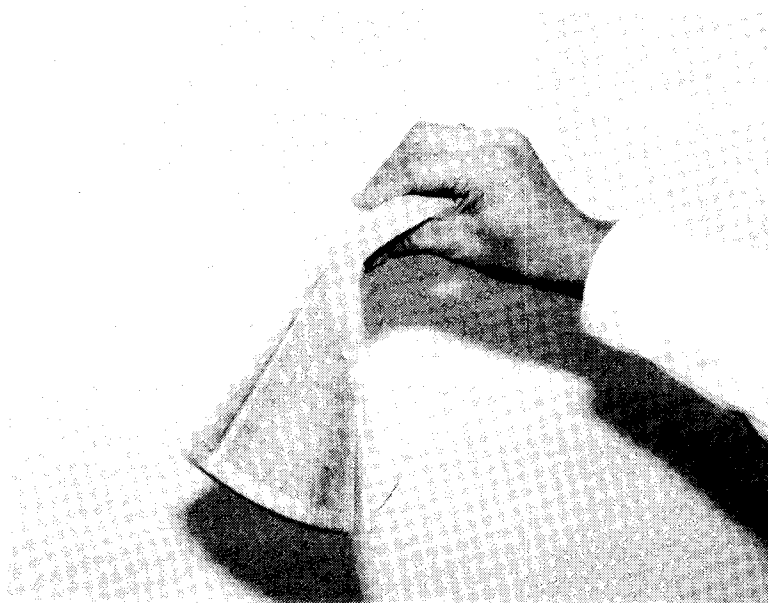

Hold the chart cassette flanges by both hands, and tilt the chart cassette toward you.

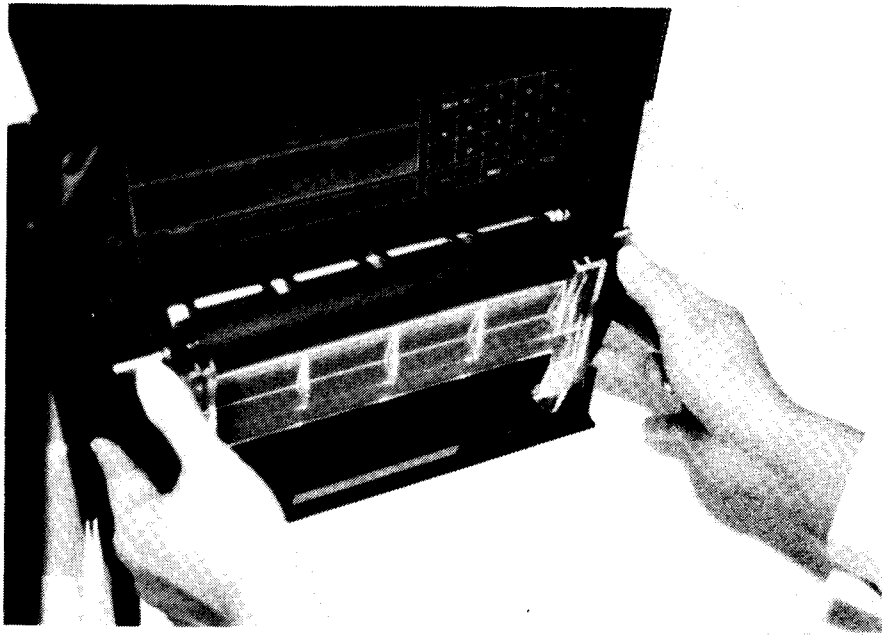

Tilt the chart guide toward you.

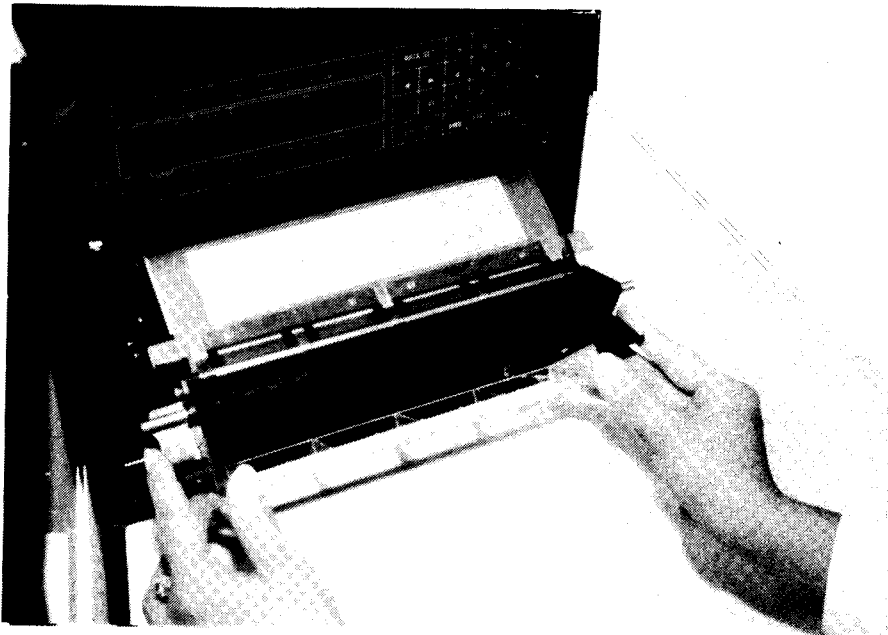

Open the chart holder upward while pressing it backward.

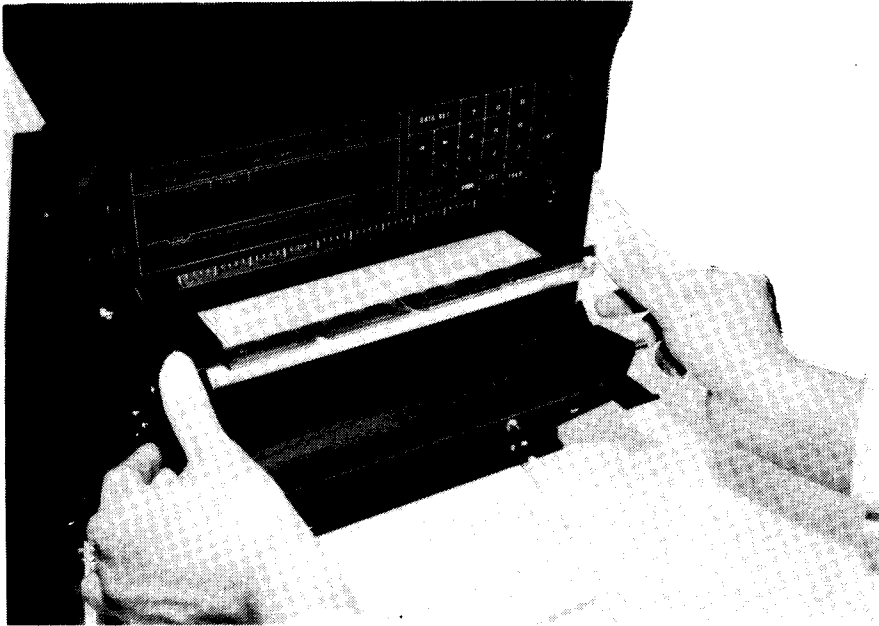

Insert a chart into the chart holder from this side, and lead its tip through toward the front of the instrument.

Caution: Insert the chart into the chart holder completely, otherwise the chart is not fed normally or other troubles may result.

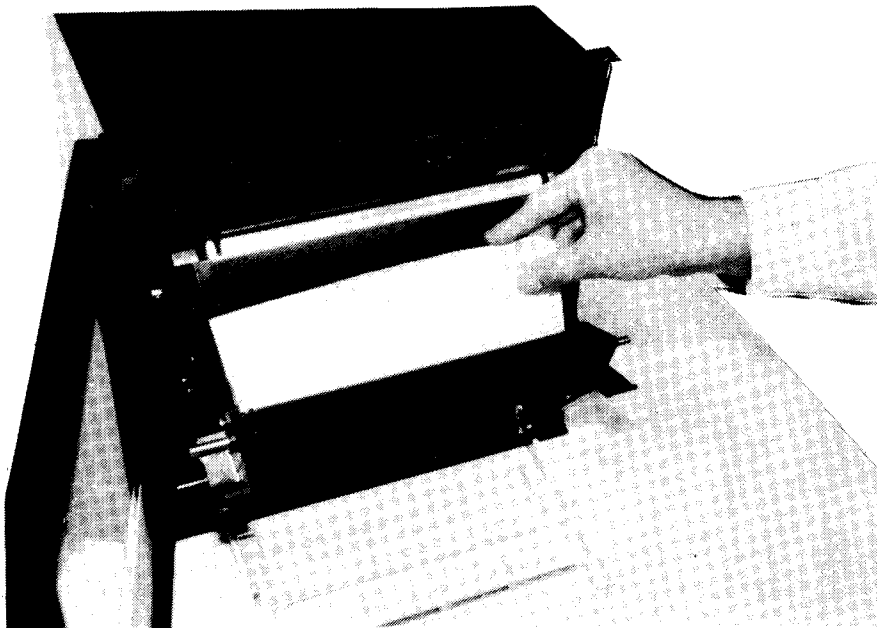

After taking out the chart toward you by about fourfold size, set the chart to the sprocket correctly, and reset the chart holder as before.

Caution: Make sure that the time line of the chart is horizontal as viewed from the front of the instrument.

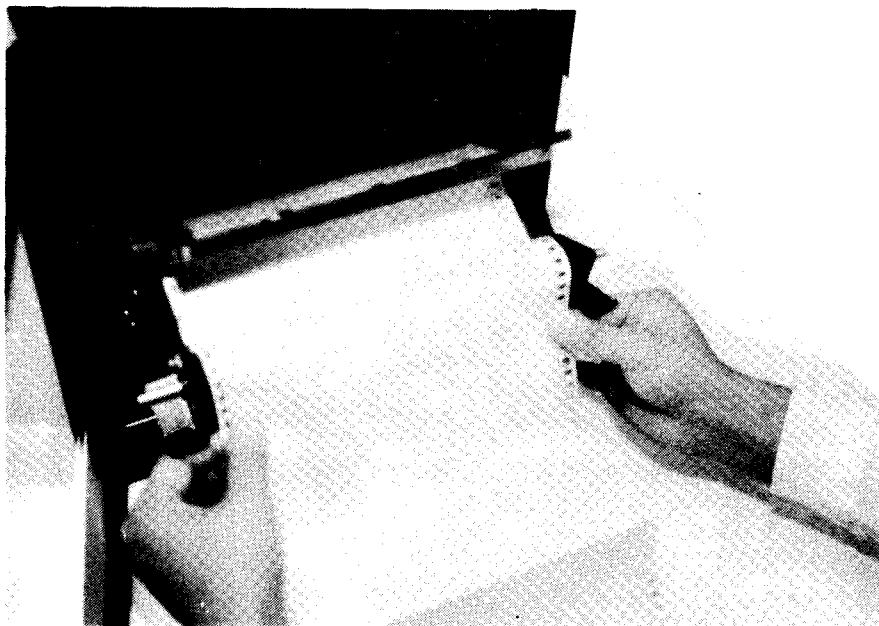

Hold the chart cassette flanges by both hands, and put the chart cassette into the chassis. Reset the chart guide as before until it is latched.

Purchase number of chart: 80340408-001 (containing 10 pads)

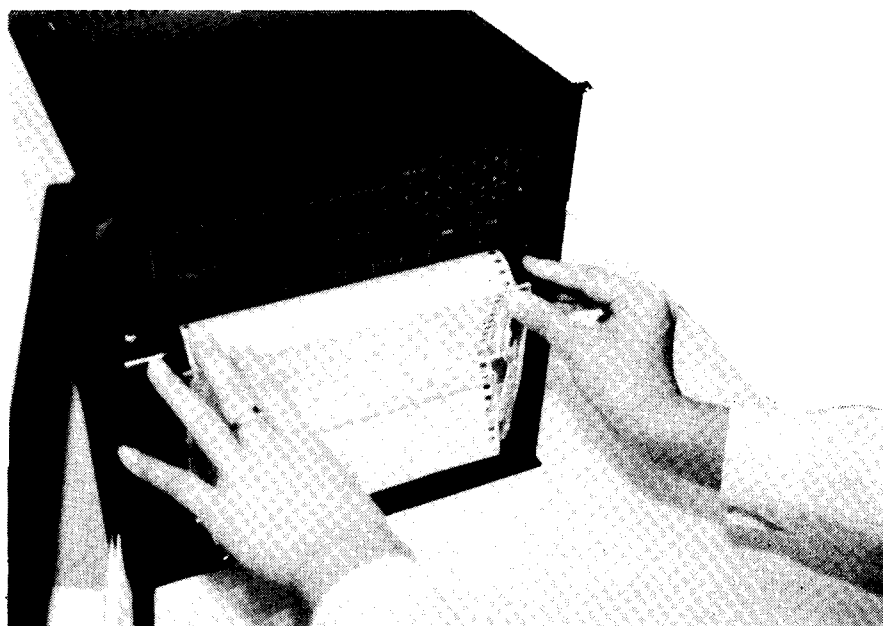

6-3 Mounting of Ink Ribbon Cassette

Mount the ink ribbon cassette after the wire dot head has been separated from the pen cartridge by moving it lightly rightward and leftward.

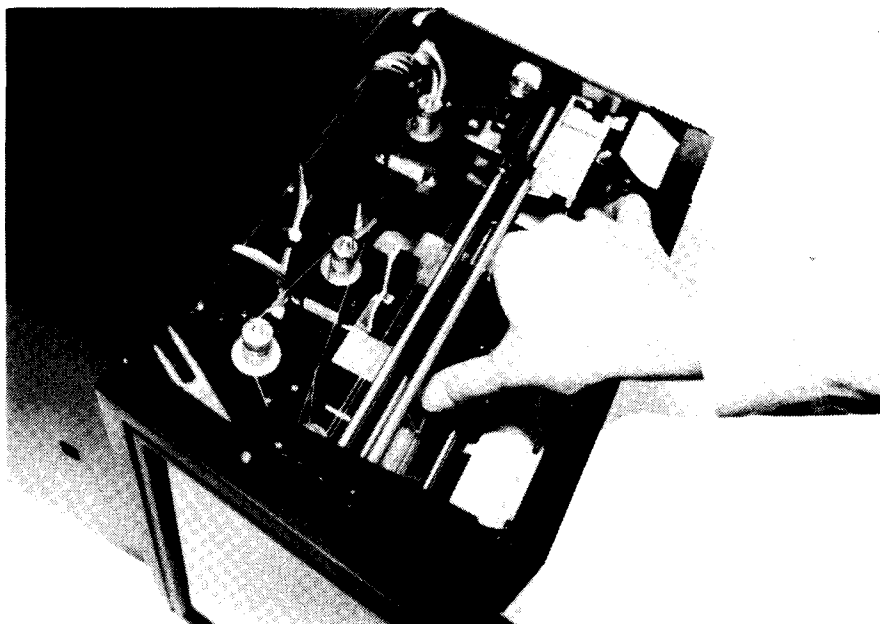

Caution: Make sure that the ink ribbon is inserted into the clearance between the wire dot head and chart.

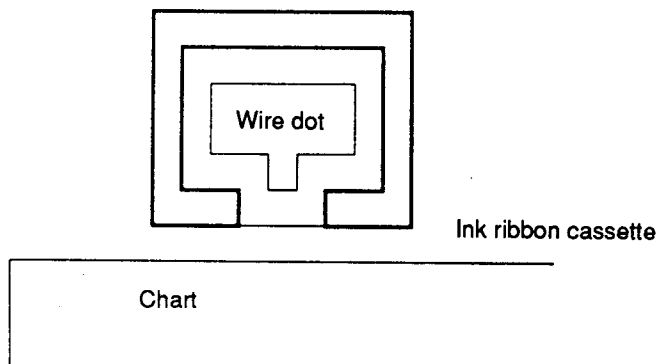

6-4 Mounting of Pen Cartridge

Hook the left claw of the pen cartridge to the left groove of the pen cartridge holder.

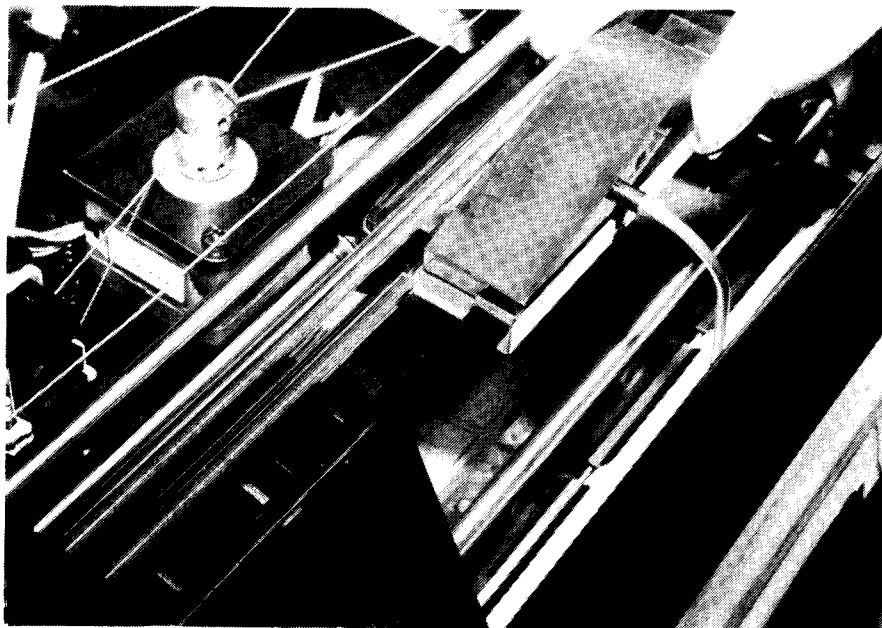

Fix the pen cartridge by inserting it into the pen cartridge holder from both sides.



Caution: Don't press the pen cartridge from the top when fixing it, otherwise the pen cartridge holder may be broken. Fix the pen cartridge and the holder claws by pressing them from both sides without fail.

Mount No. 1 pen and No. 2 pen in the same way.

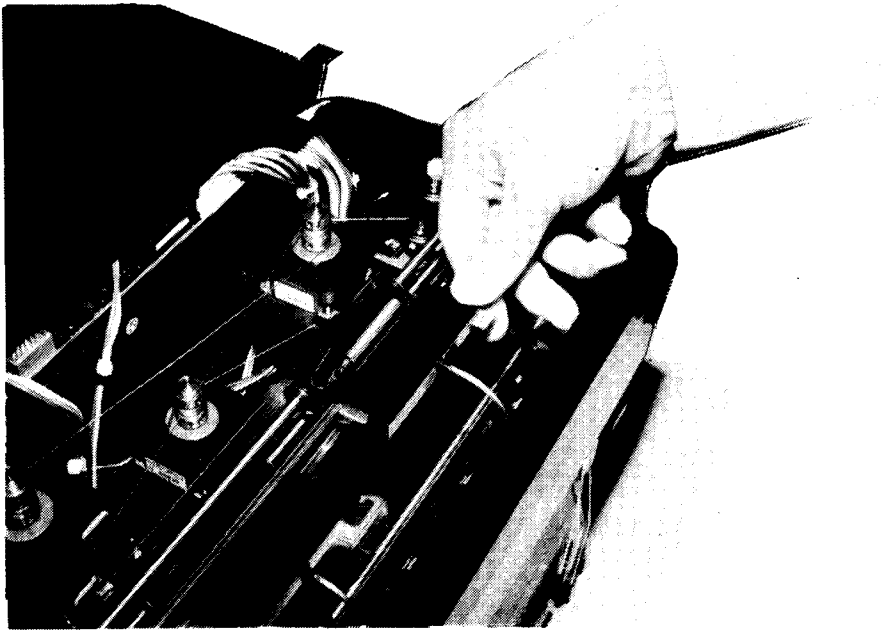

Caution: Don't apply any excessive force when moving the pen cartridge holder rightward and leftward.
Don't hold the photosensor portion shown in the photo when moving the wire dot head.

Pen cartridge part numbers and colors: No. 1 pen : Red 80340571-001
No. 2 pen : Green 80340571-002
No. 1, 2 pens (one red and one green each):
80340571-003
Ink ribbon cassette part number : 80340571-001

6-5 Mounting of Dry Batteries for Backing Up the Clock

Three SUM-3 dry batteries are used for backing up the clock.

By drawing out the instrument body while pressing the chassis latch (1), the dry battery case is accessible above the POWER switch.

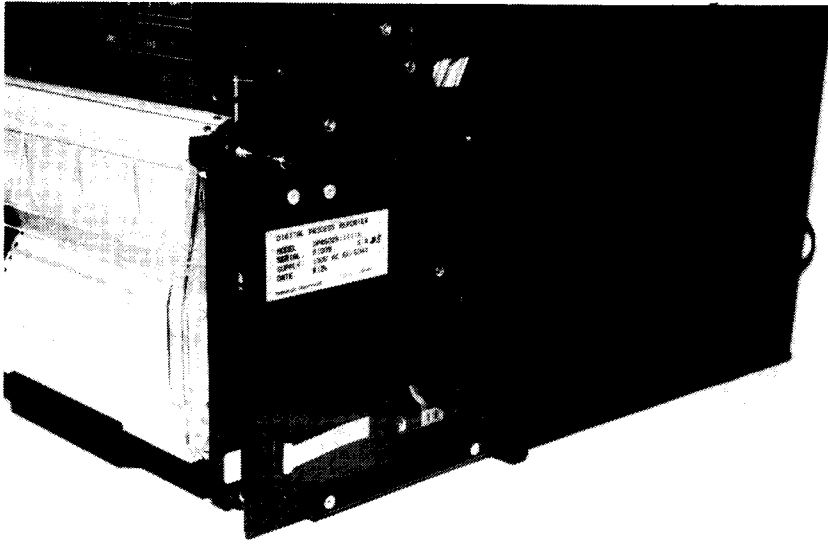

Remove the dry battery case cover after loosening its screws.

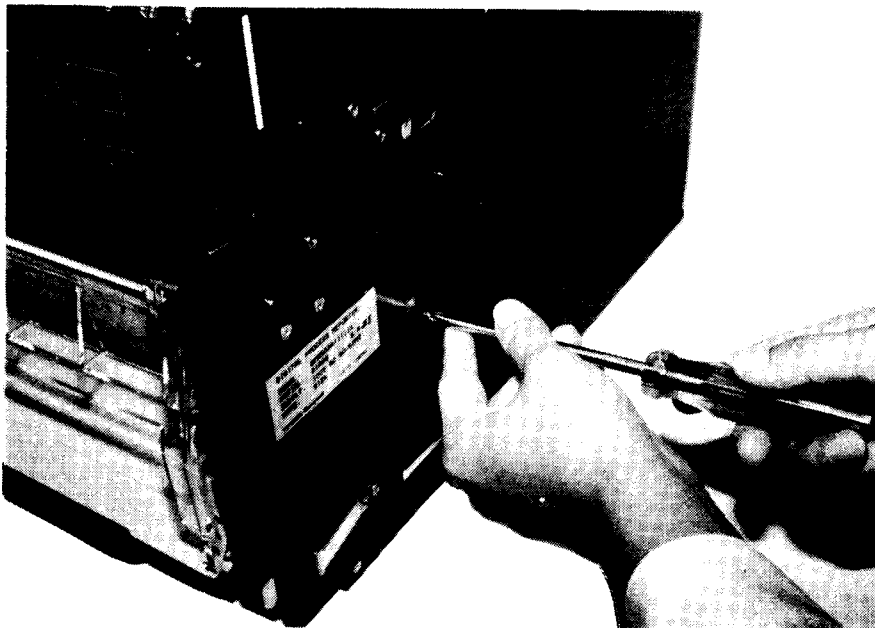

Put three SUM-3 dry batteries with their correct polarities, and then, mount the case cover.

6-6 Mounting of Power Fuse

Mount the attached fuse according to the power voltage.

- 100V system (100V AC, 115V AC) 1A fuse
- 200V system (200V AC, 230V AC) 0.5A fuse

The fuse holder is mounted on the right side of the POWER switch.

6-7 POWER Switch and RCD (Recording ON/OFF) Key

Turn on the POWER switch after wiring, chart loading, mounting the ink ribbon, pen cartridge, dry batteries, and fuse.

The recorder starts operating to be ready for setting the configuration.

Set each item according to the setting procedure as described in Chapter 7 [Setting (Configuration) before Starting Operation].

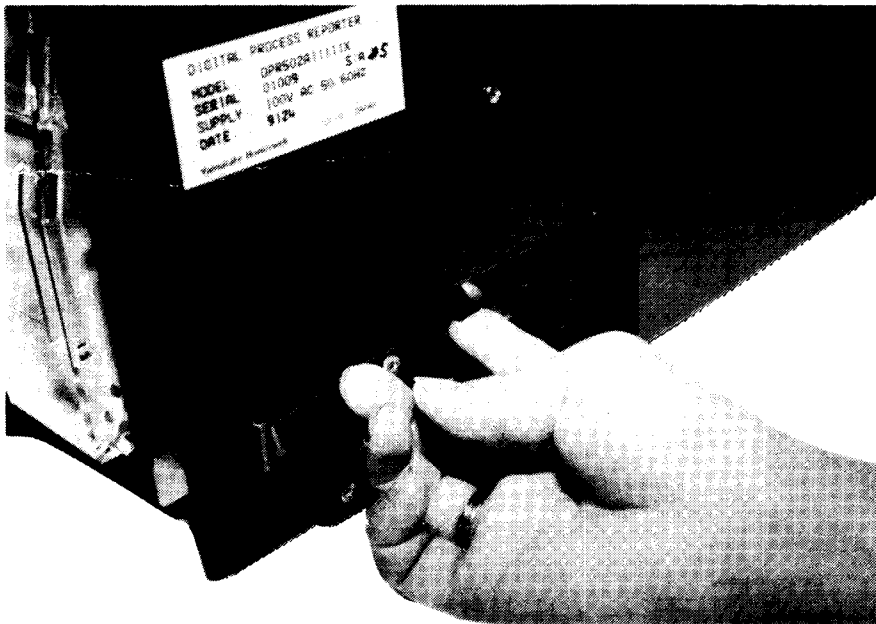

Chapter 7 SETTING (CONFIGURATION) BEFORE STARTING OPERATION

7-1 Display Arrangement in Configuration Mode

Configuration data are set by using the configuration mode setting keys and indicator.

Select each setting item by DATA SET keys. Data contents are indicated on the indicator. The setting arrangement of the indicator differs every setting item as shown in the following setting arrangement.

Arrangement of Set Points

Setting item	8	8	8	8	8	8	8	8		
DATA SET	RANGE	0 indication	CH No.	1	1	Recording mode	2	Range code	3	Unit indication position
				2	4	Input conversion type	Dropout value		5	Burnout
				3	Selection range		0% value			
				4	100% value					
				5	Engineering range		0% value			
				6	100% value					
				7	Fixed value for deviation					
				8	PV bias					
	SCALE	0 indication	CH No.	1	#1 scale		0% value			
				2	100% value					
				3	#2 scale		0% value			
				4	100% value					
				5	6	Scale recording ON/OFF	7	Switching system		
				6	Automatic switching set value					
7				Automatic switching differential set point						
EVNET	0 indication	CH No.	1,2,3,4	8	Event type	Relay No.				
			5,6,7,8	Event set point						
			9,A,B,C	Event differential set point						
TAG	0 indication	CH No.	Code No.=		Character code (Hexadecimal indication)					
UNIT			Character No.							
FORMAT			9	Recording format	10	Phase synchronization				
SPEED	11	Chart speed	Code No. 1,2		Chart speed (Reference value)					
SYSTEM			Code No. 1	12	Keylock level					
			No. 2,3,4		See the User's Manual for DPR500 having a communication function					
DATE		Year		Month	—	Day				
CLOCK				Hour	—	Minute				
DISPLAY	AUTO	P.O.C.	CH No.	Event	PV value					
	MAN			Event	PV value					
	DATE		Year		Month	—	Day			
	CLOCK				Hour	*	Minute			

7-2 Configuration Setting Codes Table

Setting codes are shown below every setting contents.

Configuration Setting Codes Table

1 Recording mode				3 Unit indication position		9 Recording format	
1: OFF (Off mode) 2: DISP (Display mode) 3: RCD (Recording display mode)				1: Upper side 2: Center (°C) 3: Lower side 4: No indication		1: Analog 2: Analog + Digital 3: Zone	
2 Range cpde				4 Input operation type		10 Phase synchronization (P.O.C.)	
Code	Type	Range	Remarks	1: PV value 2: Deviation bet. CHs (Ref. CH – Working CH) 3: Deviation bet. CHs (Working CH – Ref. CH) 4: Devi. from fixed val. (Fixed val. – Work. CH) 5: Devi. from fixed val. (Work. CH – Fixed val.) 6: Square root extraction		1: OFF 2: ON	
00	mV	± 20	D.C. (Linear scaling)	5 Burnout		11 Chart speed (mm/h)	
01		± 40		1: OFF 2: UP 3: DOWN		1: 5 9: 300	
02		± 60				2: 10 10: 600	
03		±200				3: 12.5 11: 750	
04	V	± 2				4: 25 12: 1500	
05		± 6				5: 50 13: 3000	
06		± 20				6: 75 14: 4500	
07		± 50			7: 100 15: 6000		
10	R	0~1760	Thermo- couple (°C)	6 Scale recording		12 Keylock level	
11	S	0~1760		1: #1-OFF, #2-OFF 2: #1-ON, #2-OFF 3: #1-OFF, #2-ON 4: #1-ON, #2-ON		Lock function Operation keys	
12	B	400~1820		7 Scale switching system		1 Data setting & recording operation	
13	K	-200~1370		1: No switching 2: Automatic 3: Remote input		2 Data setting	
14	E	-200~ 800		8 Event type		3 A part of data setting	
15	J	-200~1100		Hi (H): HIGH LO (L): LOW OFF (-): OFF		The above keys plus	
16	T	-200~ 400				SHIFT RCD	
17	Ni-NiMo	0~1200				MSG BACK LIST	
18	WRe0-26	0~2320				DMD FEED	
19	WRe5-26	0~2320				The above keys plus EVENT, FORMAT, and SPEED of	
20	PR40-20	0~1880				DATA SET keys	
21	PL-II	0~1290					
22	Nicrosil-Nisil	0~1300					
23	KPvsAu7Fe	-272~ 26					
24	L	-200~ 900					
25	U	-200~ 600					
30	Pt100	-200~ 650	Resistance thermometer (°C)				
31	JPt100	-200~ 550					
32	Ni508.4	-50~ 150	Radiation thermometer (°C)				
40	RH	400~1800					
41	RI	400~1780					

7-3 Setting Procedure Table

The setting procedure of the configuration items is shown below.

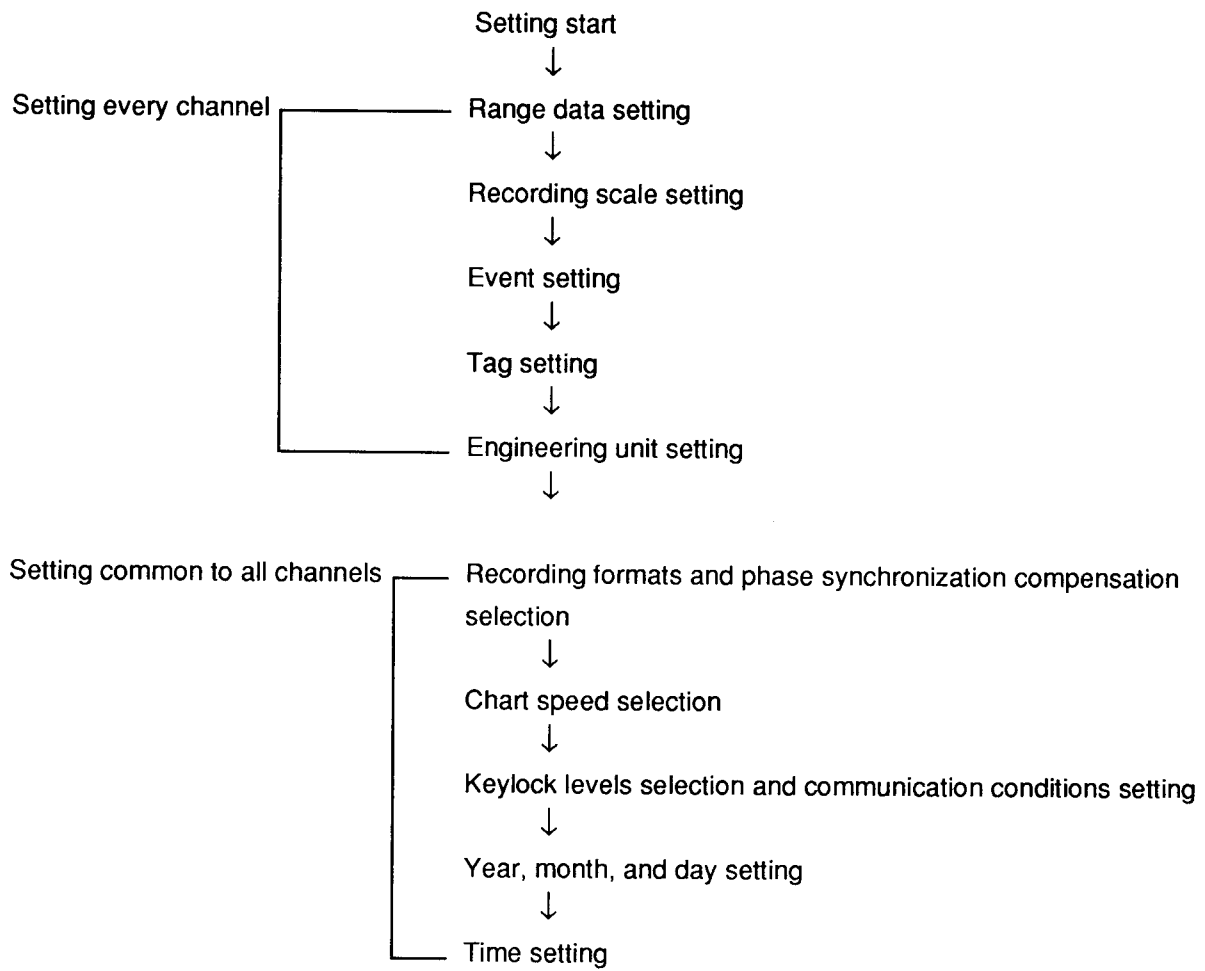

7-4 Common Key Operation

The following operation is common to each configuration data setting.

■ Transfer to the next setting procedure. (Entry of setting data)

Setting operation: Press ENT key.

Example; Transfer from setting procedure 1 to setting procedure 2.

CH	No.	Setting procedure	Recording mode	Range code	Unit LED position
0	1	1	3	1	3
					2

Press ENT key.

CH	No.	Setting procedure	Input operation type	Dropout value	Burnout direction selection
0	1	2	1		2

■ Return to the last setting procedure during data setting.

Setting operation: Press ENT key after pressing SHIFT key.

Example; Return to setting procedure 1 from setting procedure 2.

CH	No.	Setting procedure	Input operation type	Dropout value	Burnout direction selection
0	1	2	1		2

Press ENT key after pressing SHIFT key.

CH	No.	Setting procedure	Recording mode	Range code	Unit LED position
0	1	1	3	1	3
					2

■ Data change during setting.

Setting operation: Reset data after shifting the cursor by ← → keys.

CH	No.	Setting procedure	Recording mode	Range code	Unit LED position
0	1	1	3	1	3
					2

A corresponding character flickers at the cursor position.

■ Setting contents error

The entire indicator flickers, if setting is in error after pressing ENT key. Repeat setting again by ENT key.

7-5 Input Range Setting

■ "RANGE" selection

Select "RANGE" by pressing DATA SET key.

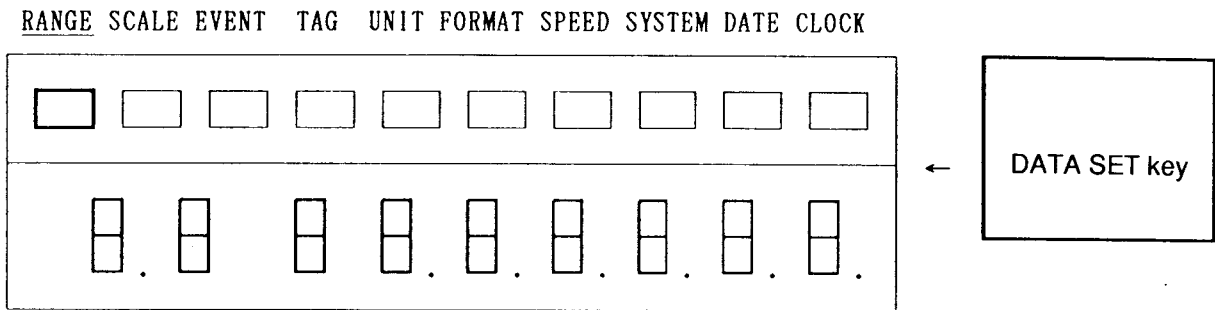

The LED lights at the selected item.

- Set a desired channel No. Assume that CH No. = 01 is set as an example.
Set 01 by ten keys after shifting the cursor to the CH No. indicating position by ← → keys. (The corresponding numeric flickers at the cursor position.) After this setting, the cursor shifts to the next setting item automatically.

CH	No.	Setting procedure	Recording mode	Range code	Unit LED position
0	1	1	3	0 6	1

□ "Range code" setting procedure 1

Recording mode, input range, unit LED indicating position

◆ Recording mode selection

The following recording modes are selectable every channel.

- 1: OFF (Neither recording nor display is done.)
- 2: DISP (Recording is not done, but display is done.)
- 3: RCD (Both display and recording are done.)

CH	No.	Setting procedure	Recording mode	Range code	Unit LED position
0	1	1	3	0 6	1

3: RCD (Both recording and display are done) is selected here.

◆ Range code (Input type) selection

A range code is selectable out of all codes every channel. For the range codes, see the setting data table.

CH	No.	Setting procedure	Recording mode	Range code	Unit LED position
0	1	1	3	0 6	1

◆ Unit indicating position selection

Select the unit LED position. The LED lights after this selection.

- 1: Upper column
- 2: Intermediate column
- 3: Lower column
- 4: No indication

Caution: If either thermocouple or resistance thermometer range code is selected, this setting is not necessary. Also, °F (intermediate column) is automatically selected by °C or model number selection.

CH	No.	Setting procedure	Recording mode	Range code	Unit LED position
0	1	1	3	0 6	1

- Proceed to the next setting procedure by pressing ENT key.

□ "Range code" setting procedure 2

Input operation type, reference CH No., dropout value, and burnout.

◆ Input operation type

This item is provided to determine whether an input value is displayed and recorded as it is or a deviation or a square root extraction result is displayed and recorded.

- 1: PV (input value)
- 2: Deviation between channels 1 (A PV bias value in the reference channel is neglected.)
(PV value in reference channel) – (PV value in working channel) + (PV bias value in working channel)
- 3: Deviation between channels 2 (A PV bias value in the reference channel is neglected.)
(PV value in working channel) – (PV value in reference channel) + (PV bias value in working channel)
- 4: Deviation from fixed value 1
(Fixed value) – (PV value in working channel) + (PV bias value in working channel)
- 5: Deviation from fixed value 2
(PV value in working channel) – (Fixed value) + (PV bias value in working channel)
- 6: Square root extraction
Set the square root extraction by a % value (corresponding to the input range span) of the input before square root extraction.

This square root extraction can be set only when linear scaling is set as a range code.

- The working channel means a channel where the setting operation is in progress at present.
- The reference channel means a channel other than the working channel. Assume that channel 1 serves as the working channel, and channel 2 serves as the reference channel.
- Accordingly, no channel deviation can be operated in case of channel 1 input only (1-pen model).
- A fixed value is set by setting procedure 7.
- A dropout value in square root extraction can be set.

Example) Assume that the input operation type is normal recording 1 (PV value).

CH	No.	Setting procedure	Input operation type
0	1	2	1

◆ Dropout value

This item is skipped automatically if an item other than 6 is selected.

Set a dropout value (%) when the square root extraction is selected as an input operation type.

Dropout value setting range: 0 ~ 99%

Example) Assume that the dropout value is set to 5%. A range of lower-limit 0 to 5% of an input value is cut before starting the square root extraction, and arithmetic operation is done as 0%.

CH	No.	Setting procedure	Input operation type	Dropout value
0	1	2	6	5

◆ Burnout

This item is provided to set the display and recording action when a thermocouple was broken.

No display is done if a code other than the thermocouple input is selected in the range code selection.

- 1: Burnout off
- 2: Burnout upscale
- 3: Burnout downscale

Example) Assume that the burnout upscale is selected.

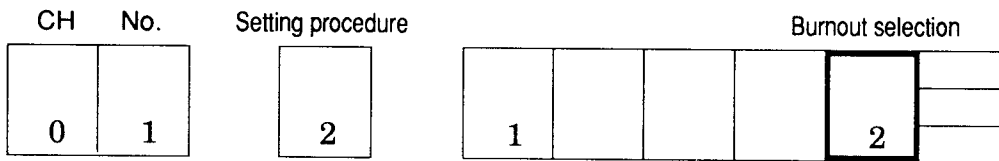

- Proceed to the next setting procedure by pressing ENT key.

The setting items in the next setting procedures 3 ~ 6 are set in a linear input (voltage). In case of a thermocouple input or a resistance thermometer input, these setting procedures are automatically skipped to setting procedure 7 (when the fixed value deviation operation is selected) or setting procedure 8.

□ "Range code" setting procedure 3

◆ Setting of a lower-limit value within a voltage (current) measuring range

Set a lower-limit value within the voltage (or current) measuring range when the input code is 01 ~ 07.

CH	No.	Setting procedure	Setting of lower-limit value within the voltage (current) measuring range
0	1	3	

- The decimal point position is automatically determined when a range code is set.

Example) Assume that input signals are 1 ~ 5V inputs.

Select 05 (±6V) in range code (input type) setting in setting procedure 1.

The following default value is displayed in setting procedure 3.

CH	No.	Setting procedure	Setting of lower-limit value within the voltage (current) measuring range
0	1	3	- 6. 0 0 0

Set 1.000V as a lower-limit value within the measuring range.

Setting method: Erase minus (–) indication by pressing +/- key.

Shift the digit by → key, and then, input "1".

The +/- key is effective irrespective of the cursor position.

CH	No.	Setting procedure	Setting of lower-limit value within the voltage (current) measuring range
0	1	3	0 1. 0 0 0

- Proceed to the next setting procedure by pressing ENT key.

□ "Range code" setting procedure 4

◆ Setting of a higher-limit value within the voltage (current) measuring range

Set a higher-limit value within the voltage (or current) measuring range when the input code is 01 ~ 07.

CH	No.	Setting procedure	Setting of higher-limit value within the voltage (current) measuring range																		
0	1	4	<table border="1" style="display: inline-table; vertical-align: middle;"> <tr><td> </td><td> </td><td> </td><td> </td><td> </td><td> </td></tr> <tr><td> </td><td> </td><td> </td><td> </td><td> </td><td> </td></tr> <tr><td> </td><td> </td><td> </td><td> </td><td> </td><td> </td></tr> </table>																		

- The decimal point position is automatically determined when a range code is set.

Example) Assume that input signals are 1 ~ 5V inputs.

Select 05 (±6V) in range code (input type) setting in setting procedure 1.

The following default value is displayed in setting procedure 4.

CH	No.	Setting procedure	Setting of higher-limit value within the voltage (current) measuring range																		
0	1	4	<table border="1" style="display: inline-table; vertical-align: middle;"> <tr><td>0</td><td>6.</td><td>0</td><td>0</td><td>0</td><td> </td></tr> <tr><td> </td><td> </td><td> </td><td> </td><td> </td><td> </td></tr> <tr><td> </td><td> </td><td> </td><td> </td><td> </td><td> </td></tr> </table>	0	6.	0	0	0													
0	6.	0	0	0																	

Set 5.000V as a higher-limit value within the measuring range.

CH	No.	Setting procedure	Setting of higher-limit value within the voltage (current) measuring range																		
0	1	4	<table border="1" style="display: inline-table; vertical-align: middle;"> <tr><td>0</td><td>5.</td><td>0</td><td>0</td><td>0</td><td> </td></tr> <tr><td> </td><td> </td><td> </td><td> </td><td> </td><td> </td></tr> <tr><td> </td><td> </td><td> </td><td> </td><td> </td><td> </td></tr> </table>	0	5.	0	0	0													
0	5.	0	0	0																	

- Proceed to the next setting procedure by pressing ENT key.

□ "Range code" setting procedure 5

◆ Setting of a lower-limit value of linear scaling (industrial range)

This item is provided to convert a lower-limit value of the measuring range into an actual unit scale.

Setting range: -19999 ~ +29999

CH	No.	Setting procedure	Setting of a lower-limit value of linear scaling (engineering range)																		
0	1	5	<table border="1" style="display: inline-table; vertical-align: middle;"> <tr><td> </td><td> </td><td> </td><td> </td><td> </td><td> </td></tr> <tr><td> </td><td> </td><td> </td><td> </td><td> </td><td> </td></tr> <tr><td> </td><td> </td><td> </td><td> </td><td> </td><td> </td></tr> </table>																		

- The decimal point position of an actual unit scale can be changed in this setting procedure 5 only.
- For changing the decimal point position, determine the decimal point position by shifting the cursor with ← → keys (The corresponding numeric flickers), and then, press "." key.

Caution: If the decimal point position is changed when setting the lower-limit value of linear scaling (engineering range), the decimal point positions of the following setting items are also changed. Reset the items employed, accordingly.

- Items requiring the resetting of the decimal point position
 - "RANGE" — Linear scaling (engineering range) higher-limit value
 - Fixed value of deviation
 - PV bias value
 - "SCALE" — Recording scale lower-limit value
 - Recording scale higher-limit value
 - Automatic switching set point
 - Automatic switching differential set point
 - "EVENT" — Event set value
 - Event differential set point

Example) Assume that input signals are 1 ~ 5V input and 0.0 ~ 100.0 is displayed and recorded.
 Select 05 (±6V) in range code (input type) setting of setting procedure 1.
 Set a measuring range of 1 ~ 5V in setting procedures 3 and 4.
 The following default value is displayed in setting procedure 5.

CH	No.	Setting procedure	Setting of the lower-limit value of linear scaling (engineering range)																		
0	1	5	<table border="1" style="display: inline-table; vertical-align: middle;"> <tr><td>0</td><td>0.</td><td>0</td><td>0</td><td>0</td><td> </td></tr> <tr><td> </td><td> </td><td> </td><td> </td><td> </td><td> </td></tr> <tr><td> </td><td> </td><td> </td><td> </td><td> </td><td> </td></tr> </table>	0	0.	0	0	0													
0	0.	0	0	0																	

Set 0.0% as the lower-limit value of linear scaling (engineering range).
 Set the decimal point position by ← → keys and "." (decimal point key).

CH	No.	Setting procedure	Setting of the lower-limit value within the voltage (current) measuring range																		
0	1	5	<table border="1" style="display: inline-table; vertical-align: middle;"> <tr><td>0</td><td>0</td><td>0</td><td>0.</td><td>0</td><td> </td></tr> <tr><td> </td><td> </td><td> </td><td> </td><td> </td><td> </td></tr> <tr><td> </td><td> </td><td> </td><td> </td><td> </td><td> </td></tr> </table>	0	0	0	0.	0													
0	0	0	0.	0																	

□ "Range code" setting procedure 6

◆ Setting of a higher-limit value of linear scaling (engineering range)

This item is provided to convert a higher-limit value of the measuring range into an actual unit scale.

Setting range: -19999 ~ +29999

CH	No.	Setting procedure	Setting of a higher-limit value of linear scaling (engineering range)																		
0	1	6	<table border="1" style="display: inline-table; vertical-align: middle;"> <tr><td> </td><td> </td><td> </td><td> </td><td> </td><td> </td></tr> <tr><td> </td><td> </td><td> </td><td> </td><td> </td><td> </td></tr> <tr><td> </td><td> </td><td> </td><td> </td><td> </td><td> </td></tr> </table>																		

Example) Assume that input signals are 1 ~ 5V input and 0.0 ~ 100.0% is displayed and recorded.

Select 05 (±6V) in range code (input type) setting of setting procedure 1.

Set a measuring range of 1 ~ 5V in setting procedures 3 and 4.

Set a lower-limit value of linear scaling (engineering range) in setting procedure 5.

The following default value is displayed in setting procedure 6.

CH	No.	Setting procedure	Setting of the higher-limit value of linear scaling (engineering range)																		
0	1	6	<table border="1" style="display: inline-table; vertical-align: middle;"> <tr><td>1</td><td>0.</td><td>0</td><td>0</td><td>0</td><td> </td></tr> <tr><td> </td><td> </td><td> </td><td> </td><td> </td><td> </td></tr> <tr><td> </td><td> </td><td> </td><td> </td><td> </td><td> </td></tr> </table>	1	0.	0	0	0													
1	0.	0	0	0																	

Set 100.0% as the higher-limit value of linear scaling (engineering range)

CH	No.	Setting procedure	Setting of the higher-limit value of linear scaling (engineering range)																		
0	1	6	<table border="1" style="display: inline-table; vertical-align: middle;"> <tr><td>0</td><td>1</td><td>0</td><td>0.</td><td>0</td><td> </td></tr> <tr><td> </td><td> </td><td> </td><td> </td><td> </td><td> </td></tr> <tr><td> </td><td> </td><td> </td><td> </td><td> </td><td> </td></tr> </table>	0	1	0	0.	0													
0	1	0	0.	0																	

The decimal point position is fixed to the same position as in the lower-limit value.

- Proceed to the next setting procedure by pressing ENT key.

□ "Range code" setting procedure 7

◆ Setting of a fixed value for deviation

This setting procedure is skipped to setting procedure 8 in all setting other than the setting of fixed value deviation recording being preset in setting procedure 2.

Set a fixed value for deviation operation.

Setting range: -19999 ~ 29999

CH	No.	Setting procedure	Setting of a fixed value for deviation					
0	1	7						

- The decimal point position is determined by the range code or it is set to the same position as in the lower-limit value of linear scaling.

- Proceed to the next setting procedure by pressing ENT key.

□ "Range code" setting procedure 8

◆ PV bias value setting

This PV bias setting item is provided to display and record a value obtained by adding a set point to or subtracting it from an input value as a PV. A deviation of PV values of a thermocouple or other sensors due to a secular change can be corrected.

Setting range: -19999 ~ 29999

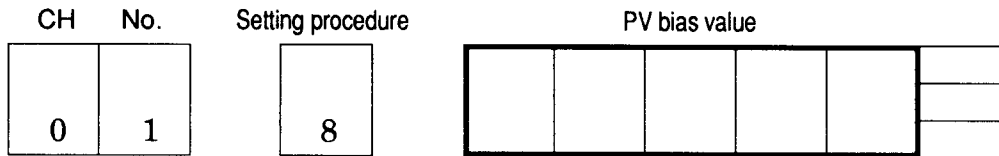

Caution: When a deviation between channels is selected, a PV bias being set in the reference channel is neglected, and only a PV bias value of the working channel is added.

- By pressing ENT key, setting procedure 1 of range data in channels is selected in case of the 2-pen model, so that the setting of range data about channel 1 is completed.
- For setting range data of the next channel, repeat setting procedures 1 ~ 8.

7-6 Recording Scale Setting

■ "SCALE" selection

Select "SCALE" by pressing DATA SET key.

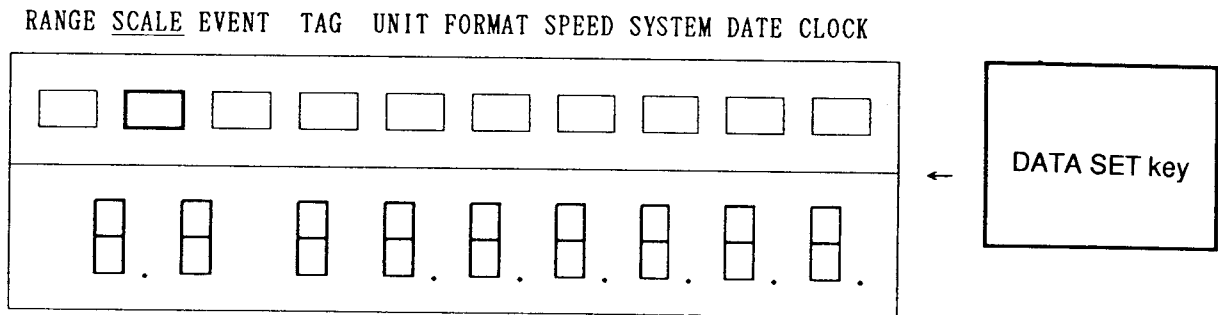

The LED lights at the selected item.

- A recording scale is set by repeating setting procedures 1 ~ 7 every channel.

Setting procedure 1: Setting of the lower-limit (0% value) of recording scale 1

Setting procedure 2: Setting of the higher-limit (100% value) of recording scale 1

Setting procedure 3: Setting of the lower-limit (0% value) of recording scale 2

Setting procedure 4: Setting of the higher-limit (100% value) of recording scale 2

Setting procedure 5: Setting of scale printing ON/OFF scale switching system

Setting procedure 6: Set point for automatic switching of the scale

Setting procedure 7: A differential value for automatic switching of scale

- Set a desired channel No. Assume that CH No. = 01 is set as an example.

Set 01 by ten keys after shifting the cursor to the CH No. indicating position by ← → keys. (The corresponding numeric flickers at the cursor position.) After this setting, the cursor shifts to the next setting item automatically.

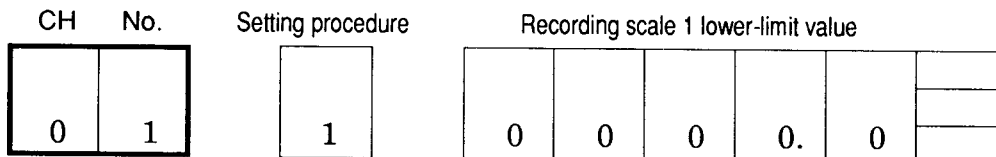

"SCALE" setting procedure 1

◆ Setting of the lower-limit (0% value) of recording scale 1

This item is provided to determine the lower-limit of No. 1 scale to be recorded in trend recording mode.
This setting can be done irrespective of input measuring ranges.

Setting range: -19999 ~ 29999

- The decimal point position is determined by a range code or it is set to the same position as in the lower-limit value of linear scaling.

CH	No.	Setting procedure	Lower-limit (0% value) of recording scale 1																		
0	1	1	<table border="1" style="display: inline-table; border-collapse: collapse;"> <tr><td style="width: 20px; height: 20px;"></td><td style="width: 20px; height: 20px;"></td><td style="width: 20px; height: 20px;"></td><td style="width: 20px; height: 20px;"></td><td style="width: 20px; height: 20px;"></td><td style="width: 20px; height: 20px;"></td></tr> <tr><td style="width: 20px; height: 20px;"></td><td style="width: 20px; height: 20px;"></td><td style="width: 20px; height: 20px;"></td><td style="width: 20px; height: 20px;"></td><td style="width: 20px; height: 20px;"></td><td style="width: 20px; height: 20px;"></td></tr> <tr><td style="width: 20px; height: 20px;"></td><td style="width: 20px; height: 20px;"></td><td style="width: 20px; height: 20px;"></td><td style="width: 20px; height: 20px;"></td><td style="width: 20px; height: 20px;"></td><td style="width: 20px; height: 20px;"></td></tr> </table>																		

- Proceed to the next setting procedure by pressing ENT key.

□ "SCALE" setting procedure 2

◆ Setting of the higher-limit (100% value) of recording scale 1

This item is provided to determine the higher-limit of No. 1 scale to be recorded in trend recording mode. This setting can be done irrespective of input measuring ranges.

Setting range: -19999 ~ 29999

- The decimal point position is determined by a range code or it is set to the same position as in the lower-limit value of linear scaling.

CH	No.	Setting procedure	Higher-limit (100% value) of recording scale 1																		
0	1	2	<table border="1"> <tr><td></td><td></td><td></td><td></td><td></td><td></td></tr> <tr><td></td><td></td><td></td><td></td><td></td><td></td></tr> <tr><td></td><td></td><td></td><td></td><td></td><td></td></tr> </table>																		

- Proceed to the next setting procedure by pressing ENT key.

□ "SCALE" setting procedure 3

◆ Setting of the lower-limit (0% value) of recording scale 2

This item is provided to determine the lower-limit of No. 2 scale to be recorded in trend recording mode.
This setting can be done irrespective of input measuring ranges.

Setting range: -19999 ~ 29999

- The decimal point position is determined by a range code or it is set to the same position as in the lower-limit value of linear scaling.

CH	No.	Setting procedure	Lower-limit (0% value) of recording scale 2																		
0	1	3	<table border="1" style="display: inline-table; vertical-align: middle;"> <tr><td> </td><td> </td><td> </td><td> </td><td> </td><td> </td></tr> <tr><td> </td><td> </td><td> </td><td> </td><td> </td><td> </td></tr> <tr><td> </td><td> </td><td> </td><td> </td><td> </td><td> </td></tr> </table>																		

- Proceed to the next setting procedure by pressing ENT key.

□ "SCALE" setting procedure 4

◆ Setting of the higher-limit (100% value) of recording scale 2

This item is provided to determine the higher-limit of No. 2 scale to be recorded in trend recording mode.
This setting can be done irrespective of input measuring ranges.

Setting range: -19999 ~ 29999

- The decimal point position is determined by a range code or it is set to the same position as in the lower-limit value of linear scaling.

CH	No.	Setting procedure	Higher-limit (100% value) of recording scale 2																		
0	1	4	<table border="1" style="display: inline-table; vertical-align: middle;"> <tr><td> </td><td> </td><td> </td><td> </td><td> </td><td> </td></tr> <tr><td> </td><td> </td><td> </td><td> </td><td> </td><td> </td></tr> <tr><td> </td><td> </td><td> </td><td> </td><td> </td><td> </td></tr> </table>																		

- Proceed to the next setting procedure by pressing ENT key.

□ "SCALE" setting procedure 5

Setting of scale printing ON/OFF and scale switching system

◆ Set ON (printed) or OFF (not printed) in scale printing.

- | | |
|------------------------------------|---------------------------------|
| 1: Recording scale 1 — Not printed | Recording scale 2 — Not printed |
| 2: Recording scale 1 — Printed | Recording scale 2 — Not printed |
| 3: Recording scale 1 — Not printed | Recording scale 2 — Printed |
| 4: Recording scale 1 — Printed | Recording scale 2 — Printed |

CH	No.	Setting procedure	Printing of recording scale
0	1	5	<input type="checkbox"/> <input type="checkbox"/> <input type="checkbox"/> <input type="checkbox"/> <input type="checkbox"/> <input type="checkbox"/>

Example) Assume that recording scales 1 and 2 are printed.

CH	No.	Setting procedure	Printing of recording scale
0	1	5	<input checked="" type="checkbox"/> <input type="checkbox"/> <input type="checkbox"/> <input type="checkbox"/> <input type="checkbox"/> <input type="checkbox"/>

◆ Recording scale switching system

- 1: Not switched
- 2: Automatic switching — The recording scale is switched automatically according to the set points in setting procedure 6.
- 3: External contact input switching — The recording scale is switched according to an external contact input (additional specifications).

CH	No.	Setting procedure	Switching system of recording scale
0	1	5	<input type="checkbox"/> <input type="checkbox"/> <input checked="" type="checkbox"/> <input type="checkbox"/> <input type="checkbox"/> <input type="checkbox"/>

Example) Assume that the automatic switching is selected.

CH	No.	Setting procedure	Switching system of recording scale
0	1	5	<input type="checkbox"/> <input type="checkbox"/> <input checked="" type="checkbox"/> <input type="checkbox"/> <input type="checkbox"/> <input type="checkbox"/>

● Proceed to the next setting procedure by pressing ENT key.

If the automatic switching in 2 is selected, the setting procedure proceeds to setting item 6.
In other cases, the recording scale setting in one channel ends now.

□ "SCALE" setting procedure 6

◆ Setting of the automatic switching point of recording scale

This setting procedure is skipped when those other than 2 "Automatic switching system" is selected in setting procedure 5.

Setting range: -19999 ~ 29999

CH	No.	Setting procedure	Automatic switching point of recording scale
0	1	6	

- Proceed to the next setting procedure by pressing ENT key.

□ "SCALE" setting procedure 7

◆ Setting of a differential value in recording scale switching

This setting procedure is skipped when a system other than 2 "Automatic switching system" is selected in setting procedure 5.

A differential value is set to offer an allowance so that the recording scale does not return as before soon in case of automatic switching.

Setting range: 0 ~ 29999

CH	No.	Setting procedure	Setting of a differential value in recording scale switching																		
0	1	7	<table border="1" style="display: inline-table; vertical-align: middle;"> <tr><td> </td><td> </td><td> </td><td> </td><td> </td><td> </td></tr> <tr><td> </td><td> </td><td> </td><td> </td><td> </td><td> </td></tr> <tr><td> </td><td> </td><td> </td><td> </td><td> </td><td> </td></tr> </table>																		

Example) Assume that the differential value in recording scale switching is set to 50°C.

CH	No.	Setting procedure	Setting of the differential value in recording scale switching																		
0	1	7	<table border="1" style="display: inline-table; vertical-align: middle;"> <tr><td> </td><td> </td><td> </td><td>5</td><td>0</td><td> </td></tr> <tr><td> </td><td> </td><td> </td><td> </td><td> </td><td> </td></tr> <tr><td> </td><td> </td><td> </td><td> </td><td> </td><td> </td></tr> </table>				5	0													
			5	0																	

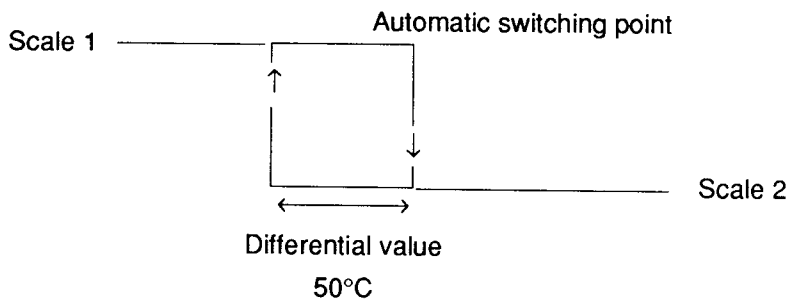

● By pressing ENT key, the recording scale setting ends in case of a 1-channel input.

In case of a 2-channel input, setting procedure 1 of recording scale 2 is selected. Repeat setting procedures 1 ~ 7.

7-7 Event Setting

■ "EVENT" selection

Select "EVENT" by pressing DATA SET key.

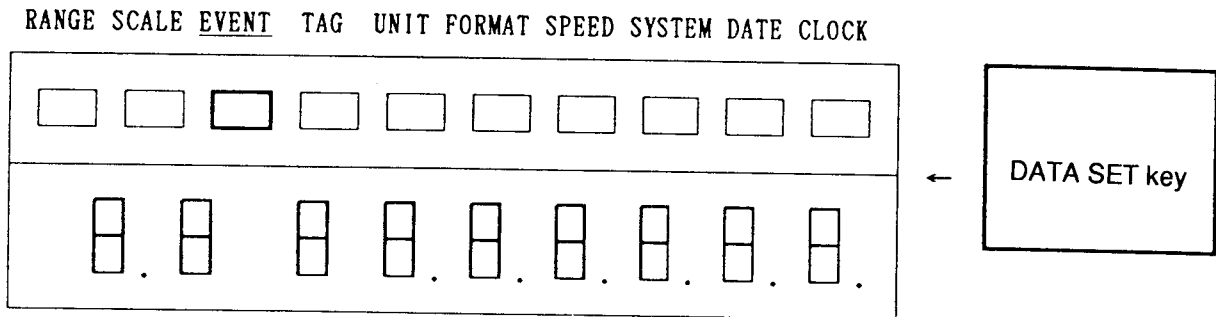

The LED lights at the selected item.

- This event setting is provided to set the event type, higher-limit alarm, lower-limit alarm, and working relay No. every input channel by repeating setting procedures 1 ~ C. Max. 4 events can be set every channel.

- Setting procedure 1: 1st event type setting
- Setting procedure 2: 2nd event type setting
- Setting procedure 3: 3rd event type setting
- Setting procedure 4: 4th event type setting
- Setting procedure 5: 1st event set point setting
- Setting procedure 6: 2nd event set point setting
- Setting procedure 7: 3rd event set point setting
- Setting procedure 8: 4th event set point setting
- Setting procedure 9: 1st event differential value setting
- Setting procedure A: 2nd event differential value setting
- Setting procedure B: 3rd event differential value setting
- Setting procedure C: 4th event differential value setting

- Set a desired channel No. Assume that CH No. = 01 is set as an example.
Set 01 by ten keys after shifting the cursor to the CH No. indicating position by ← → keys. (The corresponding numeric flickers at the cursor position.) After this setting, the cursor shifts to the next setting item automatically.

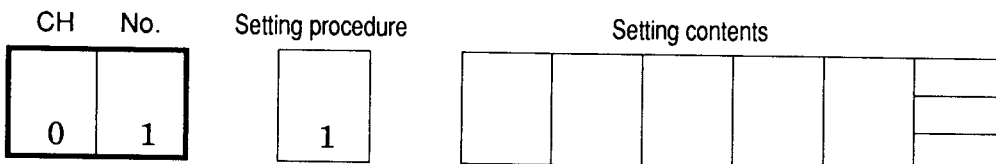

□ "EVENT" setting procedures 1 ~ C

◆ Event type setting

Four event types can be set every channel.

Setting contents: H : Higher limit (Press "SHIFT" + "HI/7" keys.)
 L : Lower limit (Press "SHIFT" + "LO/8" keys.)
 —: OFF ("SHIFT" + "OFF/9" keys.)

CH	No.	Setting procedure	Event type
0	1	1	H

◆ Relay No. setting

An output can be taken by a corresponding relay every event point. Set a desired relay No.

Setting contents: Relay N. 0 ~ 6

CH	No.	Setting procedure	Relay No.
0	1	1	H 1

Caution:

- No relay No. can be set in a model where no event output (additional specifications) is provided.
- No relay output is taken, if relay No.=0 is set.
- If event type : OFF is selected, this setting cannot be done.

● Proceed to the next setting procedure by pressing ENT key.

Setting procedures 2 ~ 4 can also be set by the same operation as described above.

◆ Event set point setting

Set a set point corresponding to the event type (H: higher-limit or L: lower-limit) being set in setting procedures 1 ~ 4. This setting procedure is skipped to the next one, if event type OFF is selected.

Setting contents: -19999 ~ +29999

CH	No.	Setting procedure	Event set point
0	1	5	5 0 0 0

Caution: The decimal point position is determined by the range code or it is set to the same position as preset in the lower-limit value setting of linear scaling (engineering range) in case of a linear input.

● Proceed to the next setting procedure by pressing ENT key.

Perform setting procedures 6 ~ 8 in the same way as described above.

◆ Event differential value setting

Set a differential value (differential gap) from an event set point being set in setting procedures 5 ~ 8. This setting procedure is skipped to the next one, if event type OFF selected.

Setting contents: 0 ~ 29999

CH	No.	Setting procedure	Event differential value						
0	1	9				1	0		

Caution: The decimal point position is determined by the range code or it is set to the same position as preset in the lower-limit value setting of linear scaling (engineering range) in case of a linear input.

● Proceed to the next setting procedure A by pressing ENT key.

Perform setting procedures A ~ C in the same way as described above. By pressing ENT key after setting procedure C, event setting procedure 2 of 2 channels is selected in case of the 2-pen model or the event setting ends in case of the 1-pen model.

7-8 Tag Name Setting

■ "TAG" selection

Select "TAG" by pressing DATA SET key.

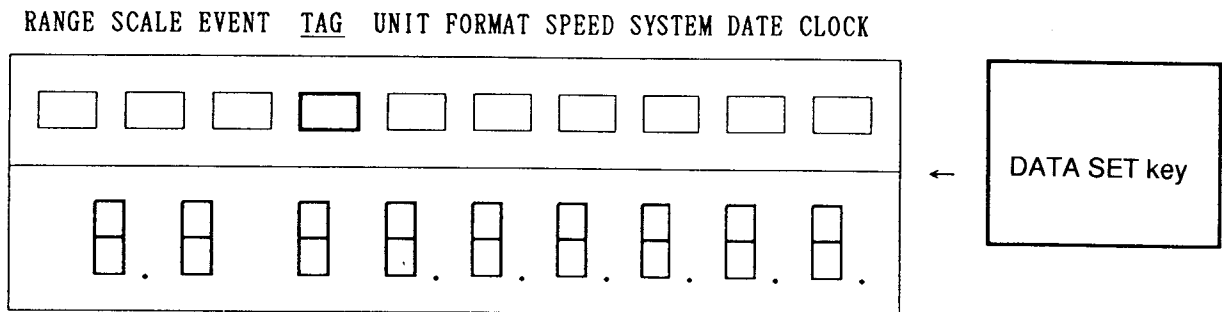

The LED lights at the selected item.

- An intrinsic name (Tag name: Max. 8 characters) can be designated to each channel in tag name setting. For this setting, set max. 8 characters in hexadecimal data to setting procedures 1 ~ 8 one by one in each channel.

Setting procedure 1: 1st character setting

Setting procedure 2: 2nd character setting

Setting procedure 3: 3rd character setting

Setting procedure 4: 4th character setting

Setting procedure 5: 5th character setting

Setting procedure 6: 6th character setting

Setting procedure 7: 7th character setting

Setting procedure 8: 8th character setting

- Set a desired channel No. Assume that CH No. = 01 is set as an example.

Set 01 by ten keys after shifting the cursor to the CH No. indicating position by ← → keys. (The corresponding numeric flickers at the cursor position.) After this setting, the cursor shifts to the next setting item automatically.

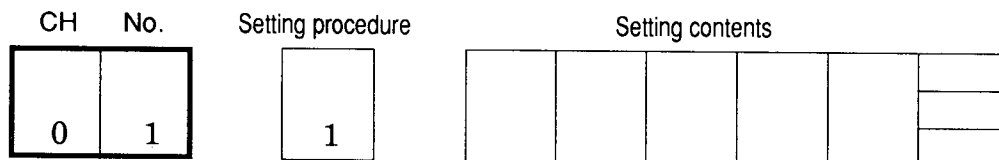

□ "Tag name" setting procedure 1 ~ 8

◆ Tag name setting

Setting contents: Max. 8 characters specified by the character codes on the next page every channel

CH	No.	Setting procedure	Character code setting			
0	1	1	5	4		

- Proceed to the next setting procedure by pressing ENT key. Perform setting procedures 2 ~ 8 in the same way to set all 8 characters.

By pressing ENT key after setting procedure C, tag setting procedure of channel 2 is selected in case of the 2-pen model, or the tag setting ends in case of the 1-pen model.

Caution: If no tag name is written, perform this setting work up to setting procedure 8 after setting the character code to [20] (Blank).

Character Codes Table

Lower-significant digit 0 1 2 3 4 5 6 7 8 9 A B C D E F

Higher-significant digit

2		!	ˆ	#	\$	%	&	'	()	*	+	,	-	.	/
3	0	1	2	3	4	5	6	7	8	9	:	;	<	=	>	?
4	0	A	B	C	D	E	F	G	H	I	J	K	L	M	N	O
5	P	Q	R	S	T	U	V	W	X	Y	Z	[¥]	^	-
6	ˆ	a	b	c	d	e	f	g	h	i	j	k	l	m	n	o
7	p	q	r	s	t	u	v	w	x	y	z	Ω	∅	μ	2	2
8	3	°	◦	.												

© Setting example: Set tag name TIC-001 to channel 1.

Setting procedure	Tag name	Character code
1	T	54
2	I	49
3	C	43
4	—	2D
5	0	30
6	0	30
7	1	31
8	(Blank)	20

7-9 Engineering Unit Setting

■ "UNIT" selection

Select "UNIT" by pressing DATA SET key.

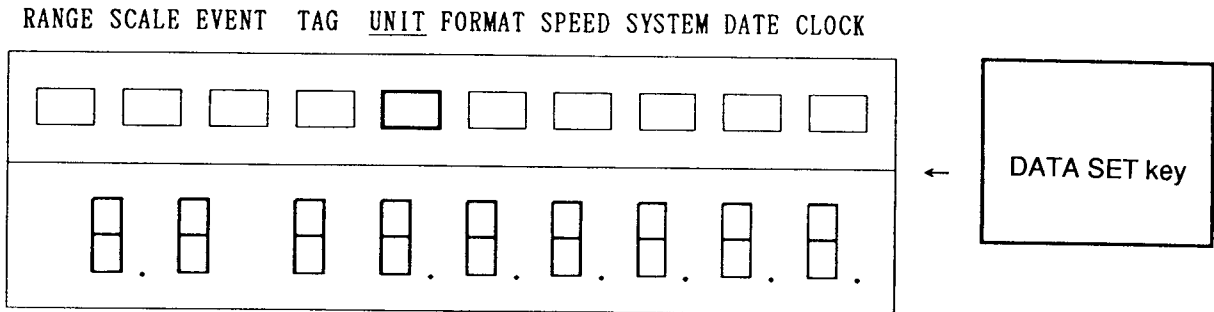

The LED lights at the selected item.

- An intrinsic unit (Unit name: Max. 6 characters) can be designated to a linear scaling (voltage, current) input every channel. Set max. 6 characters by hexadecimal data to setting procedures 1 ~ 6 every channel.

Setting procedure 1: 1st character setting

Setting procedure 2: 2nd character setting

Setting procedure 3: 3rd character setting

Setting procedure 4: 4th character setting

Setting procedure 5: 5th character setting

Setting procedure 6: 6th character setting

- Set a desired channel No. Assume that CH No. = 01 is set as an example.

Set 01 by ten keys after shifting the cursor to the CH No. indicating position by ← → keys. (The corresponding numeric flickers at the cursor position.) After this setting, the cursor shifts to the next setting item automatically.

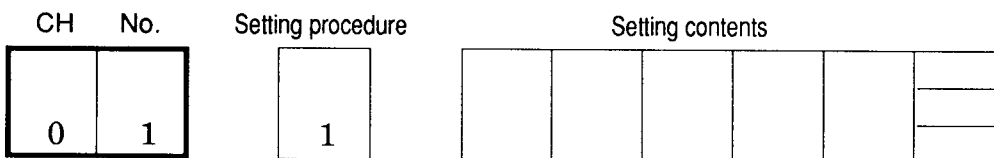

□ "Engineering unit" setting procedure 1 ~ 6

◆ Unit setting

Setting contents: Max. 6 characters specified by character codes on the next page can be set every channel.

CH	No.	Setting procedure	Unit setting							
0	1	1	6	B						

- Proceed to the next setting procedure 2 by pressing ENT key. Perform setting procedures 2 ~ 6 in the same way to set all 8 characters.

When ENT key is pressed after setting procedure 6, setting procedure 1 in unit setting of channel 2 is selected in case of the 2-pen model, or the unit setting ends in case of the 1-pen model.

Caution: If no unit is written, perform this setting work up to setting procedure 8 after setting the character code to [20] (Blank).
 This engineering unit setting is effective for linear scaling (voltage, current input) only. In case of a thermocouple input or a resistance thermometer input, °C or °F is automatically selected, and this setting item is skipped.

Character Codes Table

Lower-significant digit	0	1	2	3	4	5	6	7	8	9	A	B	C	D	E	F
Higher-significant digit																
2		!	"	#	\$	%	&	'	()	*	+	,	-	.	/
3	0	1	2	3	4	5	6	7	8	9	:	;	<	=	>	?
4	0	A	B	C	D	E	F	G	H	I	J	K	L	M	N	O
5	P	Q	R	S	T	U	V	W	X	Y	Z	{	¥	}	~	-
6	~	a	b	c	d	e	f	g	h	i	j	k	l	m	n	o
7	p	q	r	s	t	u	v	w	x	y	z	Ω	∅	μ	2	2
8	3	°	°	.												

© Setting example: Assume that engineering unit Kg/cm² is set to channel 1.

Setting procedure	Tag name	Character code
1	K	6B
2	g	67
3	/	2F
4	c	63
5	m	6D
6	2	7E

7-10 Selection of Recording Formats and Phase Synchronizing Methods

■ "Recording format" selection

Select "FORMAT" by pressing DATA SET key.

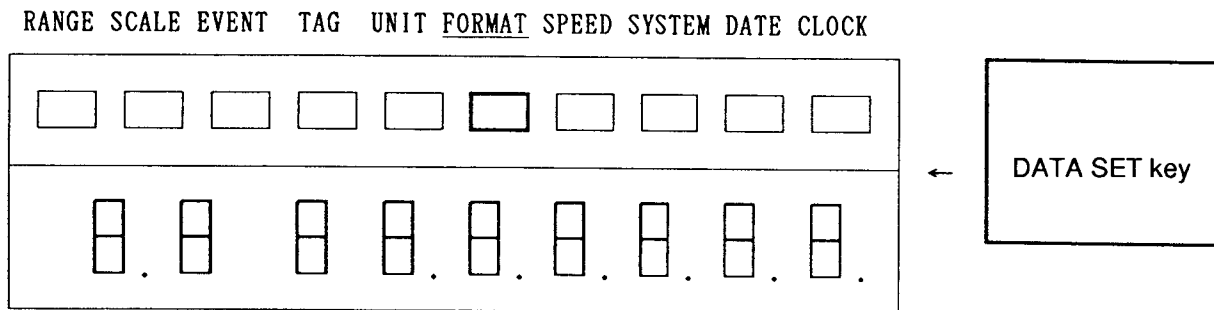

The LED lights at the selected item.

- Select one of three kinds of recording formats.
This common setting item is irrespective of channels.
- The phase synchronization is effective for the 2-pen model only, and it compensates for a deviation of the time axis between pen No. 1 and pen No. 2.
DPR500 stores a distance from pen No. 1 (as reference pen) to pen No. 2 into memory, and records data on the chart when data have been sent by the distance so as to compensate for the deviation of the time axis; provided that the storage is restricted as follows.

An input value is stored into memory as it is when the chart speed is higher than 12.5mm.

An average value of two-times input data having a measuring cycle of 125msec is stored into memory when the chart speed is 10mm.

An average value of three-times input data having a measuring cycle of 125msec is stored into memory when the chart speed is 5mm.

"Recording formats" selection

- Setting contents: 1 : Trend recording (Analog recording)
 Time and scale are printed to conventional trend recording.
- 2 : Trend + tabular recording (Analog + digital recording)
 Tabular records of PV values are doubly printed to trend recording every 75mm chart feed.
- 3 : Zone recording
 The chart is divided into two parts. Channel-1 inputs are recorded to the left side, while channel-2 inputs are recorded to the right side as trend + tabular recording. When zone recording is set, no scale is switched. Zone recording cannot be set in case of the 1-pen model.

CH	No.	Setting procedure	Recording formats selection					
			2					

"Phase synchronization (POC)" selection

- Setting contents: 1 : No phase synchronization (OFF)
- 2 : Phase synchronization is done (ON)
 In case of the 1-pen model, the phase synchronization setting is skipped without any indication.

CH	No.	Setting procedure	Recording formats selection	Phase synchronization selection			
			2	2			

7-11 Chart Speed Selection

■ "Chart speed" selection

Select "SPEED" by pressing DATA SET key.

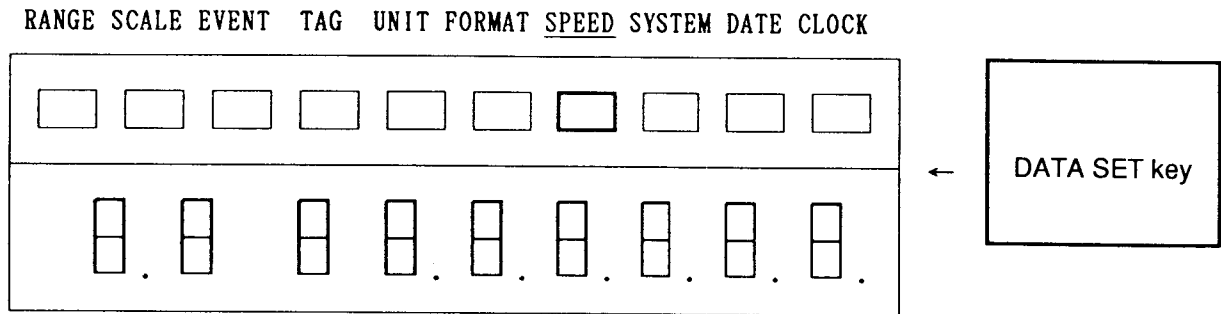

The LED lights at the selected item.

- The chart speed is selected by setting procedures 1 ~ 2 in common setting item.

Setting procedure 1: Chart speed 1

Setting procedure 2: Chart speed 2

When a model is not provided with an external contact input option, setting of chart speed 2 is skipped.

□ "SPEED" setting procedure

Select a chart speed out of 16 speeds shown below.

Selection number	Contents
01 :	5mm/h
02 :	10mm/h
03 :	12.5mm/h
04 :	25mm/h
05 :	50mm/h
06 :	75mm/h
07 :	100mm/h
08 :	150mm/h
09 :	300mm/h
10 :	600mm/h
11 :	750mm/h
12 :	1500mm/h
13 :	3000mm/h
14 :	4500mm/h
15 :	6000mm/h
16 :	9000mm/h

◆ Chart speed 1 selection

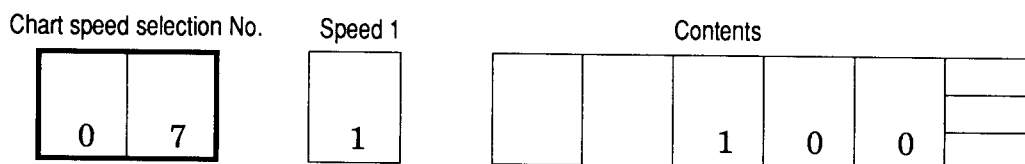

Select a necessary chart speed by selection numbers.

- By pressing ENT key, the operation proceeds to the chart speed selection in setting procedure 2.

◆ Chart speed 2 selection

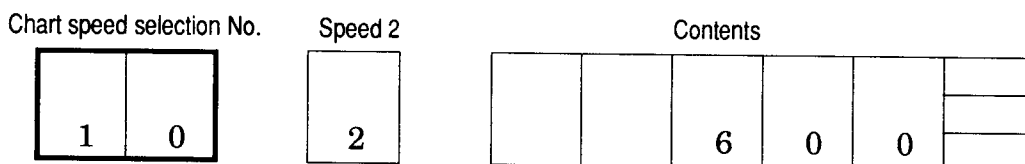

Select a necessary chart speed by selection numbers.

When a model is not provided with an external contact input option, setting of chart speed 2 is skipped.

- By pressing ENT key, the operation returns to setting procedure 1.

7-12 Keylock Levels and Communication Conditions Setting

■ "SYSTEM" selection

Select "SYSTEM" by pressing DATA SET key.

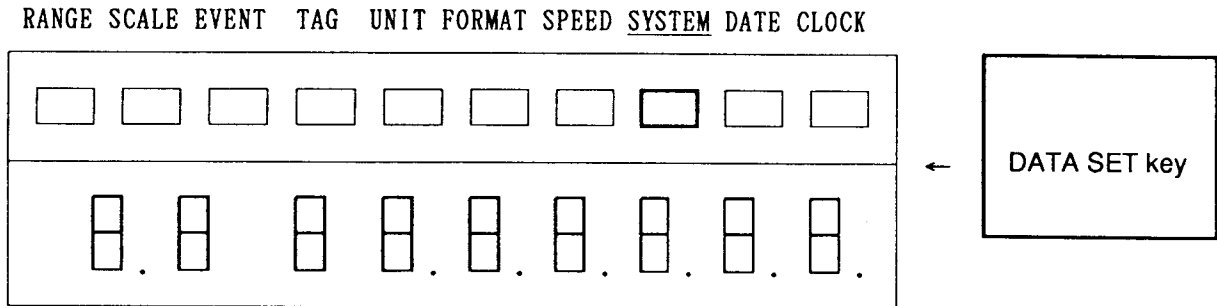

The LED lights at the selected item.

- In "SYSTEM", the keylock levels and communication conditions are set.
- Keylock is done for the purpose of preventing wrong setting, wrong change, or wrong operation in the configuration mode and operation mode. Three keylock levels are provided. Select a necessary range. Whether keylock is done or not can be set by KEYLOCK key on the front panel.
- Set the following communication conditions.
 - Communication access right
 - Communication addresses
 - Baud rate
 - Bit length
 - Parity
 - Stop bit

These communication conditions can be set only when the model is provided with a communication option.

□ "SYSTEM" setting procedure

◆ Keylock level: Setting procedure 1

The keylock levels can be set in the following 3 stages.

Setting contents:

Level	Locked function	Operable keys
1	Data setting, recording operation	DISPLAY, ←, →
2	Data setting	DISPLAY, ←, →, SHIFT, MSG/DMD, LIST, BACK/FEED, and REC
3	A part of data setting	DISPLAY, ←, →, EVENT, FORMAT, and SPEED of DATA SET keys

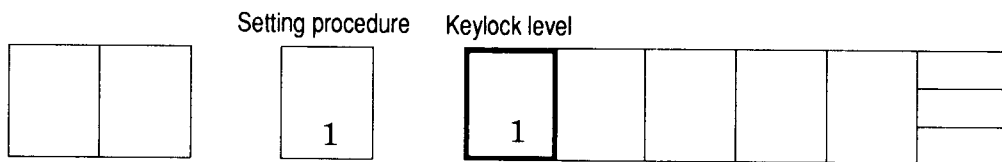

- Proceed to the next setting procedure 2 by pressing ENT key. If no communication option is added, setting of communication conditions is skipped, and no indication is done.

◆ Setting of communication conditions: Setting procedures 2 ~ 4

Setting contents: Communication access right, communication addresses; Setting procedure 2

- Communication access right; 1 : Communication disable
 2 : READ only enable
 3 : READ/WRITE enable

Communication addresses; 00 ~ 7FH (Communication addresses defined by the CP system communication regulations)
 If 00 is set as a communication address, the communication is disable.

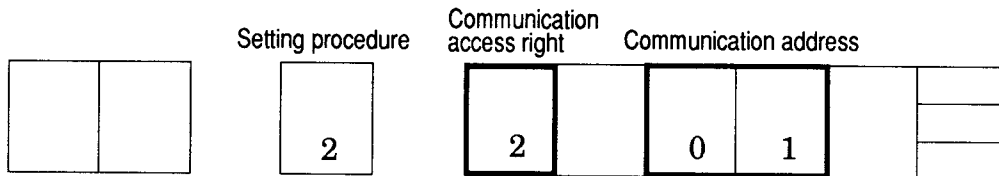

Setting contents: Baud rate ; Setting procedure 3

This setting procedure is skipped if the communication access is disable.

- 1 : 1200bps
 2 : 2400bps
 3 : 4800bps
 4 : 9600pbs

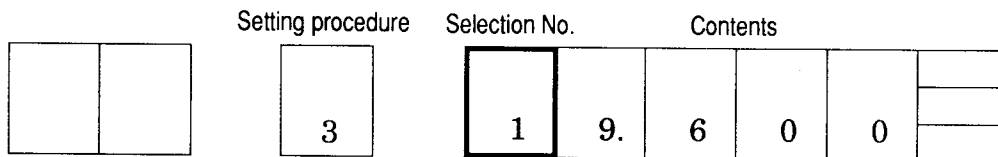

Setting contents: Bit length, Parity bit, Stop bit ; Setting procedure 4

This setting procedure is skipped if the communication access is disable.

- Bit length; 1 : 7-bit length
 2 : 8-bit length
 Parity bit ; 1 : No parity
 2 : Even parity
 Stop bit ; 1 : 1 bit
 2 : 2 bits

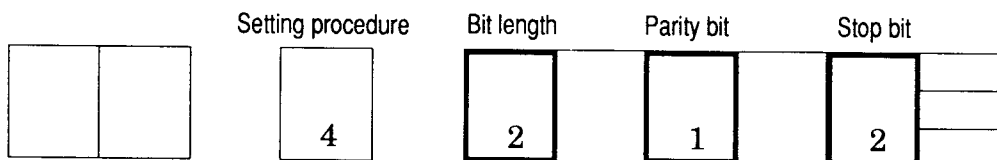

7-13 Setting of Date (Year, Month, and Day)

■ "DATE" selection

Select "DATE" by pressing DATA SET key.

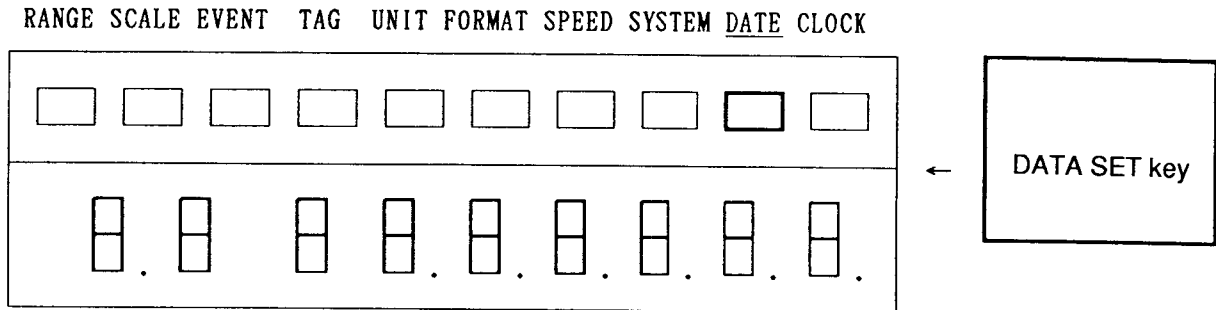

The LED lights at the selected item.

- In DATE, set year, month, and day.
- "Year" setting
Set a year by lower significant 2 digits of year.
- "Month" setting
Set a month by 01 ~ 12.
- "Day" setting
Set a day by 01 ~ 31.
- By loading setting data, the cursor shifts automatically to the next data setting position.
For changing the setting contents, reset them after shifting the cursor to the next data setting position by ← → keys.
- Set and enter the DATE by ENT key.
Example: Nov. 1, 1991

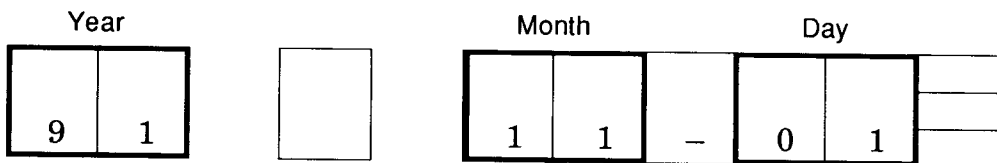

7-14 Setting of Time

■ "CLOCK" selection

Select "CLOCK" by pressing DATA SET key.

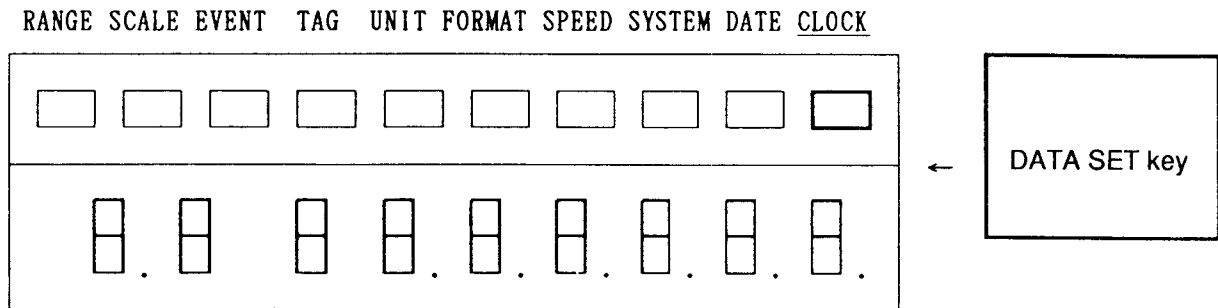

The LED lights at the selected item.

- In CLOCK, set the time.
- "Hour" setting
Set an hour by 24-hours' system.
- "Minute" setting
Set a minute by 01 ~ 59.
- By loading setting data, the cursor shifts automatically to the next data setting position.
For changing the setting contents, reset them after shifting the cursor to the next data setting position by ← → keys.
- Set and enter the time by ENT key.
Example) 14 hours 35 min.

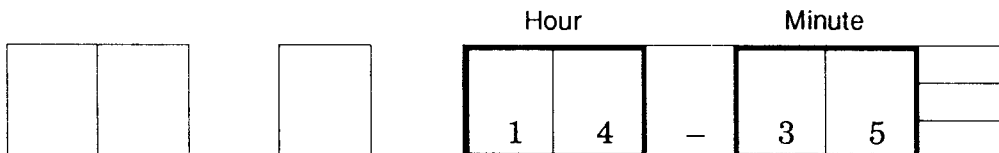

Chapter 8 OPERATION

8-1 Turning on the Power Supply

When no power is applied to the instrument, draw out the main body, and turn ON the POWER switch mounted on the right side panel by setting it upward.

When power is applied, DPR500 performs internal check and pen position check for about 30 seconds before entering its normal operation. All LEDs light during internal check.

8-2 Pen Lifter Operation

The pen lifter is mounted at the lower right part of RCD key. Set this pen lifter downward, if the pen does not lower. This pen lifter is automatically set to the pen-up position when the chart cassette is loaded or unloaded for replacing the chart, etc.

8-3 Recording Start/Stop

Recording is started or stopped by RCD key.

By pressing this key, recording is started or stopped alternately and repeatedly.

The start/stop condition can be confirmed by the lighting or extinction of the RECORD LED on the status indicator.

When recording is started, the year (lower significant digits of a year), month, day, time (hour, minute), and "REC ON" are printed.

The pen is relocated to the position corresponding to a PV value from the left fixed position.

After recording has stopped, the pen returns to the left fixed position. Lift up the pen lift once, if it is not desired to record data carelessly.

Data are resettable even if the recording operation is in progress.

The recording start/stop condition is stored into DPR500 memory even if power is turned OFF, so that it returns to the same condition when turning ON the power supply next.

8-4 Forward Feed and Backward Feed of Chart

These operation cannot be done during the recording or list printing.

(1) Forward feed of chart

The chart continues feeding forward when BACK/FEED key is being pressed. The chart stops feeding when releasing this key.

(2) Backward feed of chart

After making sure that the LED is lit by pressing SHIFT key, press BACK/FEED key. The chart continues feeding backward when BACK/FEED key is being pressed under this condition. The chart stops feeding when releasing the key.

For feeding the chart backward again, repeat the above operation.

Don't feed any chart backward more than necessary for the purpose of preventing careless roll of the chart.

8-5 List Printing

Preset configuration data are printed.

This list printing can be done during recording stop only.

(1) Start of list printing

Press LIST key.

(2) Halfway stop of list printing

For stopping the list printing halfway, press LIST key again.

8-6 Demand Printing

Tabular recording can be done during recording operation.

(1) Press MSG/DMD key. The "RECORD" LED flickers to indicate that the demand recording has been requested.

(2) Demand recording is started about 10 seconds after the "RECORD" LED has started flickering.

The next demand request cannot be done during the flickering of the "RECORD" LED.

(3) No demand request can be cancelled.

(4) Demand printing is done by the following contents.

Year (lower significant digits of year), month, day, time (hour, minute), channel No., event occurrence condition, PV value, and unit.

8-7 User Message Printing

A user message can be printed during recording stop.

(1) Printing method

Press SHIFT key, and make sure that the "SHIFT" LED lights.

Press MSG/DMD key. Input the characters, symbols, and/or numerics specified by the character codes table as a 2-digit character consisting of the higher significant digit and the lower-significant digit every character under this condition, and press ENT key.

These characters are printed one by one.

(2) For inputting A ~ F out of the character codes table, press "1" ~ "6" keys after pressing SHIFT key.

(3) Method of relocating the head to an optional position

The printing head can be relocated to an optional position in case of user message printing.

Input the following control codes instead of characters.

[09] : The head moves rightward by the distance corresponding to 8 characters from the extreme left end. (HT code)

[0A] : The chart is fed by one line after moving to the extreme left end. (LF code)

[0B] : The head moves to the extreme left end. (HM code)

[0C] : The head moves to the extreme left end after feeding the chart by one line. (CL code)

[0D] : No action is done. (CR code)

[1C] : The head is fed rightward by one character. (→ code)

[1D] : The head is fed leftward by one character. (← code)

[1E] : The chart is fed by one. (↑ code)

[1F] : The chart is fed backward by one line. (↓ code)

(4) Return to the original condition

The instrument is reset to the original condition by pressing SHIFT + MSG • DMD or MSG/DMD key.

8-8 Display Selection

The display of the following four modes can be selected by pressing DISPLAY key.

(1) "AUTO" mode

CH No., event condition, PV value, and unit are displayed repeatedly at intervals of 4 seconds.

This display is skipped in a channel where the recording mode is set to OFF.

If all recording modes are set to OFF, "-" is displayed at all digits.

If high and low events occur concurrently in the same channel, the event display "∇" appears.

The decimal point at the most significant digit lights when the phase synchronization (POC) is turned ON.

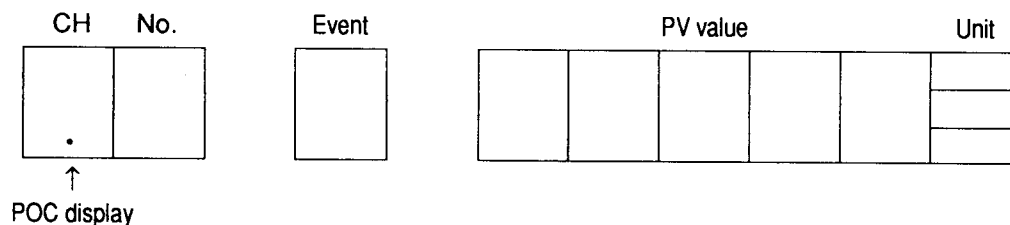

(2) "MAN" mode

A specified CH is displayed continuously. The CH is changed by ← → keys.

(3) "DATE" mode

The date (year, month, day) is displayed. A year is displayed by lower significant 2 digits of the year.

(4) "CLOCK" mode

Hour and minute are displayed. The "-" between hour and minute flickers once every second.

8-9 Event Occurrence Display

When an event occurs, "EVENT" LED lights. If "AUTO" or "MAN" mode is selected, the status is displayed when the event CH is displayed.

Example) An H (high) event occurs in CH 1.

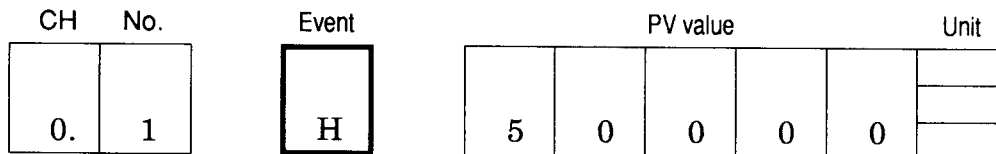

8-10 Keylock

By pressing KEYLOCK key, the instrument is locked to the keylock level being preset in the configuration. For unlock, continue pressing the KEYLOCK key again for longer than 3 seconds. The LED goes out when the keylock is released.

8-11 "CAL" Key Mode

This key is used by a Yamatake-Honeywell's service engineer for various adjustment services to DPR500. This key is not used usually. Don't touch this key usually, although no reaction occurs even if this key is pressed.

8-12 Operation of Wire Dot Printer during Recording

The wire dot printer reciprocates rightward and leftward once every 10 to 20 seconds for the purpose of keeping track of the pen position accurately during the recording action.

8-13 Chart Speed-to-Printing Relation

All printing is done at a chart speed of 5 ~ 1500mm/h. However, a time marker only is printed at higher than 3000mm/h in all recording other than trend recording.

Chapter 9 TROUBLESHOOTING

When DPR500 does not function normally, it is not always caused by a trouble, but it may be caused by mishandling or misoperation. If DPR500 does not function normally, check it according to the following troubleshooting flow to make sure whether it is defective or not.

If DPR500 cannot be recovered to its normal conditions after the following check, please contact your nearest Yamatake-Honeywell's sales agent.

9-1 Neither Display nor Recording is Done.

- ↓
- Power wiring is wrong. YES → Connect the power line correctly
↓ NO
- Power voltage is not correct. YES → Feed the correct power supply.
↓ NO
- The fuse is blown out. YES → After eliminating the cause of the blown-out failure, replace the fuse.
↓ NO
- Power connector is disconnected in the case. YES → Connect the power connector correctly.
↓ NO

DPR500 may be defective. Please contact your nearest sales agent.

9-2 Abnormal Display

- ↓
- An error display appears. YES → Error 06 (Pen or wire dot is caught by the chart.) YES → After eliminating the cause of the failure, turn on the power supply again.
↓ NO ↓ NO
Error 09 YES → Check the ambient temperature.
- An OL display appears. YES → A burnout display
Check the input for disconnection, short-circuit failure, and other defects.
↓ NO ↓ NO No or if the error display does not disappear after the above processing.

Please contact your nearest sales agent.

- Wrong setting YES → Set the instrument correctly.
↓ NO
- External strong noises are introduced. YES → After eliminating noises, turn on the power supply again.
↓ NO
- A wrong input YES → Set the input range correctly to meet actual inputs.
↓ NO
- Sensor is defective. YES → Replace it with normal one.
↓ NO

DPR500 may be defective. Please contact your nearest sales agent.

9-3 The Indicator Indicates Data correctly, but Data are not Recorded correctly.

↓

Recording stop is selected as a recording mode. YES → Set the recording mode correctly.

↓ NO

Record ON/OFF LED does not light. YES → Press RCD key to turn ON the recording.

↓ NO

Pen or ribbon is not set correctly. YES → Set them correctly.

↓ NO

Chart or chart cassette is not set correctly. YES → Set them correctly.

↓ NO

Pen does not lower. YES → Lower the pen by the pen UP/DOWN lever.

↓ NO

Pen or ribbon has reached its lift. YES → Replace it.

↓ NO

DPR500 may be defective. Please contact your nearest sales agent.

9-4 Self-diagnosis and Error Codes Table

DPR500 provides a self-diagnostic function. It checks its functions as occasion demands, and indicates an error code on the indicator, if defective.

If a diagnostic error occurs, DPR500 stops normal display, and continues displaying an error code preferentially until the error is released.

If plural errors occur concurrently, DPR500 indicates an error code having a lower error code number, and also indicates other error codes after the displayed error code has been cancelled.

For cancelling an error code, the power supply must be turned on again in case of certain items.

If an error code has been displayed, check the troubleshooting items, and contact your nearest sales agent, if not recovered.

Error display	Diagnostic contents	Processing
Err01 (ROM diagnosis)	Performs check sum diagnosis every Kbytes.	An error display appears. DPR500 continues functioning as a recorder.
Err02 (EEPROM diagnosis)	Performs verify check when writing data.	An error display appears. DPR500 continues functioning as a recorder.
Err03 (RAM diagnosis)	Checks if correct values can be written every certain range.	An error display appears. DPR500 continues functioning as a recorder.
Err04 (RTC diagnosis)	Performs busy flag check about the clock LSI.	An error display appears. DPR500 continues functioning as a recorder.
Err05 (Pen position diagnosis)	Checks if the pen is positioned normally	
Err06 (Printer diagnosis)	Checks the zero position of the printer head.	An error display appears. Printing action stops. All action other than printing action is continued.
Err08 (Auto zero input diagnosis)		
Err09 (Reference junction input error diagnosis)	Checks if the reference junction of the thermocouple is within a range of $-30 \sim 80^{\circ}\text{C}$, and displays an error, if not. The error display disappears when the reference junction is recovered to be within the specified range.	DPR500 continues functioning as a recorder even during the error display. In this case, -30°C or 80°C is used as a reference junction input value.
Err10 (Configuration data diagnosis)		

Chapter 10 MAINTENANCE

10-1 Consumables

■ Pen Cartridge

A disposable type

Replace the pen cartridge once every recording length of 2000m or about 2 months.

■ Ink Ribbon Cassette

A disposable type

Replace once every about 6 months in a continuous run.

■ Dry Batteries

Replace once every year or so. (Recommendable period by the dry battery maker)

■ Recording Chart

The chart is about 20m in full length. A red shortage notice mark appears on the right side when the residual quantity of the chart becomes about 1.5m.

■ Chart Illumination Lamp

A cold cathode fluorescent lamp is used as the chart illumination lamp. Unlike general fluorescent lamps, this lamp does not break suddenly. However, the half value period of its brightness is about 20000 hours.

Replace the lamp, referring to this period.

■ Lubrication

DPR500 does not use any part to be lubricated.

If lubricated by mistake, it may cause malfunction. Never lubricate any part of DPR500, accordingly.

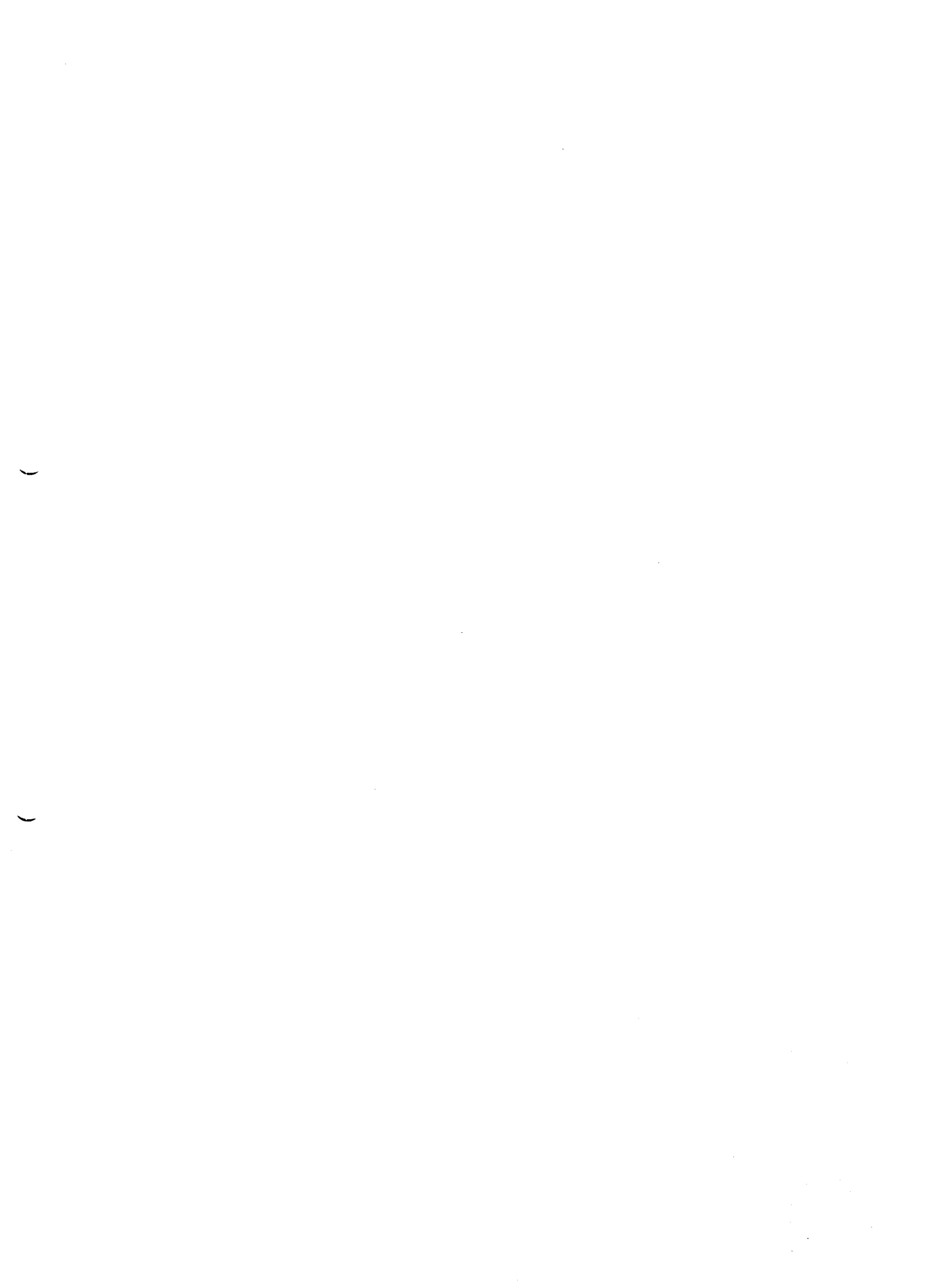

Specifications are subject to change without notice.

Yamatake

Yamatake Co. Ltd.

Control Products Division
29Flr, Landmark Tower
2-2-1-1 Minato Mirai, Nishi-ku
Yokohama, Kanagawa
220-81, Japan
Phone: 81-45-224-1554
Fax: 81-45-224-1568

Savemation

Helping You Control Your World

Printed in Japan. (H)