

# WaterMAG

## Electromagnetic Flowmeter for Water Applications

### Model MCB10A

#### OVERVIEW

The WaterMAG is an electromagnetic flowmeter for water measurement applications based on field proven Yamatake technologies.

The WaterMAG, offers appropriate functions for water applications, thus compact in size and best meets water flow monitoring.



Nominal size: 15 to 100 mm

#### FEATURES

##### **Lowest “Cost of Ownership”**

##### **Energy efficient**

No pressure loss occurs with the electromagnetic flowmeter thus resulting in less energy required for the flow.

##### **Maintenance free**

WaterMAG does not have any moving parts in a flowtube thus resulting in free from maintenance.

##### **Easy operation**

WaterMAG has all necessary functions for water flow monitoring thus resulting in easy operation.

##### **Compact in size and light in weight**

Easy to handle and easy to install.

#### APPLICATIONS

##### **Utility in factories**

Monitoring water consumption in factories.

##### **Monitoring cooling water**

##### **Monitoring filtering water**

**For converter****FUNCTIONAL SPECIFICATIONS****Type of protection**

IEC IP65 (for indoor use only)

**Output signal****Analog output**

4 to 20 mA DC

Load resistance: 0 to 400 Ω

**Pulse output**

Select either pulse output or contact output.

**Pulse output (Totalized value output)**

Open collector

Contact capacitance: 30V DC max., 100 mA max.

Pulse width: 1 ms to 1 s

Adjustable between 1ms to 1s or fixed at 50% of duty.

Pulse frequency: 0.0001 to 500 Hz

**Contact output**

Open collector

Contact capacitance: 30 V DC max., 100mA max.

Alarm for Hi-Lo limit or failure status output

**Flow unit**Volume flow: m<sup>3</sup>, L, cm<sup>3</sup>, G, mG, kG, B (barrel)

Mass flow : t, kg, g, lb.

Time : d, h, m, s

**Display****Display: LCD**

Main display: 7-segment, 8 digits

Sub display: 16 digits, 2 lines

Display contents:

Demonstrates three values simultaneously

% flow rate, Actual flow rate, Totalized value

**Data setting**

Operation by four key switches

**Damping**

Adjustable between 0.5 and 199.9 seconds.

Default setting: 5 seconds

Low flow cutoff

Adjustable between OFF (0%) and 10% of setting range.

Below selected value, output is driven to the zero flow rate signal level.

Default setting: OFF (0%)

**Dropout**

Adjustable between 0 and 10% of setting range.

Below selected value, pulse output is cut.

Default setting: 2%

**Empty pipe detection**

If the detector is empty, analog output and pulse output will be fixed at zero. The display will be latched to zero and "EMPTY" will be indicated.

**Failure diagnostics**

If the converter malfunctions, the analog output will be automatically fixed at 3.6 mA.

**Power failure**

An EEPROM retains data record of totalized flow volume when pulse output is used.

**Power supply**

24V DC ± 10% or 100V AC ± 10%

**Power consumption**

2.4W max.

**Ambient temperature limits**

0 to 50°C

**Ambient humidity limits**

5 to 85% RH (no condensation)

**Optional specifications****Traceability certificate**

The following three documents are included.

- Traceability system chart
- Traceability certificate
- Test report

**PHYSICAL SPECIFICATIONS****Case material**

Polycarbonate

**Case cover material**

Polycarbonate

**INSTALLATION****Cable gland**

Plastic gland (3 pieces)

**Cable**

Applicable cable outer diameter: φ6 to φ12 mm

Applicable cable conductor

Power supply: AWG14 to 22 (0.32 to 2.03 mm<sup>2</sup>)Outputs: AWG16 to 26 (0.13 to 1.31 mm<sup>2</sup>)**Mounting**

Integral type

**Grounding**

Grounding resistance should be less than 100 Ω

**Piping vibration**4.9 m/s<sup>2</sup> max. (0.5 G max.)

**For detector****FUNCTIONAL SPECIFICATIONS****Type of protection**

IEC IP65 (for indoor use only)

**Temperature range of process fluid**

-20 to 90°C (no freezing)

**Pressure range of process fluid**2.0 MPa max. (20 kgf/cm<sup>2</sup> max.)**Measurable process fluid**Water, hot water  
(no corrosive fluid, no abrasive fluid)**Measurable electrical conductivity**

50 to 50,000 μS/cm

**Measurement flow range**

Size (mm)	Minimum range (m <sup>3</sup> /h)	Maximum range (m <sup>3</sup> /h)
15	0 to 0.637	0 to 3.18
25	0 to 1.768	0 to 8.835
40	0 to 4.524	0 to 22.619
50	0 to 7.069	0 to 35.342
65	0 to 11.946	0 to 59.729
80	0 to 18.096	0 to 90.477
100	0 to 28.275	0 to 141.371

**Size**

15, 25, 40, 50, 65, 80, 100 mm

**Flange rating**R1/2 internal thread, R1/2 external thread (15 mm)  
Wafer style (15 to 100 mm)  
JIS10K, JIS20K, ANSI150,  
JIS G3451 F12 (for size 80 mm or larger)**Ambient temperature limits**

0 to 50°C

**Ambient humidity limits**

5 to 85%RH (no condensation)

**PERFORMANCE SPECIFICATIONS****Accuracy**± 1% of rate (flow velocity: 0.5 to 5 m/s)  
± 0.05 m/s (flow velocity: 0.1 to 0.5 m/s)**Magnetic field effect**

± 0.2% F.S. (400A/m)

**PHYSICAL SPECIFICATIONS****Main body materials****Case material**

SUS304 stainless steel

**Measuring pipe material**

SUS304 stainless steel

**Process wetted materials****Lining**PFA (for size 15 mm)  
Polypropylene (for size 25 to 100 mm)**Electrode**

SUS316L stainless steel

**Grounding ring**

SUS304 stainless steel

**INSTALLATION****Pipe connection**

Wafer style

**Grounding**

Grounding resistance should be less than 100 Ω

**Length of straight pipe****Upstream side**A minimum of five straight pipe diameters  
A minimum of 10 straight pipe diameters is required if  
diffuser/valve/pump installed on the upstream side.**Downstream side**

Two straight pipe diameters are recommended.

**Mounting**

Integral style (installed on the piping)

**Optional specifications****Bolts and nuts**

Carbon steel

Carbon steel bolts and nuts for installing the detector  
on the piping are provided.

SUS304 stainless steel

SUS304 stainless steel bolts and nuts for installing the  
detector on the piping are provided.

**MODEL SELECTION**

**WaterMAG Electromagnetic flowmeter**

Basic model no.

**MCB10A**

Selection

Option

Size	15 mm	015					
	25 mm	025					
	40 mm	040					
	50 mm	050					
	65 mm	065					
	80 mm	080					
	100 mm	100					
Style code	Global model		GLB				
Power supply	100V AC		A				
	24V DC		G				
Centering jig (customer's piping)	Wafer JIS10K						11
	Wafer JIS20K						12
	Wafer ANSI150						21
	Wafer JIS G3451 F12 (for 80 mm or larger size)						31
	Union R1/2 external thread						U1
	Union R1/2 internal thread						U2
Bolts and nuts	None						X
	Carbon steel bolts and nuts						1
	SUS304 stainless steel bolts and nuts						2
Options	None						X
	Setting customer's required range						K
	Traceability certificate						B

**DIMENSIONS**

Union style: 15 mm

Weight: 2.3 kg

[Unit: mm]

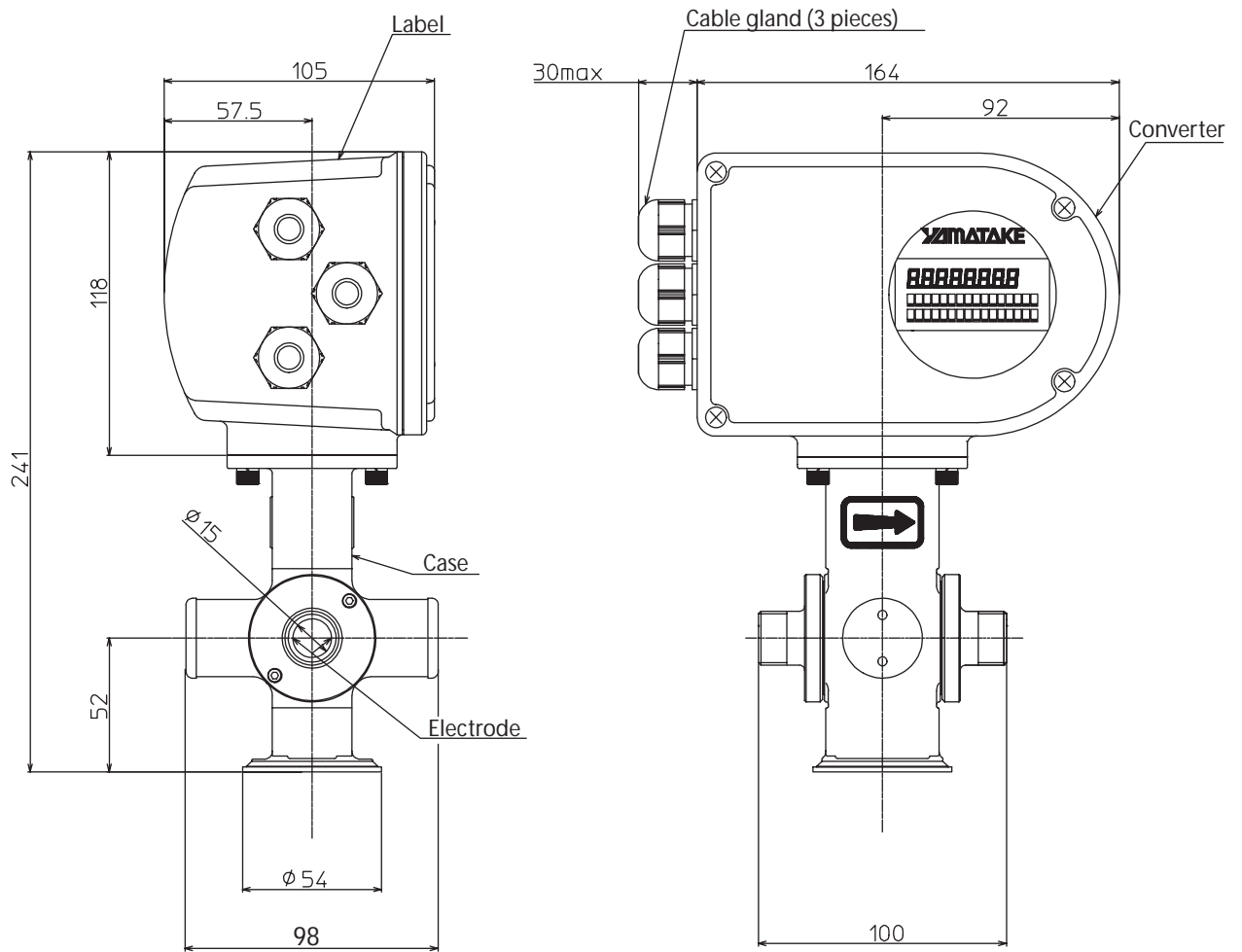

Wafer style: 15 mm

Weight: 2.1 kg

[Unit: mm]

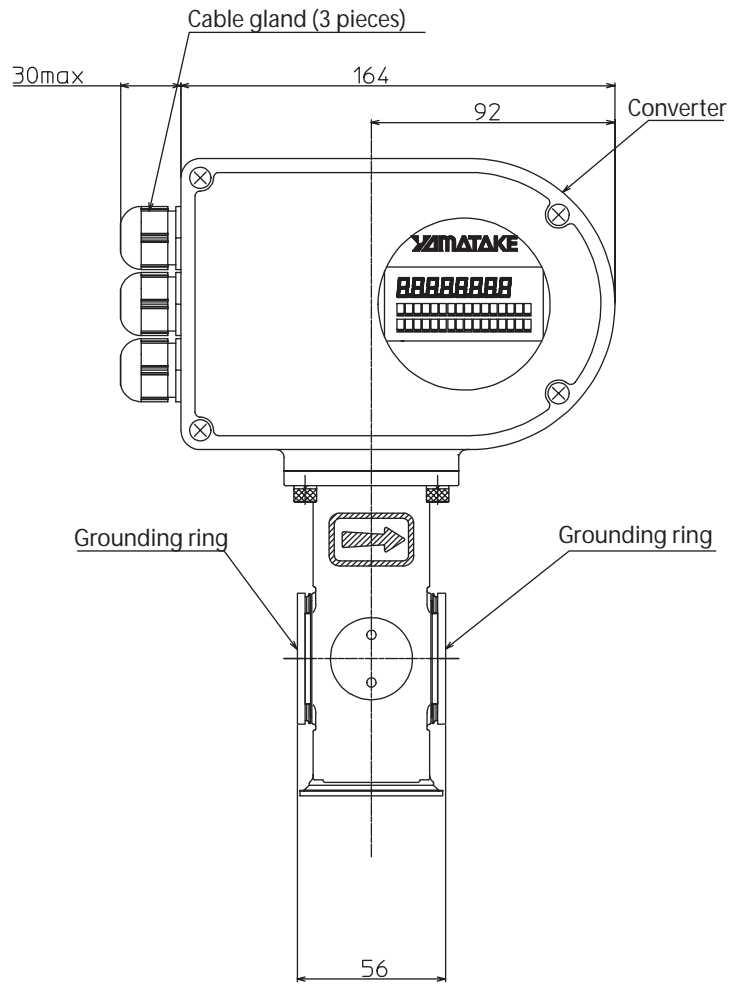
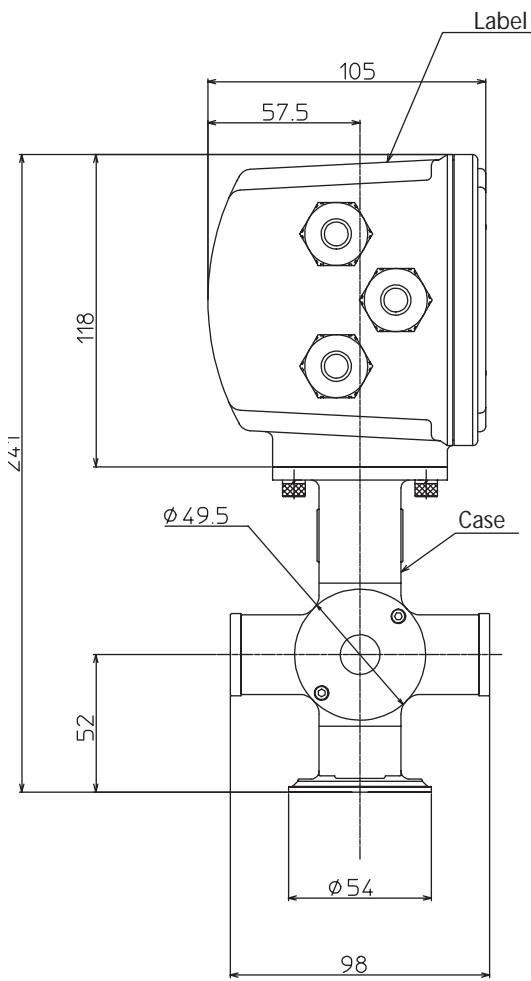

Wafer style: 25 to 100 mm

Nominal size (mm)		25	40	50	65	80	100
Face to face dimension (mm)	L	56	77	83	93	103	117
Height (mm)	H	229	245	263	280	293	318
	H1	34	43.5	52	62	67	79.5
Case outer diameter (mm)	D	68	87	104	124	134	159
Weight (kg)		1.9	2.3	2.9	3.3	4.2	5.3

[Unit: mm]

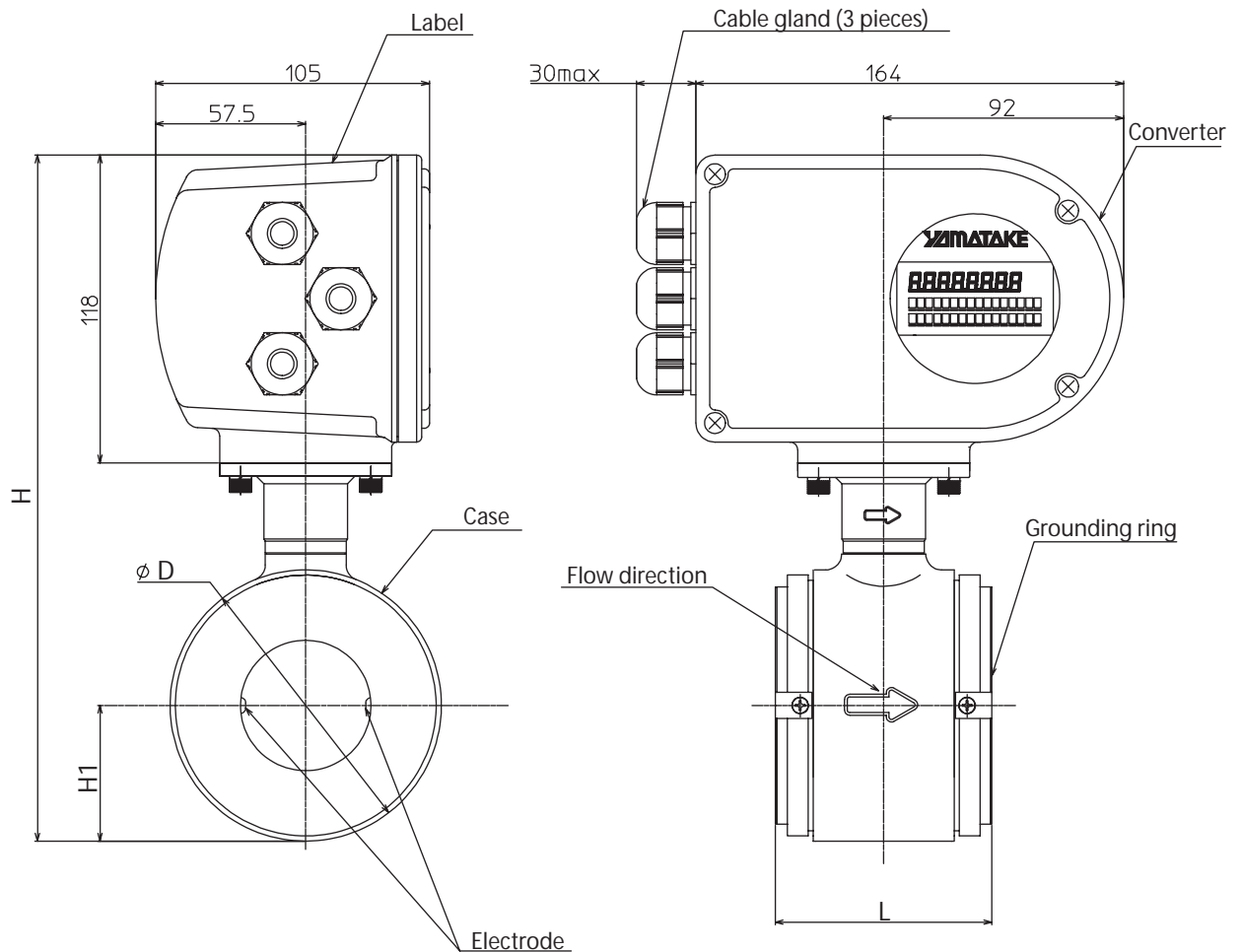

**azbil**

---

**Yamatake Corporation**  
**Advanced Automation Company**

1-12-2 Kawana, Fujisawa  
Kanagawa 251-8522 Japan

**URL:**<http://www.azbil.com>