

**Integral style electromagnetic flowmeter  
for filling machines  
Model: MGR11A**

**User's Manual**

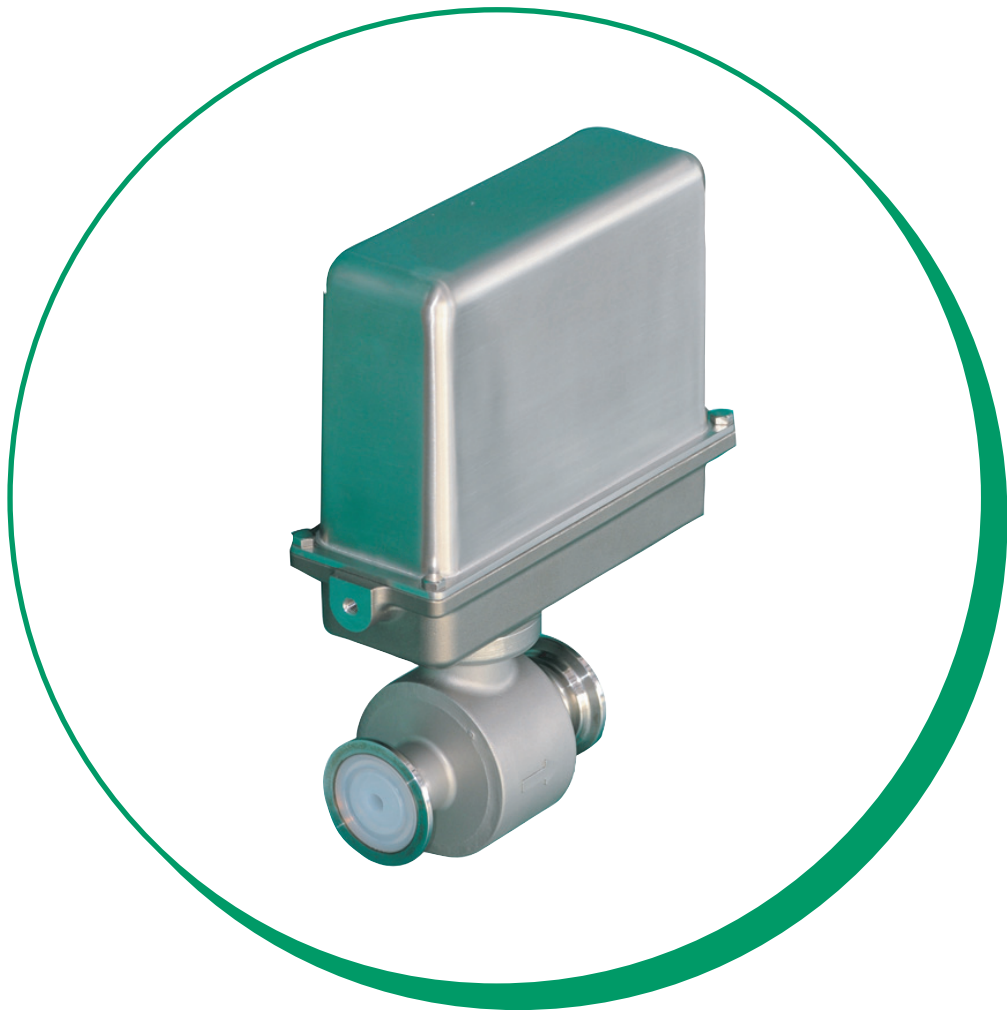

Yamatake Corporation

# NOTICE

---

While the information in this manual is presented in good faith and believed to be accurate, Yamatake Corporation disclaims any implied warranty of merchantability or fitness for a particular purpose and makes no express warranty except as may be stated in its written agreement with and for its customer.

In no event shall Yamatake Corporation be liable to anyone for any indirect, special or consequential damages. This information and specifications in this document are subject to change without notice.

# Table of Contents

---

---

## **Chapter 1 :Introduction**

1.1 :Packing and, confirmation and storage of the product .....	1-1
1.2 :Safety precautions.....	1-2
1.3 :CE mark .....	1-2

## **Chapter 2 :Flowmeter installation**

2.1 :Ambient environment .....	2-1
2.2 :Pipe connection.....	2-1
2.3 :Gasket .....	2-2
2.3.1:Tightening the clamp .....	2-2
2.3.2:Replacing the gasket.....	2-2
2.3.3:Selecting the gasket .....	2-3
2.4 :Support mounting.....	2-3
2.5 :Converter cover.....	2-4
2.6 :Conduit.....	2-4
2.7 :Air purge.....	2-5
2.8 :Cleaning and sterilization temperature.....	2-5
2.9 :Converter wiring .....	2-6
2.9.1:Wiring connection table .....	2-6
2.9.2:Open collector pulse output wiring .....	2-7
2.9.3:Master/slave function.....	2-8
2.9.4:Synchronizing signal output/input wiring .....	2-9

## **Chapter 3 :Electric wiring**

3.1 :End terminal processing.....	3-1
3.2 :Pressure terminal crimping.....	3-1
3.3 :Connection to the customer terminal.....	3-2
3.4 :Fixing by wire clamps .....	3-2

## **Chapter 4 :Converter settings**

4.1 :Range.....	4-1
4.2 :Pulse weight.....	4-1
4.3 :Pulse width .....	4-1
4.4 :Dropout.....	4-1
4.5 :DF value .....	4-1
4.6 :Burnout setting .....	4-2

## *Table of Contents*

---

---

4.7 : Burnout setting (master/slave failure)..... 4-2

### ***Chapter 5 :Preliminary preparation for flow rate measurement***

5.1 :Warm-up operation..... 5-1

5.2 :Zero adjustment ..... 5-1

### ***Chapter 6 :Recommended replacement period***

### ***Chapter 7 :Troubleshooting***

7.1 :Master/slave converter failure ..... 7-1

## List of Figure

---

---

Figure 2-1	Detector placementFerrule dimensions (unit: mm) .....	2-2
Figure 2-2	Installation drawing of support mounting.....	2-3
Figure 2-3	Conduit structure.....	2-4
Figure 2-4	Mounting diagram for air purge .....	2-5
Figure 2-5	Wiring connection table .....	2-6
Figure 2-6	Wiring diagram for pulse output .....	2-7
Figure 2-7	Wiring diagram for synchronizing signal output/input.....	2-9
Figure 3-1	Power/bus cables.....	3-1
Figure 3-2	Synchronizing signal cable.....	3-1
Figure 3-3	Wiring diagram to the customer terminal .....	3-2
Figure 3-4	Cable fixing position .....	3-2
Figure 5-1	LED indication when the adjustment is completed successfully.....	5-1
Figure 5-2	LED indication when the adjustment has failed.....	5-2

*List of Table*

---

---

Table 1 ..... 1-2

---

---

# Chapter 1 : Introduction

## Overview

This electromagnetic flowmeter for integrated filling machines is a flowmeter for applications incorporated in a filling machine. It has a fast response and is applicable to applications with complicated piping.

## 1.1 : Packing and, confirmation and storage of the product

### Unpacking

This product is a precision machine. Handle the flowmeter with care when unpacking to prevent an accident and damage. Confirm that the following items are included in the package.

- Flowmeter body
- Gasket and, when selected, ferrule

### Confirming the specification

The specification is described on the Name plate of the flowmeter. Refer to Appendix A "Standard Specification, Model Number and Appearance of this Product" to check that the specification is correct.

- Basic model No.
- Diameter
- Gasket type
- Presence or absence of gasket and ferrule

### Inquiry

If you have any questions about the specification, contact your local office of Yamatake. When you contact us, please have your MODEL NO. and PRODUCT NO. ready.

### Precautions for storage

When you store the product in an unused state, observe the following points.

- Keep the product in a vibration- and shock-free indoor place at room temperature and normal humidity.
- Store the product without unpacking.

When you store the product after use, follow the steps below.

- (1) Tighten the cover of the flowmeter body to keep out humidity.

- (2) Pack the product as before it was unpacked.
- (3) Keep the product in a vibration- and shock-free indoor place at room temperature and normal humidity.

## 1.2 : Safety precautions

### Overview

For safe use of this product, be sure to install and operate the flowmeter properly and perform maintenance adequately. Read the safety precautions in this manual carefully before installing and operating the flowmeter, and performing maintenance.

### Precautions

The following symbols are used in this manual to ensure user safety.

#### **WARNING**

---

This symbol is used to warn of hazards where failure to observe a safety instruction may result in death or serious injury.

---

#### **CAUTION**

---

This symbol is used to warn of hazards where failure to observe a safety instruction may result in injury or physical damage.

---

## 1.3 : CE mark

### Overview

This product conforms to CE mark standard. The declaration of conformity is shown below.

### Declaration of conformity

The declaration of conformity consists of two documents.

**Table 1**

Name	Description
CE Conformity Supplement	Describes compliant items regarding EMC Directive/ Standard and LV Directive that this product meets.

## Yamatake Corporation

MagneW3000 Hyper Electromagnetic Flowmeter  
CE Conformity Supplement

**CE CONFORMITY:** This product is in conformity with the protection requirements of the following European Council Directive: **2004/108/EC**, the EMC Directive. Conformity of this product with any other iCE Marki Directive(s) shall not be assumed.

EMC Directive/Standard	PC	Conformity	Notes
<b>ELECTROMAGNETIC COMPATIBILITY:2004/108/EC</b> , EMC Directive			
<b>EMISSIONS:EN61326-1:2006, Gr.1 Class A</b> , Electrical equipment for measurement, control and laboratory use			
<b>EN 55011:2007 /A2:2007, Gr.1, Class A</b> , Industrial Control Equipment, Radiated electromagnetic disturbances 30MHz -1000MHz,		30MHz-230MHz quasi-peak limit 40dB(uV/m) at 10m 230MHz-1000MHz quasi-peak limit 47dB(uV/m) at 10m	
<b>IMMUNITY: EN61326-1:2006</b> , Electrical equipment for measurement, control and laboratory use, <b>EN 61326-2-3 :2006</b> , Particular requirements		<b>PERFORMANCE:</b> Unless otherwise noted, the performance of this product, at the specified levels of electromagnetic interference, is within the specifications for performance Under Rated Conditions.†	
<b>IEC 61000-4-2:1995+A1:1998+A2:2001</b> , ESD, Electrostatic Discharge	B B	4 kV Contact 8kV Air	
<b>IEC 61000-4-3:2006</b> , Radio-frequency electromagnetic field, amplitude modulated 80 ñ2700 MHz	A	1kHz, AM80% 10 V/m (80 ñ1000 MHz) 3V/m (1.0 ñ2.0 GHz) 1V/m (2.0 ñ2.7 GHz)	
<b>IEC 61000-4-4:2004</b> , Electrical Fast Transients/Burst	B	½2 kV DC Power ½1 kV I/O signal/control	
<b>IEC 61000-4-5:2006</b> , Surge	B	½1kV Line to line :Power Lines ½2kV Line to ground :Power Lines ½1kV Line to ground: I/O signal/control Lines	1
<b>IEC 61000-4-6:2007</b> , Conducted Radio-frequency, 150 KHz - 80 MHz	A	3V	
<b>IEC 61000-4-8:1993+A1:2001</b> , Power frequency magnetic field	A	30 A/m 50Hz	

## NOTES:

PC = Performance Criteria

1. I/O signal/control Lines was not tested in accordance with EN61326-1 Table 2 NOTE (c). The equipment has signal lines less than 30 m.

**Performance Criteria:** Immunity includes the tests and severity levels specified in EN 61326-1-2006 and EN 61326-2-3-2006.

Yamatake Proprietary

# MEMO

---

---

# Chapter 2 : Flowmeter installation

## 2.1 : Ambient environment

Install the flowmeter in a place where the ambient temperature is between -5 and 50°C.

### CAUTION

Do not use the flowmeter in a constantly high temperature state. Doing so may affect the flowmeter life. It is recommended to use this product between 20 and 25°C. Install the flowmeter to a low-vibration place (less than 500 Hz 4.9 m/s<sup>2</sup>). Failure to do so may cause damage to the detector or instrument.

## 2.2 : Pipe connection

- (1) Use ISO clamps for the connection. Use clamps for 1S clamp.
- (2) The flow direction mark arrow that is set on the case of the detector section indicates the direction in which the fluid flows. Match the direction of the fluid flow and the direction of the arrow. Do not weld pipes after installing the flowmeter.
- (3) Install the flowmeter so that the flow channel of the detector section is set at a position where it is filled with fluid.
- (4) Ensure straight pipe sections for the upstream side and downstream side in the installation site.

For detector with 8 mm diameter	
Upstream side	Ensure 15D or greater (Ensure a straight pipe section of 120 mm or more from the edge of the detector section upstream side, and inside diameter 8 mm ± 0.2 mm.). Use a straight pipe whose diameter is greater than 8 mm for upstream side of 15D.
Downstream side	Ensure 2D or greater (Ensure a straight pipe section of 16 mm or more from the edge of the detector section upstream side, and inside diameter 8 mm ± 0.2 mm.).

For detector with 15 mm diameter	
Upstream side	Ensure 15D or greater (Ensure a straight pipe section of 180 mm or more from the edge of the detector section upstream side, and inside diameter 15 mm ± 0.2 mm.). Use a straight pipe whose diameter is greater than 15 mm for upstream side of 15D.
Downstream side	Ensure 2D or greater (Ensure a straight pipe section of 16 mm or more from the edge of the detector section upstream side, and inside diameter 8 mm ± 0.2 mm.). Be sure to ensure the required straight pipe length for the upstream side. Failure to do so may affect the repeatability. If an plastic pipe such as a Teflon tube is used for piping of the upstream side, ensure the straight pipe length of 20D or greater between the plastic pipe and the flowmeter.

- (5) As a pipe connected to the detector, use a pipe of 8 mm ± 0.2 mm for models with 8 mm diameter and a pipe of 15 mm ± 0.2 mm for models with 15 mm diameter.

**~Note** *Note that if the piping of the upstream side length is less than 15D, the repeatability of filling amount will be affected.*

## 2.3 : Gasket

**⚠ CAUTION**

Be careful not to allow the gaskets to protrude into the flow channel. Failure to do so may affect the repeatability of the filling amount. Do not tighten the clamps too much. Doing so may shorten the service life of and damage the gasket.

### 2.3.1: Tightening the clamp

Adjust the tightening force of the clamp while checking that the gasket is not protruding into the inside diameter.

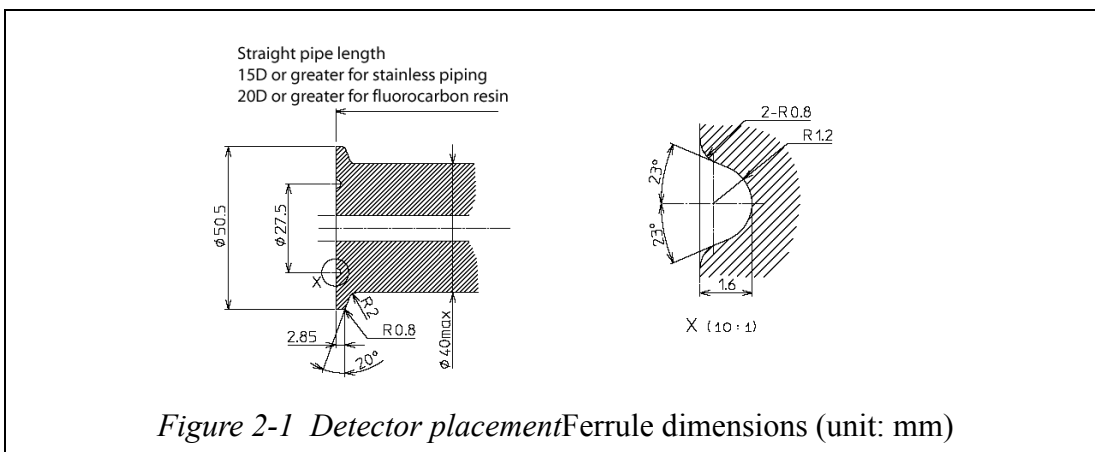

### 2.3.2: Replacing the gasket

Gaskets may be deformed and tarnished by the effect of CIP (cleaning in place) and SIP (sterilizing in place) with some differences depending on the material (EPDM and Kalrez (perfluoroelastomer)). It is recommended to check and change the gasket periodically.

### 2.3.3: Selecting the gasket

EPDM and Kalrez (perfluoroelastomer) are available as optional materials for the gasket. Select one of them in accordance with the following conditions.

#### EPDM gasket:

Used for cleaning at a temperature under 120°C. EPDM tends to be less resistant than Kalrez to SIP. EPDM gaskets generally have better anti-corrosion characteristics than silicon gaskets for CIP. However, they may need to be changed periodically depending on the chemical agent for cleaning.

#### Kalrez gasket:

Used for SIP at a temperature under 150°C or for frequently-performed CIP. Kalrez gaskets are less swelling and have better anti-corrosion characteristics than silicon and EPDM gaskets and thus can be used for longer periods.

## 2.4 : Support mounting

A 10 mm-deep screw hole to mount the support is provided on the case for an M6 screw. Mount the support using the support mounting screw.

### ⚠ CAUTION

The support serves the function of bearing the weight of the flowmeter so that the pipes are not damaged by the full weight of the flowmeter after the flowmeter is mounted with clamps. Be sure to mount the support. Use of the flowmeter without the support may cause the flowmeter to fall.

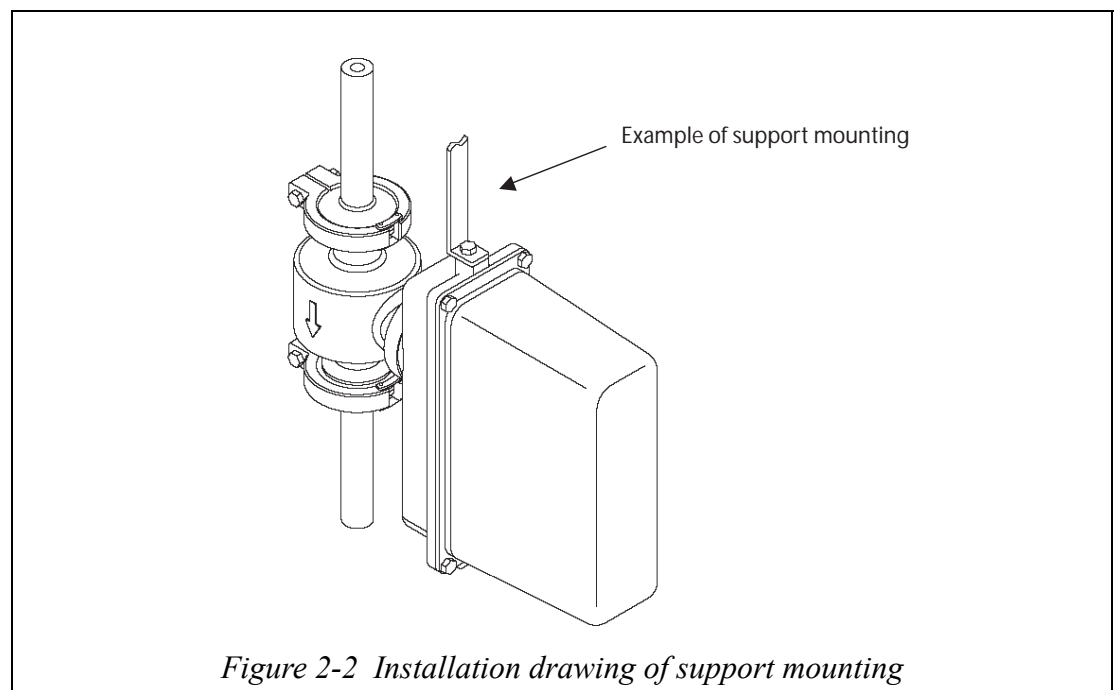

## 2.5 : Converter cover

The converter cover is fixed with four M5 hexagonal bolts.

### ⚠ CAUTION

- When removing the cover for wiring or other purposes, loosen the bolts while holding the cover. Failure to do so may cause the cover to fall, thereby resulting in injury.
- When removing the cover, be careful not to let moisture or water enter the converter. Failure to do so may cause an instrument failure. When reattaching the cover, make sure that the gasket is not protruding or misaligned.

## 2.6 : Conduit

The conduit for electric wiring and an air purging tube has an R3/4 tapered-thread structure.

### ⚠ CAUTION

- Securely seal the conduit to prevent water from entering. Failure to do so may cause an instrument failure.
- Set the conduit downward so that water does not enter, and securely seal the conduit using a watertight gland. Failure to do so may affect the product life.

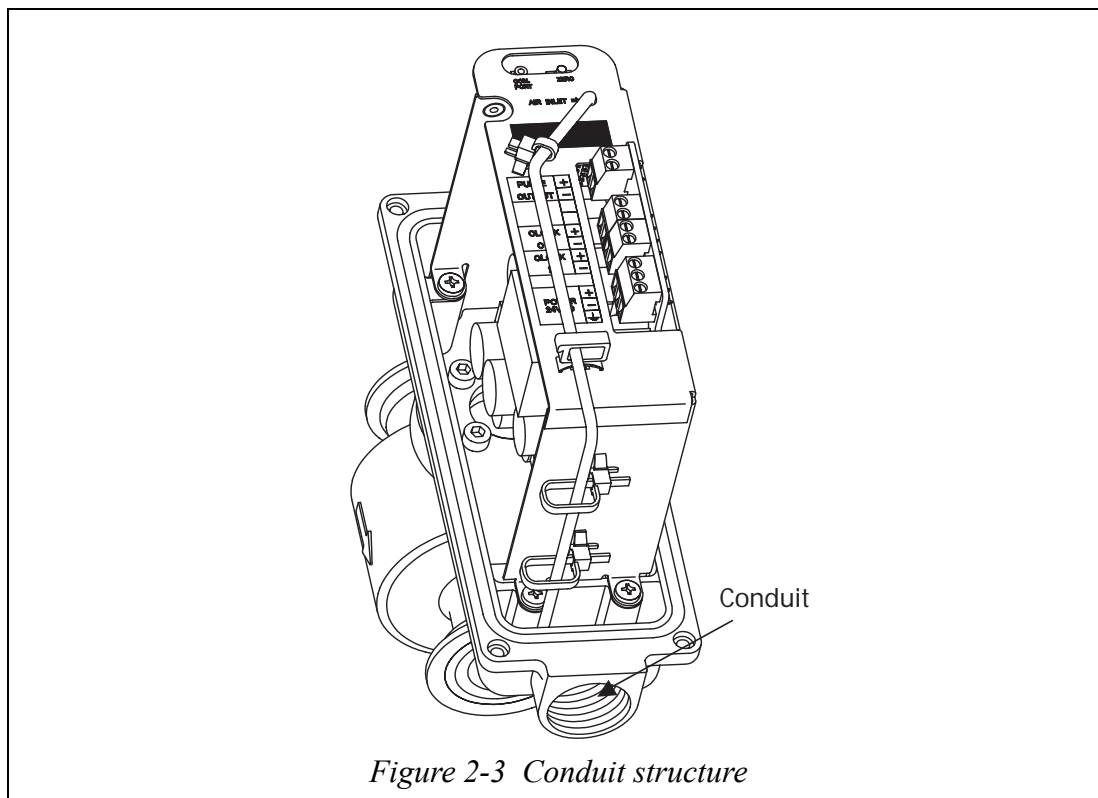

## 2.7 : Air purge

Perform air purge so that the pressure inside the converter becomes higher than that of the ambient environment.

Supply air continuously as specified below.

Airflow: 400 L/h [N] or higher

Air temperature: 25°C

Recommended air purge

Flow rate: 400 L/h [N] or higher

Temperature: 25°C or less

Installation: Insert the air purge tube into the hole of the bracket inside the flowmeter and fix it before use.

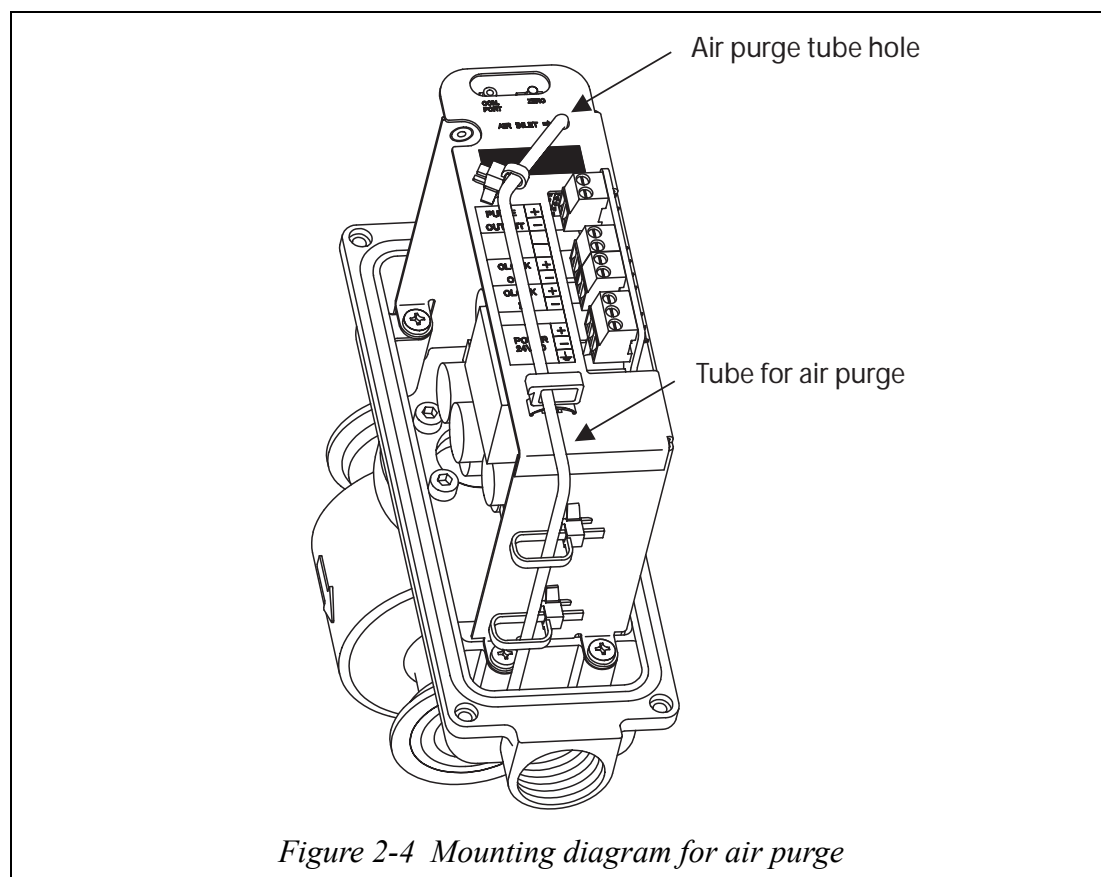

## 2.8 : Cleaning and sterilization temperature

SIP and CIP can be used under the following conditions. However, the flowmeter life may be shortened if cleaning is performed longer or more frequently than the time or frequency described below.

SIP (Sterilizing In Place): 140°C or lower for an hour (once a day)

CIP (Cleaning In Place): 90°C or lower for an hour (once a day)

## 2.9 : Converter wiring

### 2.9.1: Wiring connection table

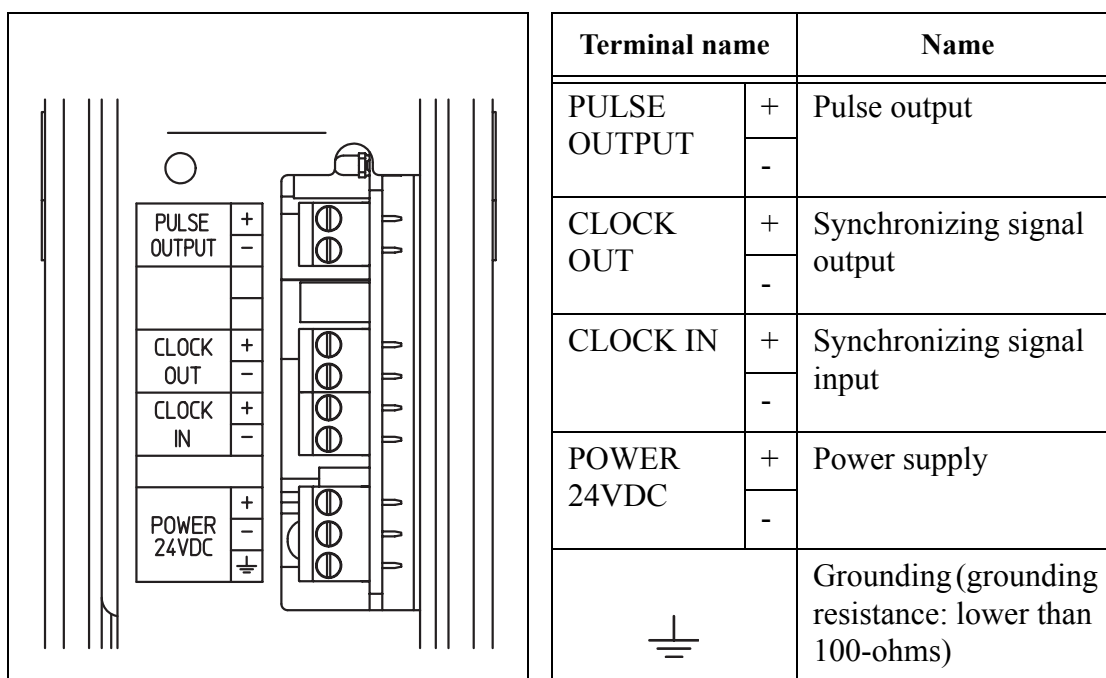

Figure 2-5 Wiring connection table

### CAUTION

The specification of the power supply is 24 V DC ± 10%. Connecting to AC power supply may cause an instrument failure. Be sure to connect properly.

## 2.9.2: Open collector pulse output wiring

Open collector output: (NPN type)

External power supply voltage: 24 V DC/12 V DC

Output current: 50 mA max

Rising and falling: 5 μs TYP. (DC24 V)

Be sure to ground the power supply for safety.

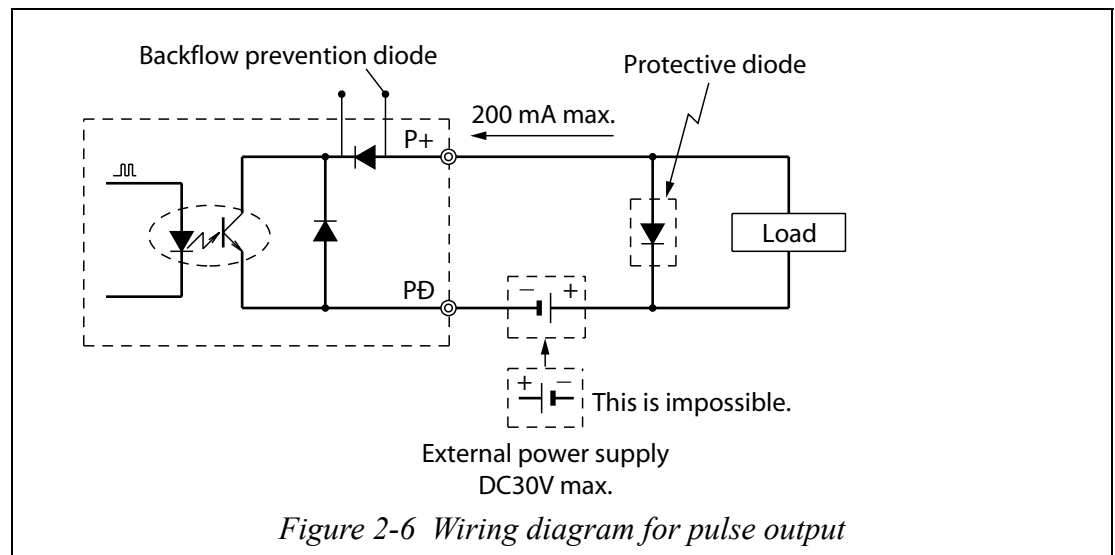

Voltage	Voltage drop (closed circuit) (HIGH voltage)	Voltage drop (open circuit) (LOW voltage)
DC 24V	19V min	2.5V max
DC 12V	7V min	2.5V max

## 2.9.3: Master/slave function

When more than one electromagnetic flowmeter for integrated filling machines is used simultaneously, the configuration should have a master flowmeter and multiple slave flowmeters.

The number of flowmeters (The number of valves)	Master flowmeter	Slave flowmeter
1	1	0
2 or more	1	1 to 168

### (1) Description of the function

The master flowmeter transmits a synchronizing signal that determines the frequency of the excitation current to the first slave flowmeter. The first slave flowmeter transmits the synchronizing signal to the second slave flowmeter. This function is used to prevent mutual interference of the magnetic field when the instrumentation for the detector section of the electromagnetic flowmeter for integrated filling machines is complicated.

### (2) Function setting

Setting of master/slave function is made based on the model number at the time of delivery.

Master function: MGR11A~~ -M-~. .

Slave function: MGR11A~~ -S~

### CAUTION

Do not connect the Yamatake flowmeter to a single filling machine together with any flowmeter made by another company. Doing so may cause interference of the magnetic field, thereby affecting the repeatability of filling amount. When using more than one flowmeter, be sure to set them in the correct master/slave configuration.

## 2.9.4: Synchronizing signal output/input wiring

Get synchronizing signal cables ready. Connect CLOCKOUT± of the master flowmeter and CLOCKIN± of the slave flowmeter with the synchronizing signal cables.

When connecting multiple flowmeters, connect CLOCKOUT± of the higher-level slave flowmeter and CLOCKIN± of the lower-level slave flowmeter. Unless all of the flowmeters are connected properly, accurate measurements of the flow rate cannot be provided.

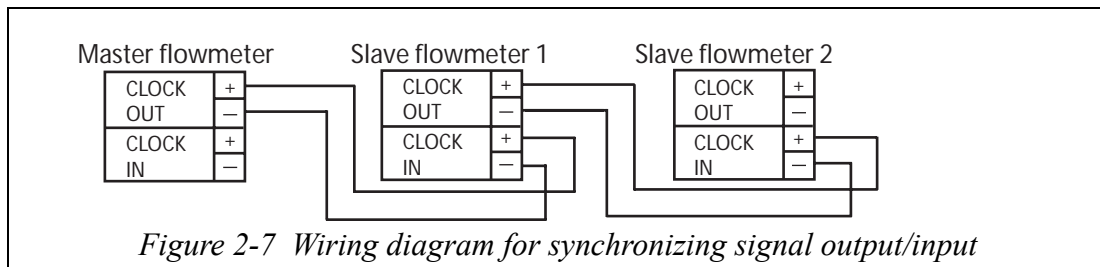

# MEMO

---

---

# Chapter 3 : Electric wiring

## 3.1 : End terminal processing

Process the end terminals in accordance with Figure 3-1 and Figure 3-2 .

Recommended cables: Power/bus cable: MVVS 0.5sq 4-cores

Synchronizing signal cable: OTSC[U]-VB 0.5sq 1-pair

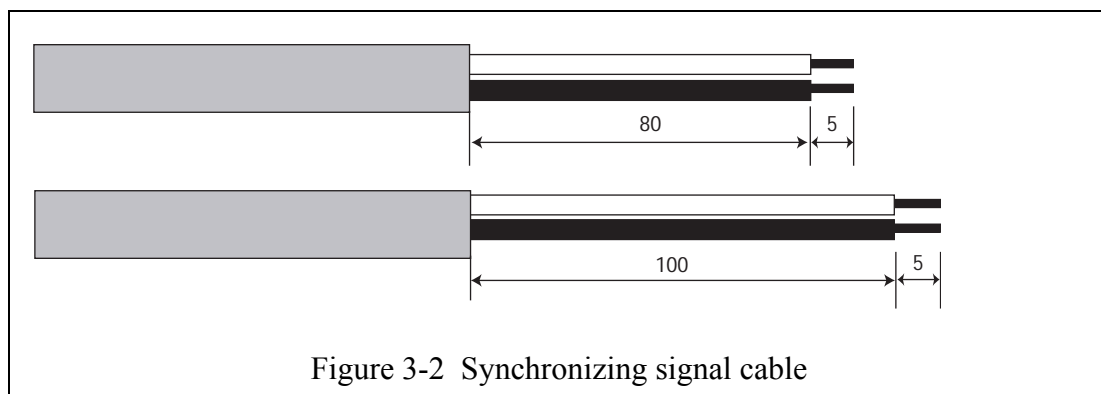
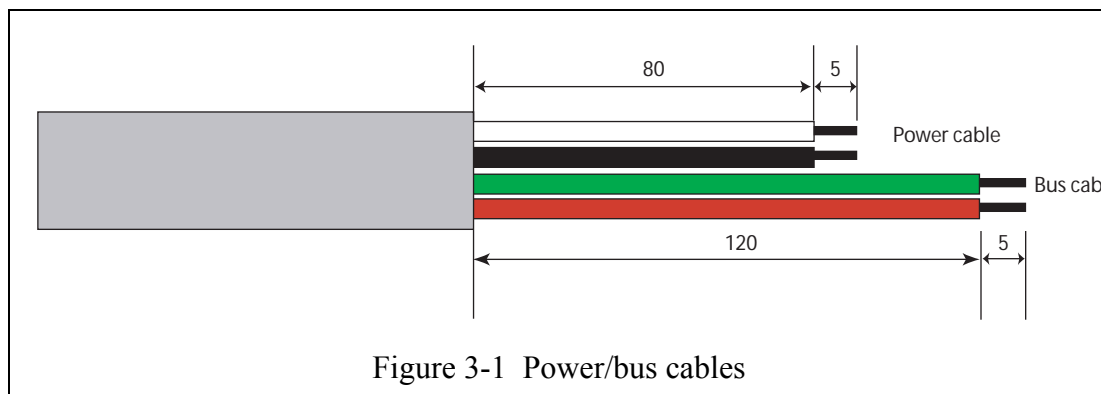

## 3.2 : Pressure terminal crimping

Crimp a pressure terminal to the core of each cable using a specialized tool. Use pressure terminals (AIO, 5-6WH) made by PHOENIX CONTACT.

### 3.3 : Connection to the customer terminal

Wire each cable in accordance with the following wiring diagram.

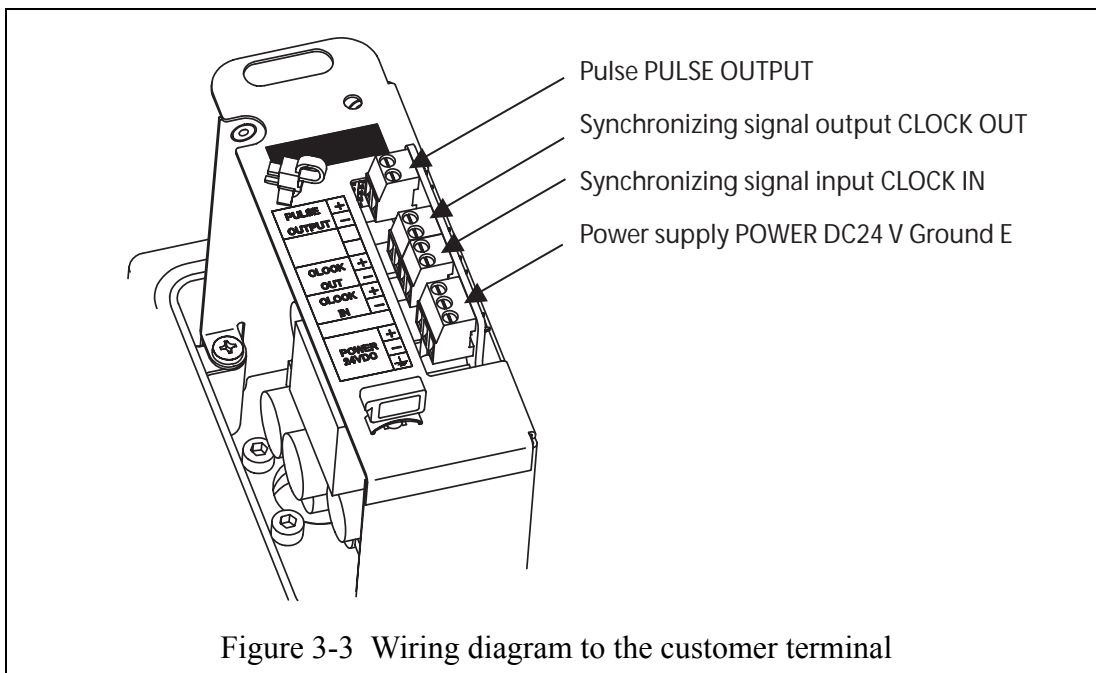

### 3.4 : Fixing by wire clamps

Fix each cable using wire clamps.

- (1) After bundling the cables together with binding bands, cut the surplus part of the band.
- (2) Bundle together cables that were separated into parts after processing the end terminal and fix them using a wire clamp.

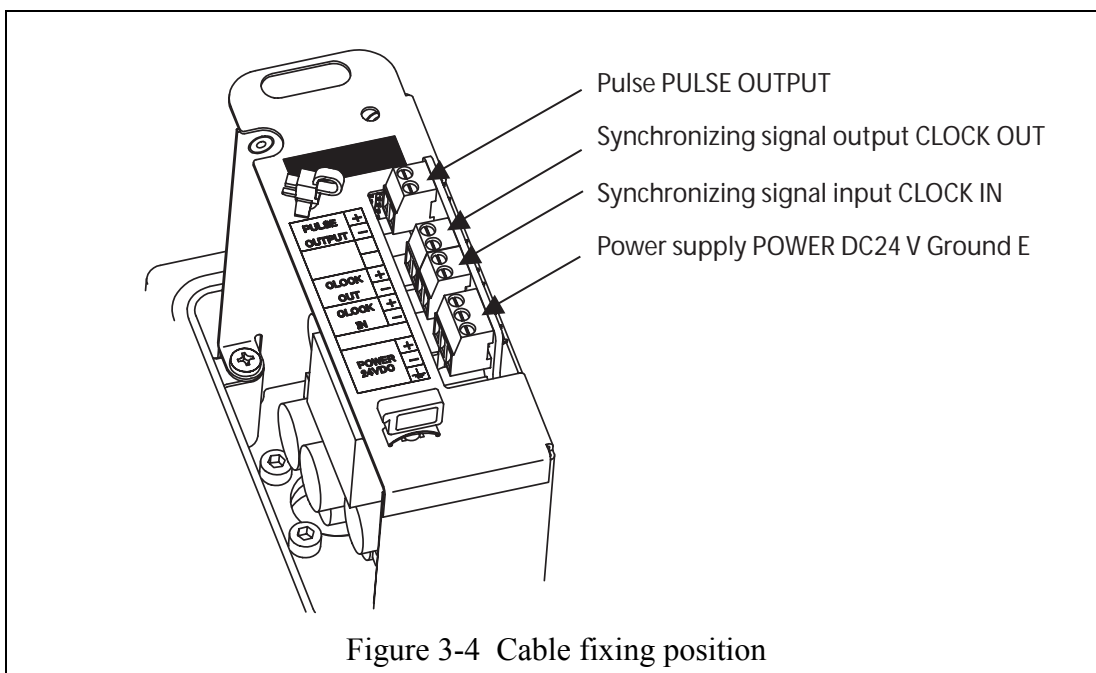

---

---

# Chapter 4 : Converter settings

The factory default of the converter is set as instructed by the customer. If you use it in its initial settings or need to change the settings in your location, contact Yamatake affiliates. It is possible to perform zero adjustment for the flowmeter alone.

## 4.1 : Range

The flow range of this flowmeter is fixed to 300 mL/s. It is possible to output 150% of the range correctly.

## 4.2 : Pulse weight

The pulse weight is fixed to 0.05 mL/P. As the range is 300 mL/s, the span frequency of 6000 Hz is output at 100% of the range.

For flow rate over the range, it is possible to output up to about 150% correctly.

## 4.3 : Pulse width

The pulse width is fixed to 30  $\mu$ s.

Pulse width setting	Tolerance
30 $\mu$ s	30 $\pm$ 5 $\mu$ s

Pulse rise time and fall time 5  $\mu$ s TYP. (with 24 V DC power)

## 4.4 : Dropout

The default setting is 3%.

Dropout is a function to stop the pulse output that is unrelated to the flow rate (pulse output generated by the fluctuation of flow rate near the zero point).

If a certain amount of fluid flows at a percentage of around the dropout value, the pulse output may be output and stopped repeatedly due to change in flow rate.

## 4.5 : DF value

The DF value is a characteristic number determined by the calibration at the factory before shipment.

## 4.6 : Burnout setting

The state of pulse output, in case a failure occurs in the self-diagnostics at power-on and thus the flow rate cannot be measured, can be determined.

LOW (default): No pulse is output.

## 4.7 : Burnout setting (master/slave failure)

The state of pulse output in case a master/slave failure occurs can be determined.

Don't care (default): The regular flow rate measurement is continued.

---

---

# Chapter 5 : Preliminary preparation for flow rate measurement

When the installation, electric wiring and settings of the flowmeter are completed, perform the preliminary preparation for flow rate measurement.

## 5.1 : Warm-up operation

Operate the equipment for at least 30 minutes after turning ON the power to warm it up. If power is turned OFF once and ON again, wait for at least 10 minutes for equipment warm-up.

### ⚠ CAUTION

PFA lining is used for this electromagnetic flowmeter. If the high-temperature fluid and the low-temperature fluid are switched frequently, the constant temperature inside the lining cannot be maintained. When they need to be switched frequently, ensure a 30-minute or longer warm-up time to stabilize the lining.

## 5.2 : Zero adjustment

- (1) Fill the fluid inside of the detector and confirm that the fluid is in a resting condition.
- (2) Zeroing the flowmeter. Zero adjustment is automatically performed by operating holding down the switch for over a second. Confirm that the green LED on the main board goes out for five seconds then lights up. If the adjustment fails, the LED blinks for 20 seconds. Check the water-submersion and resting condition in the pipes and then perform zero adjustment again.

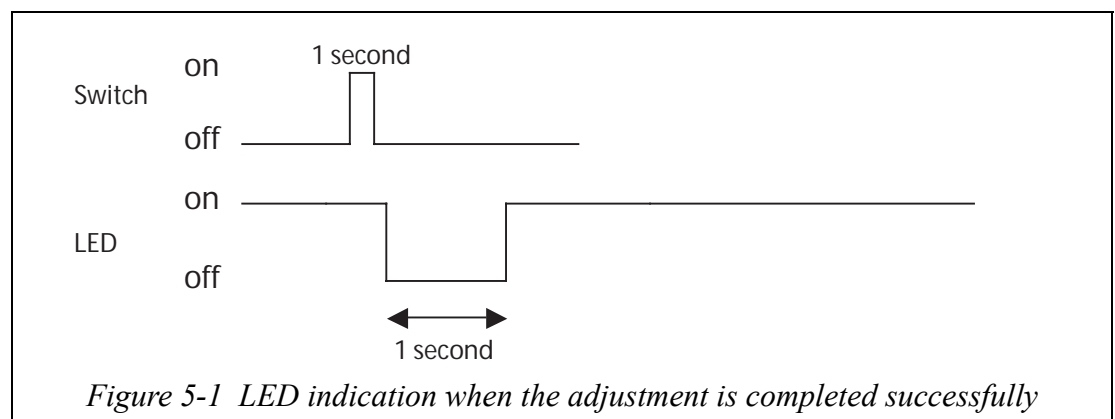
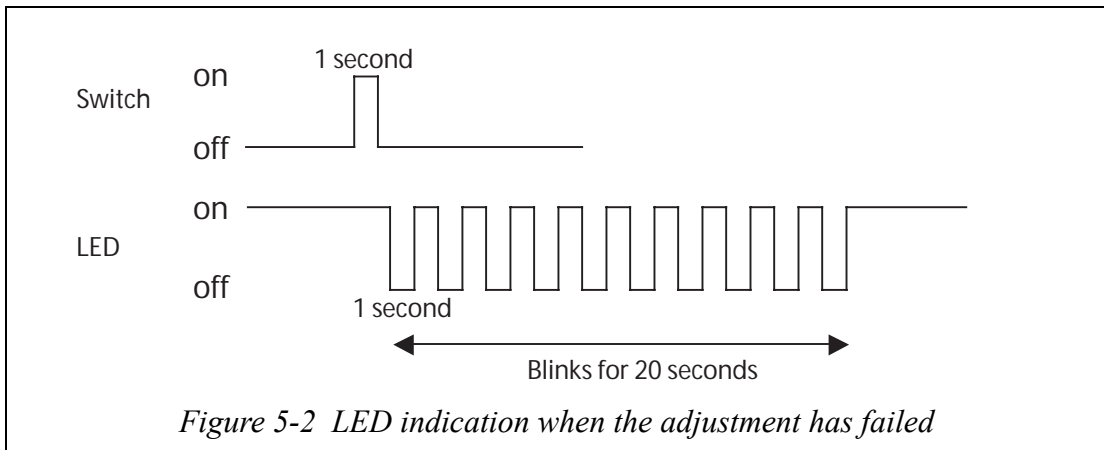

Figure 5-1 LED indication when the adjustment is completed successfully



Be sure to perform zero adjustment after the pipes are mounted. Failure to do so will cause a shift of the zero point as the reference value of the range, thereby shifting the dropout value and the pulse weight value, but does not affect the repeatability.

---

---

## Chapter 6 : Recommended replacement period

The entire flowmeter: 5 years

Since the electronic components will deteriorate rapidly after the recommended replacement period, have spare parts ready.

Gaskets are supposed to be consumables. Although the rate of deterioration of gaskets varies depending on the use environment, check the condition of the gaskets as needed and change them within a year.

Name	Material	Diameter 8 mm	Diameter 15 mm
Gasket (flow channel)	EPDM	80383436-002	80382478-002
	Kalrez	80383436-003	80382478-003
	Silicon	80383436-001	80382478-001
Gasket (flow case)	EPDM	80383407-001	80383407-001



# Chapter 7 : Troubleshooting

## 7.1 : Master/slave converter failure

The following table shows the types and phenomena of master/slave failure, assumed causes, and how to respond to the failures.

Master/slave failure	Phenomena	Action of the flowmeter	Assumed causes		Measures	
Master flowmeter	When a synchronizing signal is input to the CLOCKIN terminal of the master flowmeter	The red LED on the power supply board blinks at intervals of one second and the flowmeter enters the master/slave failure state. However, it continues to function normally. *2	1	Model No. mismatching	Check the power supply and wiring.	
					1	Check the model number and the setting of master/slave switch.
			2	Improper wiring	2	As the master flowmeter does not need any connection to CLOCKIN, disconnect it.
			3	Flowmeter abnormality	3	Change the flowmeter.
Master flowmeter	When a synchronizing signal is not input to the CLOCKIN terminal of the slave flowmeter	The red LED on the power supply board blinks at intervals of one second and the flowmeter enters the master/slave failure state. However, it automatically changes its function as a slave flowmeter. *1, 2	1	Model No. mismatching	Check the power supply and wiring.	
					1	Check the model number and the setting of master/slave switch.
			2	Unconnected wiring or cable disconnection for synchronizing signals	2	As a slave flowmeter needs a connection to CLOCKIN, connect it.
			3	Abnormality in the anterior master or slave flowmeter	3	Change the anterior flowmeter.
			4	Abnormality in this flowmeter	4	Change the flowmeter.

**~Note**      *\*1 Two master flowmeters exist and interference of the magnetic field occurs at anterior or posterior position of the flowmeter that has changed from slave to master, thereby affecting the repeatability of filling amount. Take the proper measure as soon as possible.*

*\*2 The condition of pulse output depends on the burnout setting (master/slave failure).*

# MEMO

---

<b>Document Number:</b>	CM2-MGR200-2001
<b>Document Name:</b>	Integral style electromagnetic flowmeter for filling machines Model: MGR11A User's Manual
<b>Date:</b>	May. 2009 (initial)
<b>Issued/Edited by:</b>	Yamatake Corporation

---

**Yamatake Corporation**