

DMC10

Distributed Multi-channel Controller and SLP-D10 Smart Loader Package User's Manual



Thank you for purchasing the DMC10 Distributed Multi-channel Controller. This manual describes the DMC10 and the SLP-D10 Smart Loader Package. This manual contains information for ensuring correct use of the DMC10. It also provides necessary information for installation, maintenance, and troubleshooting. This manual should be read by those who design and maintain devices that use the DMC10. Be sure to keep this manual nearby for handy reference.

RESTRICTIONS ON USE

This product has been designed, developed and manufactured for general-purpose application in machinery and equipment.

Accordingly, when used in applications outlined below, special care should be taken to implement a fail-safe and/or redundant design concept as well as a periodic maintenance program.

- Safety devices for plant worker protection
- Start/stop control devices for transportation and material handling machines
- Aeronautical/aerospace machines
- Control devices for nuclear reactors

Never use this product in applications where human safety may be put at risk.

NOTICE

Be sure that the user receives this manual before the product is used.

Copying or duplicating this user's manual in part or in whole is forbidden. The information and specifications in this manual are subject to change without notice.

Considerable effort has been made to ensure that this manual is free from inaccuracies and omissions. If you should find an error or omission, please contact Yamatake Corporation.

In no event is Yamatake Corporation liable to anyone for any indirect, special or consequential damages as a result of using this product.

©2000 Yamatake Corporation ALL RIGHTS RESERVED

The DMC™ is a trademark of Yamatake Corporation in Japan.

SAFETY PRECAUTIONS

■ About Icons

The safety precautions described in this manual are indicated by various icons. Please be sure you read and understand the icons and their meanings described below before reading the rest of the manual.

Safety precautions are intended to ensure the safe and correct use of this product, to prevent injury to the operator and others, and to prevent damage to property. Be sure to observe these safety precautions.



 **WARNING**

Warnings are indicated when mishandling this product might result in death or serious injury.

















 **CAUTION**

Cautions are indicated when mishandling this product might result in minor injury to the user, or only physical damage to the product.

■ Examples

	Use caution when handling the product.
	The indicated action is prohibited.
	Be sure to follow the indicated instructions.

CAUTION

	Before wiring or installing the DMC10, be sure to turn the power OFF. Failure to do so might cause faulty operation.
	Do not remove or attach the DMC10 from or to the base while its power is ON. Doing so might cause faulty operation.
	Do not disassemble the DMC10. Doing so might cause faulty operation.
	Use the DMC10 within the operating ranges (temperature, humidity, vibration, shock, mounting direction, atmosphere, etc.) recommended in the specifications. Failure to do so might cause fire or faulty operation.
	Do not block ventilation holes. Doing so might cause fire or faulty operation.
	Wire the DMC10 properly according to predetermined standards. Also wire the DMC10 using designated power supply according to recognized installation methods. Failure to do so might cause electric shock, fire or faulty operation.
	Do not allow lead clippings, chips or water to enter the DMC10 case. Doing so might cause fire or faulty operation.
	Firmly tighten the terminal screws at the torque listed in the specifications. Insufficient tightening of terminal screws might cause fire.
	Do not use unused terminals on the DMC10 as relay terminals. Doing so might cause electric shock, fire or faulty operation.
	Use Yamatake Corporation's SurgeNon if there is the risk of power surges caused by lightning. Failure to do so might cause fire or faulty operation.
	When disposing of the DMC10, dispose of it appropriately as industrial waste in accordance with local bylaws and regulations.
	Use the relay on the DMC10 within the rated life described in the specifications. Continued use of the DMC10 outside of the rated life might cause fire or faulty operation.
	The DMC10 will not function for about ten seconds after turning the power ON. Pay attention to this when using the relay output from the DMC10 as an interlock signal.
	Prevent the total power consumption of all linked modules from exceeding 100W.
	Do not supply power from two or more lines to all linked modules. Doing so might cause fire or faulty operation.
	Do not short the control output section (at voltage pulse output). Doing so might activate the overcurrent protection circuit for the internal power supply, and reset the DMC10.

Unpacking

Check the following when removing the **SLP-D10** from its package:

1. Check the model No. to make sure that you have received the product that you ordered.
2. Check the **SLP-D10** for any apparent physical damage.
3. Check the contents of the package against the Package List to make sure that all accessories are included in the package.

After unpacking, handle the **SLP-D10** and its accessories taking care to prevent damage or loss of parts.

If an inconsistency is found or the package contents are not in order, immediately contact your dealer.

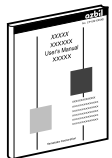
Name	Model No.	Qt'y	Remarks
Smart Loader Package SLP-D10 System disk 	SLP-D10J50	1	CD-ROM
Special cable (1 set)	—	1	
User's Manual 	CP-UM-5143	1	Japanese version
	CP-UM-5143E	1	This manual. English version
User Registration Card		1	Enter the required particulars in the User Registration Card and return it to us immediately. Otherwise, you will not receive notification of version upgrades and we will not be able to provide the necessary support in response to your inquiries.

The Role of This Manual

In all, 3 manuals have been prepared for the **DMC10**. Read the manual according to your specific requirements. The following lists all the manuals that accompany the **DMC10** and gives a brief outline of the manual. If you do not have the required manual, contact Yamatake Corporation or your dealer.

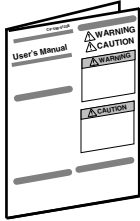

DMC10S/DMC10D Distributed Multi-channel Controller Manual No.CP-UM-5126E

This manual is packaged with the DMC10S or DMC10D.

This manual describes only the precautions when using the DMC10S and DMC10D, their specifications and how to wire.

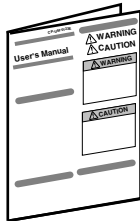

DMC10E Distributed Multi-channel Controller Manual No.CP-UM-5131E

This manual is packaged with the DMC10E.

This manual describes only the precautions when using the DMC10E, its specifications and how to wire.

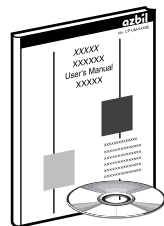

DMC10D Distributed Multi-channel Controller and SLP-D10 Smart Loader Package Manual No.CP-UM-5143E

This manual.

This manual is supplied with the Smart Loader Package SLP-D10 system disk.

This manual describes the product body and the exclusive SLP-D10. This manual describes an outline of the DMC10, how to install the DMC10 for building it into instrumentation, how to wire, maintenance and inspection, how to remedy trouble that may occur, function specifications, how to install the Smart Loader Package SLP-D10, operations on the personal computer, each of the functions and how to setup.

Organization of This User's Manual

This manual is organized as follows:

Chapter 1. INTRODUCTION

This chapter describes a brief outline of the **DMC10** and the product model numbers.

Chapter 2. NAMES & FUNCTIONS OF PARTS

This chapter describes the names and functions of parts on the **DMC10**.

Chapter 3. INSTALLATION

This chapter describes installation sites for the **DMC10** and how to install the **DMC10**.

Chapter 4. WIRING

This chapter describes how to wire the **DMC10**, how to connect the power supply and how to connect for RS-485 communications.

Chapter 5. DEVICE CONNECTIONS & CONFIGURATION

This chapter describes the configuration of the **DMC10** system and the product model numbers.

Chapter 6. SETUP & OPERATIONS

This chapter describes overall operation methods for running the **DMC10**.

Chapter 7. LOADER

This chapter describes how to operate the Smart Loader Package **SLP-D10** exclusively for the **DMC10**.

Chapter 8. SETUP PARAMETERS (Common to DMC10S and DMC10D)

This chapter lists setup parameter tables and describes each function in detail.

Chapter 9. SETUP PARAMETERS (DMC10D)

This chapter describes additional setup parameters relating to the **DMC10D** only in detail.

Chapter 10. COMMUNICATIONS FUNCTIONS

This chapter describes how to communicate with a personal computer, PLC or other host devices.

Chapter 11. MODBUS COMMUNICATIONS FUNCTIONS

This chapter describes how to communicate with a personal computer, PLC or other host devices through MODBUS communications.

Chapter 12. ADJUSTMENT & ZENER BARRIER ADJUSTMENT

This chapter describes how to adjust the **DMC10** and the adjustment procedure.

Chapter 13. TROUBLESHOOTING

This chapter describes how to find the cause of trouble that occurs when using the **DMC10** and how to remedy trouble.

Chapter 14. SPECIFICATIONS

This chapter describes the general specifications, performance specifications and external dimensions of the **DMC10**.

Appendix

This appendix provides advice for methods of use.

Contents

SAFETY PRECAUTIONS

Unpacking

The Role of This Manual

Organization of This User's Manual

Conventions Used in This Manual

Chapter 1. INTRODUCTION

- Features.....1-1
- Model Selection Guide1-2

Chapter 2. NAMES & FUNCTIONS OF PARTS

- Body.....2-1
- Base2-2

Chapter 3. INSTALLATION

- Mounting Locations.....3-1
- Linking Modules3-1
- Installation Procedure3-1
- Mounting the Body on the Base.....3-2

Chapter 4. WIRING

- Wiring.....4-1
- Wiring Precautions4-4
- Connecting the Power Supply.....4-6
- Connecting for CPL Communications.....4-6
- Connecting to the SSR.....4-7

Chapter 5. DEVICE CONNECTIONS & CONFIGURATION

- Number of Connected Units5-1
- Setting the Device Address5-2
- Configuration When Combined With the CMC105-3
- Layout of Event Output Module DMC10E.....5-4

Chapter 6. SETUP & OPERATIONS

- Overall Operation Procedure.....6-1
- Setup Method6-1

Chapter 7. LOADER

- 7-1 Introduction.....7-1
 - Loader Functions.....7-1
 - System Operating Environment.....7-2
- 7-2 Installing, Starting up and Quitting the Software Package.....7-3
 - Installation.....7-3
 - Device Driver Installation for USB Loader Cable.....7-6
 - Starting Up SLP-D10.....7-10

	■ Quitting SLP-D10	7-10
7-3	Setup Function.....	7-11
	■ Outline of Setup Function.....	7-11
	■ Screen Explanations	7-11
	■ Operation Procedure	7-13
7-4	Monitor Function	7-17
	■ Outline	7-17
	■ Screen Explanations	7-18
	■ How to Operate the Numeric Monitor Screen	7-19
	■ How to Operate the Trend Monitor.....	7-21

Chapter 8. SETUP PARAMETERS (Common to DMC10S and DMC10D)

8-1	List of Setup Parameters	8-1
	■ Basic Functions	8-1
	■ Option Functions	8-3
8-2	Explanation of Basic Functions	8-5
	■ PV Input	8-5
	■ Control Output	8-8
	■ SP and Control Parameters	8-12
	■ Communications.....	8-13
	■ Other	8-14
8-3	Detailed Explanation of Option Functions	8-16
	■ Event Output	8-16
	■ Current Transformer Input.....	8-25
	■ External Switch Input	8-26
	■ Auxiliary Output (current output).....	8-29
8-4	Event Output Special Operation.....	8-30
	■ Setup Parameters (only for event output special operation)	8-30
	■ Detailed Explanation	8-31
8-5	External Switch Input Special Operation.....	8-33
	■ Setup Parameters (only external switch input special operations).....	8-33
	■ Detailed Explanation	8-33

Chapter 9. SETUP PARAMETERS (DMC10D)

9-1	Outline of the Advanced Functions	9-1
	■ PV Input	9-1
	■ Control Output	9-1
9-2	Detailed Explanation of Basic Functions	9-3
	■ Heat/Cool Output Assignments.....	9-3
	■ Inter-channel Deviation Control	9-4
	■ Control by Remote SP.....	9-5
	■ Position Proportional Control	9-6
	■ Time Proportional Power Saving Mode	9-11
	■ MV Branch Control	9-14

Chapter 10. COMMUNICATIONS FUNCTIONS

10-1	Outline of Communications.....	10-1
------	--------------------------------	------

■ Features.....	10-1
■ Defaults.....	10-1
■ Communications Procedures.....	10-2
10-2 Message Structure.....	10-3
■ Message Structure.....	10-3
■ Data Link Layer.....	10-3
■ Application Layer.....	10-5
10-3 Description of Commands.....	10-6
■ Read Continuous Data Command (RS command).....	10-6
■ Write Continuous Data Command (WS command).....	10-7
■ Read Continuous Fixed Length Data Command (RD command).....	10-8
■ Write Continuous Fixed Length Data Command (WD command).....	10-9
■ Read Fixed Length Random Data Command (RU command).....	10-10
■ Write Fixed Length Random Data Command (WU command).....	10-11
10-4 Definition of Word Addresses.....	10-12
10-5 How Numerical Values Are Expressed in the Application Layer.....	10-13
10-6 List of Status Codes.....	10-14
10-7 Reception and Transmission Timing.....	10-15
■ Timing Specifications for Instruction and Response Message.....	10-15
■ RS-485 Driver Control Timing Specifications.....	10-15
10-8 List of All Communications Parameters (in RAM address order).....	10-16
■ Word Address Data.....	10-16
■ Bit Information Data.....	10-30
10-9 Detail Explanation on Communication Conditions.....	10-39
■ Write Conditions.....	10-39
■ Write Range.....	10-40
■ Constant Write Inhibit.....	10-41
10-10 Cautions When Making Communications Programs for the Master Station ...	10-42

Chapter 11. MODBUS COMMUNICATIONS FUNCTIONS

11-1 Outline of Communications.....	11-1
■ Features.....	11-1
■ Initial Setting.....	11-1
■ Communications Procedures.....	11-1
11-2 Message Structure.....	11-2
■ Message Structure.....	11-2
■ Transmission Message.....	11-4
■ Response Time.....	11-4
■ Other Specifications.....	11-4
11-3 Description of Commands.....	11-5
■ RTU Encoding.....	11-5
■ ASCII Encoding.....	11-6

Chapter 12. ADJUSTMENT & ZENER BARRIER ADJUSTMENT

■ Precautions before Adjustment.....	12-1
■ Measurement Equipment Required for Adjustment.....	12-1
■ Adjustment Procedure.....	12-1
■ About Zener Barrier Adjustment.....	12-5

Chapter 13. TROUBLESHOOTING

- How to Use the LEDs on the Front Panel When Checking Alarms13-1
- PV Input Related Trouble13-2
- Body Alarms Related Trouble13-2
- Loader Communications Related Trouble13-3
- Host Communications Related Trouble13-3
- Control Related Trouble.....13-4

Chapter 14. SPECIFICATIONS



- 14-1 General Specifications14-1
 - Environmental Conditions14-1
- 14-2 Performance Specifications14-2
 - PV Input14-2
 - Isolation Between Inputs and Outputs14-6
 - External Dimensions14-6

Appendix

- 1. Advice on Control ConstantsApp-1
 - ON/OFF ControlApp-1
 - Control by Self-tuningApp-1
 - Control by PID Fixed ValuesApp-2
- 2. Advice on EventsApp-3
- 3. Event Output Special OperationApp-5
 - Internal Structure of Event Output Special OperationApp-5
 - Block Diagram of Output Special OperationApp-6
 - Operating Procedures for Event Output Special OperationApp-7
- 4. External Switch Input Special OperationApp-10
 - Internal Structure of External Switch Input Special OperationApp-10
 - Operating Procedures for RSW Input Special OperationApp-12
 - Sample Applications Combining the Event Output Special Operation and the RSW Special Operation
- 5. Settings When Heat/Cool Control Is UsedApp-15
 - Setting ProceduresApp-15
- 6. Settings When Remote SP Is UsedApp-16
 - Setting ProceduresApp-16
- 7. Settings When Inter-Channel Deviation Control Is UsedApp-17
 - Setting ProceduresApp-17

Conventions Used in This Manual

The following conventions are used in this manual:

-  **Handling Precautions** : Handling Precautions indicate items that the user should pay attention to when handling the **DMC10**.
-  **Note** : Notes indicate useful information that the user might benefit by knowing.
- (1), (2), (3) : The numbers with the parenthesis indicate steps in a sequence or indicate corresponding parts in an explanation.
- [Open] button : Indicates a selection button in screens displayed on the personal computer.
-  : Indicates icon buttons displayed on the personal computer.
- [SLP-D10.exe],
[Printing],
[Open file] : Indicate messages and menus displayed on the personal computer.
- ▶ : Indicates the result of an operation, details displayed on the personal computer or devices, or the state of a device after an operation.
- [Tab] key, [F4] key : Indicates keys on the keyboard.
- [Ctrl] + [T] key : Indicates the operation of pressing the [T] key with the [Ctrl] key on the keyboard held down.
- (minus) to + (plus) : This manual expresses numerical value ranges using – (minus) and + (plus), for example as –10 to +100, when expressing a range starting with a minus value.

Ranges are not expressed using a + (plus) when the range starts from a plus value for example as 0 to 1000.

Data specified in transmission and reception in communications need not be prefixed with + (plus). An error occurs if data is prefixed with the + (plus) symbol.

Chapter 1. INTRODUCTION

■ Features

- This modular is provided with 2-loop or 4-loop control functions on each single unit.
- Input types are thermocouples (K, J, E, T, R, S, DIN U, DIN L), resistance temperature detector (Pt100, JPt100), current signals (4 to 20mA_{dc}), and voltage signals (0 to 1V_{dc}, 0 to 5V_{dc}, 1 to 5V_{dc}). Each of these input types can be designated to each channel. This allows different inputs to be combined on a single controller.

Each of the channels is isolated, eliminating worry of trouble caused by rerouting circuits.

- Control output types are relay and voltage pulse, and control types are ON/OFF control, self-tuning control and control by fixed PID.
- Optional functions for the 2-channel model include current transformer input used for the heater line break alarm; upper/lower limit alarm or heater line break alarm; event output that can be used as a delay timer; RUN/READY or AUTO/MANUAL mode switching; external switch input that can be used as a function for switching four setting values; and current output (AUX) that enables input of PV value trends to a recorder. Select the option to suit your particular control requirements. (Optional functions cannot be added on to 4-channel models.)
- Use of the event output module (sold separately) enables use of event output even on 4-channel modules.
- Connection of the link connector on the side of the DMC10 and relay terminals provided on the base enable connection to up to 15 modules.
- The DMC10 has not display or setup unit. This allows it to be designed in a compact size (30mm (W) x 100mm (H) x 110mm (D)).
- The DMC10 can be mounted on DIN rail or screw-mounted on walls. This facilitates mounting on panels or instrumentation.
- The DMC10 Smart Loader Package (sold separately) is supported on PC/AT compatible personal computers (Windows OS).
- Parameters can be read and written easily on the DMC10 Smart Loader Package (sold separately).

In addition to setting the table format, operations while the DMC10 is running and monitoring of the control state on the trend screen are possible. This enables operation of the DMC10 without the need for a program on the host device.

- With the advanced function model DMC10D, heat/cool control, inter-channel deviation control, remote SP input, position proportional control and power saving functions can also be used in addition to the above functions.
- The DMC10 conforms to IEC directives, and has acquired CE marking. (applicable standard: EN61010-1, EN50081-2, EN50082-2)
When the CE standard is to be acquired on the instrumentation, use a third-party 24V_{dc} power supply that has CE marking.

■ Model Selection Guide

● Configuration of DMC10S, DMC10D model numbers

Basic Model No.	Number of Channels	Wiring Method	Control Output	Options	Additional Processing	Specifications
DMC10S						Standard model *1
DMC10D						Advanced function model
	2					2-channel input *2
	4					4-channel input *3
		T				Terminal wiring
		C				Connector wiring
			R			Relay output
			V			Voltage pulse output (for SSR drive)
				00		None
				01		2 CT inputs, 4 event relay outputs
				02		2 CT inputs, 4 external switch inputs
				03		2 AUX outputs, 4 event relay outputs
				04		2 AUX outputs, 4 external switch inputs
				05		2 CT inputs, 2 event relay outputs, 2 event voltage outputs
				06		2 CT inputs, 2 external switch inputs, 2 event voltage outputs
				00		None
				D0		Inspection Certificate provided
				Y0		Complying with the traceability certification

*1: When the standard model is selected, you cannot select options "05" and "06".

*2: When 2-channel input is selected, option "00" cannot be selected.

*3: When 4-channel input is selected, option "00" is fixed.

● List of DMC10 related products

Model No.	Specifications
DMC10E4CR0000	Event output module (4-channel relay output)
SLP-D10J50	Smart Loader package for DMC10 (including special cable)
81440792-001	Connector set (pack of 4, MSTB2, 5/5-STF-5, 08AU made by Phoenix Contact)
SDU10T0100	For Distributed Multi-Channel Controller DMC10

● List of CMC10 related products

Model No.	Specifications
CMC10ACL1A000	Communications Controller CC-Link/CPL converter
CMC10BCP1A000	Communications Controller CPL/CPL Converter
CMC10G	Communication Controller (PLC/Controller Converter)
CMC10L001A000	RS-232C/RS-485 converter
SLP-CM1E20	Smart Loader package for CMC10B (including special cable)
81446717-001 *	Terminating resistor (110Ω, 2 p'ces) for CMC10A
81446717-002 *	Terminating resistor (130Ω, 2 p'ces) for CMC10A
81446748-001	AC adapter for CMC10L
81440792-001	Connector set (pack of 4, MSTB2, 5/5-STF-5, 08AU made by Phoenix Contact)

*: Connect this terminating resistor to both of the units that are at either end of the CC-Link. However, please note that the specifications of the terminating resistor vary depending on the cable used for the CC-Link. For more information on the terminating resistor, refer to:

- Mitsubishi Electric CC-Link System Master Local Unit User's Manual (currently being revised)
- Mitsubishi Sequencer Technical News (No.PLC-D-330).

Chapter 2. NAMES & FUNCTIONS OF PARTS

■ Body

● DMC10S, DMC10D

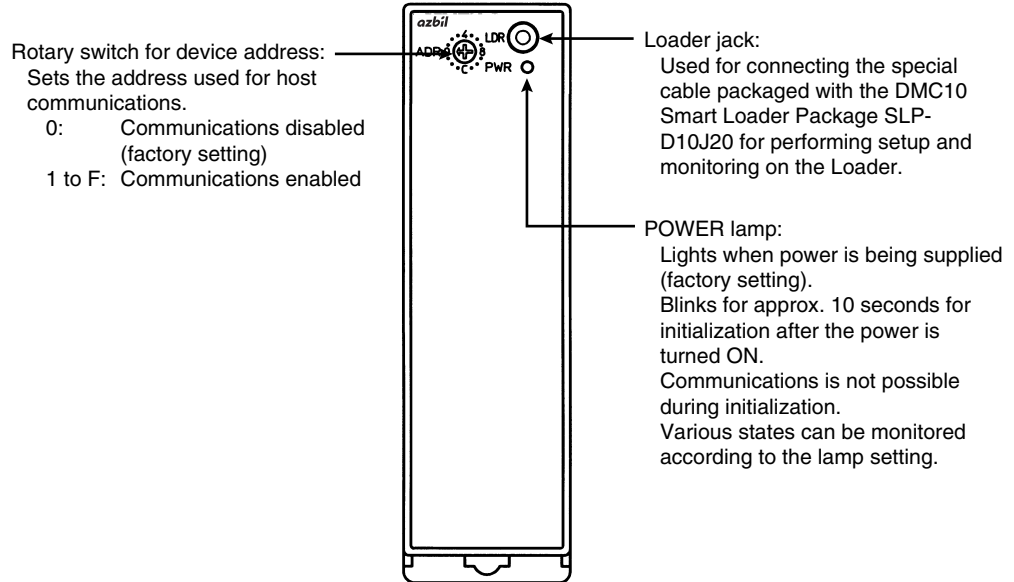

● DMC10E

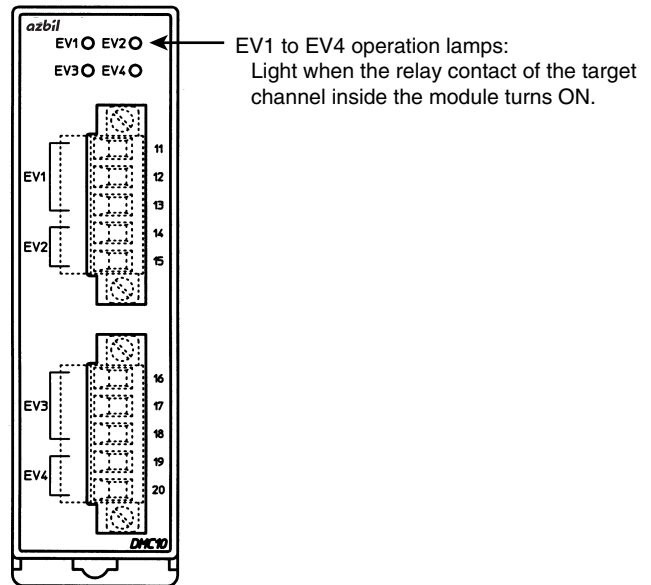

📖 Note

The compatible connector for the DMC10S and DMC10D connector wiring models and the DMC10E is part No. 81440792-001 (4 pc's/set). This is an equivalent product of MSTB2, 5/5-STF-5, 08AU made by Phoenix Contact.

■ Base

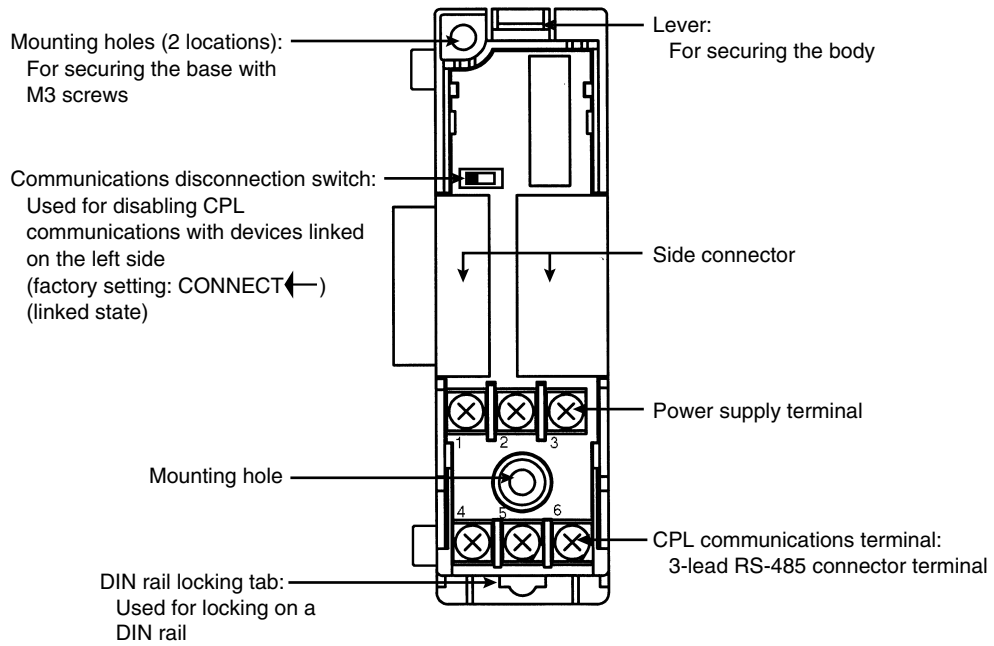

Chapter 3. INSTALLATION

⚠ CAUTION



Use the DMC10 within the operating ranges (temperature, humidity, vibration, shock, mounting direction, atmosphere, etc.) recommended in the specifications.

Failure to do so might cause fire or faulty operation.



Do not block ventilation holes.

Doing so might cause fire or faulty operation.

■ Mounting Locations

Avoid installing the DMC10 in the following locations:

- Locations subject to low and high temperature and humidity exceeding the specified ranges
- Locations subject to corrosive gases such as sulfide gases
- Locations subject to dust or oil smoke
- Locations subject to direct sunlight, wind or rain
- Locations subject to vibration or shock exceeding the specified ranges
- Locations under high-voltage lines and near sources of electrical noise such as welders
- Locations within 15 meters of high-voltage ignition equipment such as boilers
- Locations where magnetic fields are generated
- Locations near flammable liquid or steam

■ Linking Modules

The DMC10 can be linked with other modules by the connectors on the left and right of the base. Modules must be linked before the DMC10 is mounted on the DIN rail or mounted by screws. By linking modules together, the power supply of each module and CPL communications are connected, eliminating the need for wiring. CPL communications can be disconnected by the communications disconnection switch on the base.

■ Installation Procedure

The DMC10 can be mounted in either of two ways, by mounting its base by screws or by securing on a DIN rail.

- Mount each DMC10 module vertically as in the figure below.

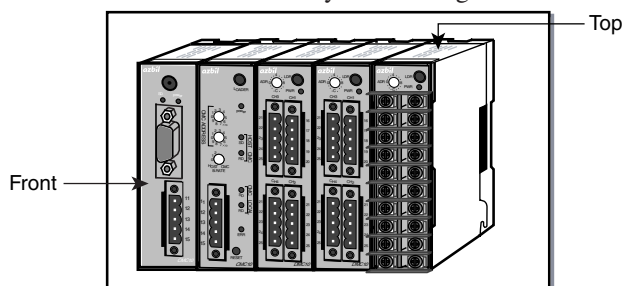

Handling Precautions

- Mount the DMC10 modules in the same horizontal plane. Deviation from the horizontal should not exceed the amount stated in the specifications.

- Do not mount as shown below.

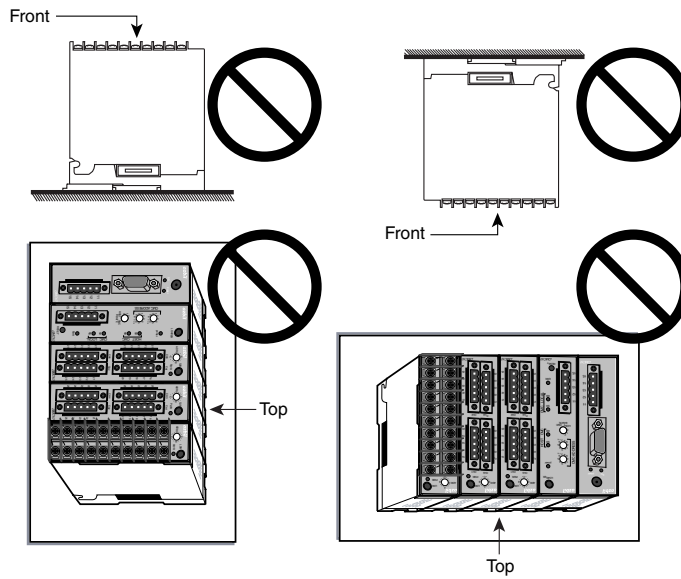

- When mounting the base by screws

Secure the two mounting holes on the base by M3 screws.

Unit: mm

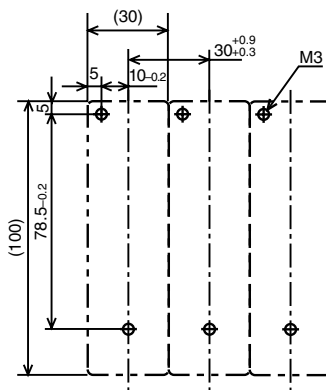

- When securing on a DIN rail

Secure the DMC10 on the DIN rail, fully draw out the DIN rail locking tab and hook the base onto the DIN rail. Next, push the DIN rail locking tab upwards until you hear it click into place.

■ Mounting the Body on the Base

Fit the hook into the base and push the body into the base until you hear it click into place. To remove the body from the base, pull the body towards you while pressing down the lever.

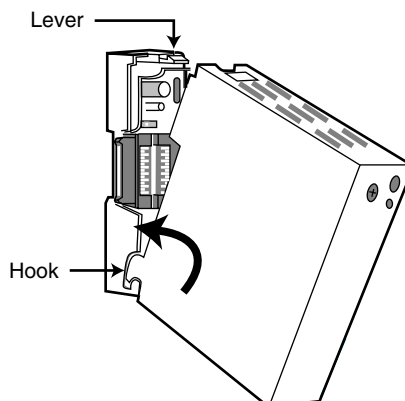

Chapter 4. WIRING

⚠ CAUTION

- ❗ Before wiring or installing the DMC10, be sure to turn the power OFF. Failure to do so might cause faulty operation.
- ❗ Wire the DMC10 properly according to predetermined standards. Also wire the DMC10 using designated power supply according to recognized installation methods. Failure to do so might cause electric shock, fire or faulty operation.
- ❗ Firmly tighten the terminal screws at the torque listed in the specifications. Insufficient tightening of terminal screws might cause fire.
- ⊘ Do not use unused terminals on the DMC10 as relay terminals. Doing so might cause electric shock, fire or faulty operation.

■ Wiring

● 2-channel model

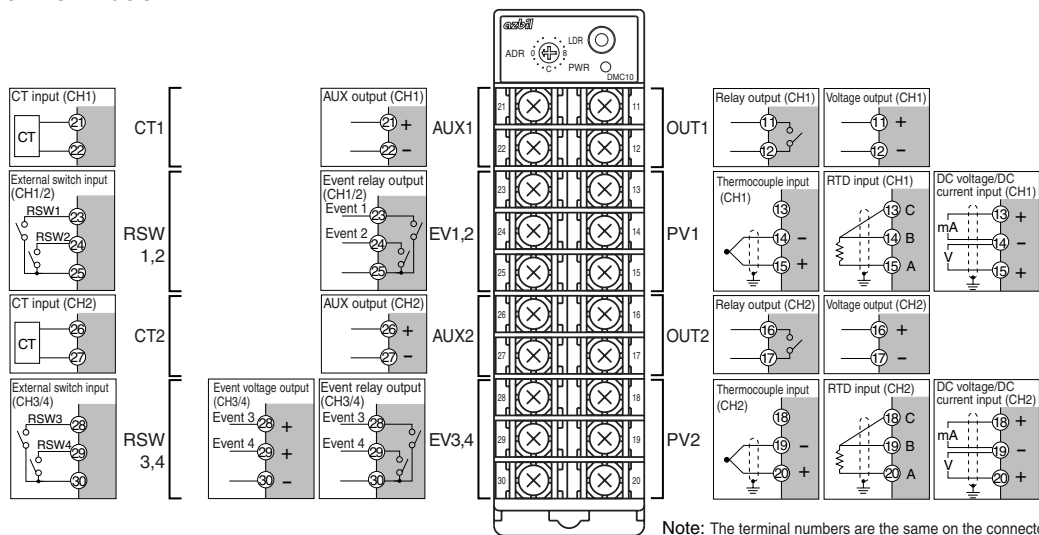

● 4-channel model

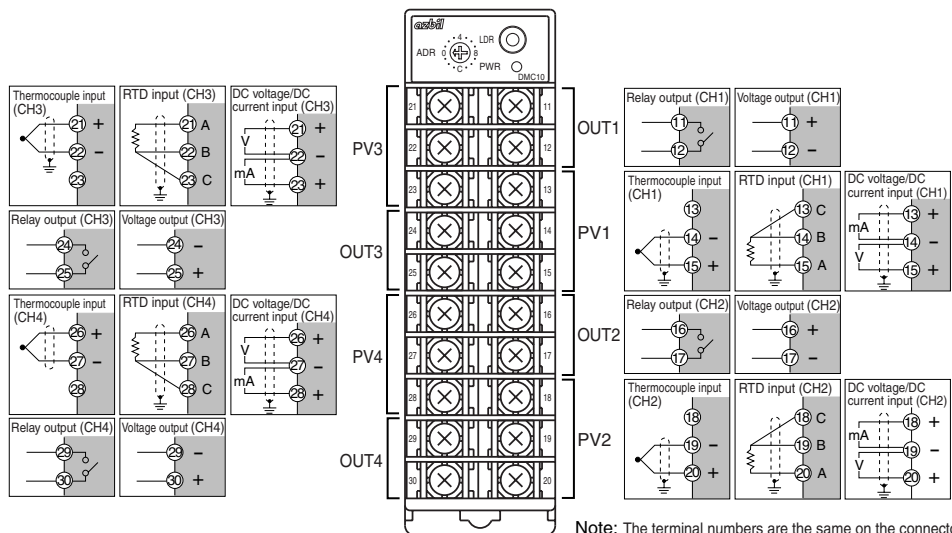

● Heat/cool model (2-channel model)

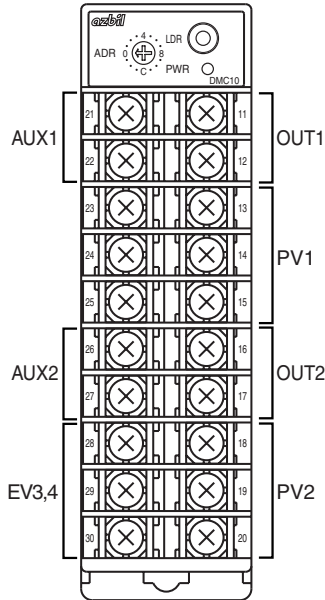

In the heat/cool control, it is necessary to set up the outputs of each loop. The settings vary according to the model. There is no heat/cool model among the 4-channel models.

The relationship between the settings and the output specifications is shown below.

The settings shown below become effective only after collectively being written by the loader.

Setting	Operating terminal type	CH1 output port	CH2 output port	Available models	Remarks
0	Heat: Relay	OUT1	OUT2	<ul style="list-style-type: none"> DMC10D2XR01X0 DMC10D2XR03X0 	-
	Cool: Relay	EV3	EV4		
1	Heat: Voltage	OUT1	OUT2	<ul style="list-style-type: none"> DMC10D2XV01X0 DMC10D2XV03X0 	-
	Cool: Relay	EV3	EV4		
2	Heat: Relay	EV3	EV4	<ul style="list-style-type: none"> DMC10D2XV01X0 DMC10D2XV03X0 	-
	Cool: Voltage	OUT1	OUT2		
3	Heat: Voltage	EV3	EV4	<ul style="list-style-type: none"> DMC10D2XR05X0 DMC10D2XR06X0 	-
	Cool: Relay	OUT1	OUT2		
4	Heat: Relay	OUT1	OUT2	<ul style="list-style-type: none"> DMC10D2XR05X0 DMC10D2XR05X0 	-
	Cool: Voltage	EV3	EV4		
5	Heat: Voltage	OUT1	OUT2	<ul style="list-style-type: none"> DMC10D2XV05X0 DMC10D2XV06X0 	-
	Cool: Voltage	EV3	EV4		
6	Heat: Relay	OUT1	OUT2	<ul style="list-style-type: none"> DMC10D2XR03X0 DMC10D2XR04X0 	-
	Cool: Current	AUX1	AUX2		
7	Heat: Current	AUX1	AUX2	<ul style="list-style-type: none"> DMC10D2XR03X0 DMC10D2XR04X0 	-
	Cool: Relay	OUT1	OUT2		
8	Heat: Voltage	OUT1	OUT2	<ul style="list-style-type: none"> DMC10D2XV03X0 DMC10D2XV04X0 	-
	Cool: Current	AUX1	AUX2		
9	Heat: Current	AUX1	AUX2	<ul style="list-style-type: none"> DMC10D2XV03X0 DMC10D2XV04X0 	-
	Cool: Voltage	OUT1	OUT2		
10	Heat: Current	AUX1	-	<ul style="list-style-type: none"> DMC10D2XX03X0 DMC10D2XX04X0 	One-loop control only
	Cool: Current	AUX2	-		

Note: The Xs in the numbers of the available models indicate that any applicable functional code is acceptable.

● Position proportional model (2-channel model)

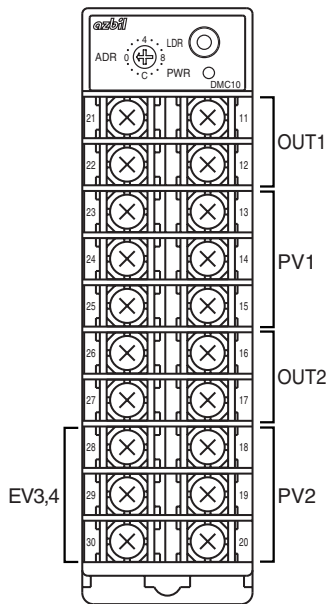

The position proportional control function allows you to use the DMC10 as a position proportional controller for one channel or two channels.

The output terminal assignment shown below becomes effective only after

Available models	Position proportional CH No.	PV	Feedback input	OPEN	CLOSE	Remarks
DMC10D2XRXXX	CH1	PV1	PV2	OUT1	OUT2	With feedback
	CH2	–	–	–	–	
DMC10D2XR01X DMC10D2XR03X	CH1	PV1	–	OUT1	OUT2	Without feedback
	CH2	PV2	–	EV3	EV4	

collectively being written by the loader.

Note: The Xs in the numbers of the available models indicate that any applicable functional code is acceptable.

! Handling Precautions

- Make sure to use the auxiliary relay for driving the motor.
- When the DMC10 is set so that the position proportional control is used with feedback, the PV input channel is used for feedback input. (See above.)

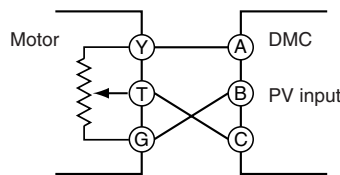

- Connect the motor as follows:
- When the position proportional channel 2 is not used, it is also allowed to use EV3 and EV4 as the normal EVENT terminals by changing the event special output operation (assignment of output terminals).
- When the position proportional channel 2 is not used, it is also allowed to select the model number DMC10D2XRXXX.
- It is not allowed to change the feedback input channel.

● Position proportional model (4-channel model)

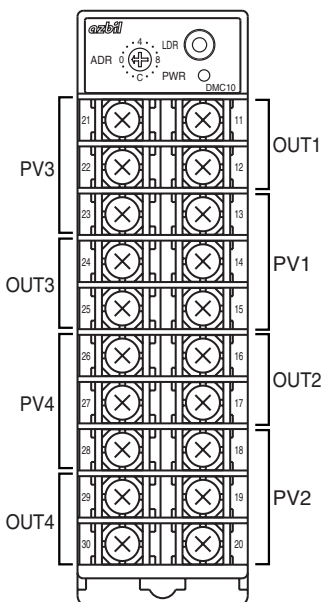

Available models	Position proportional control CH No.	PV	Feedback input	OPEN	CLOSE	Remarks
DMC10D4XRXXX	CH1	PV1	PV3	OUT1	OUT3	With feedback
	CH2	PV2	PV4	OUT2	OUT4	
DMC10D4XRXXX	CH1	PV1	–	OUT1	OUT3	Without feedback
	CH2	PV2	–	OUT2	OUT4	

Note: The Xs in the numbers of the available models indicate that any applicable functional code is acceptable.

● DMC10E

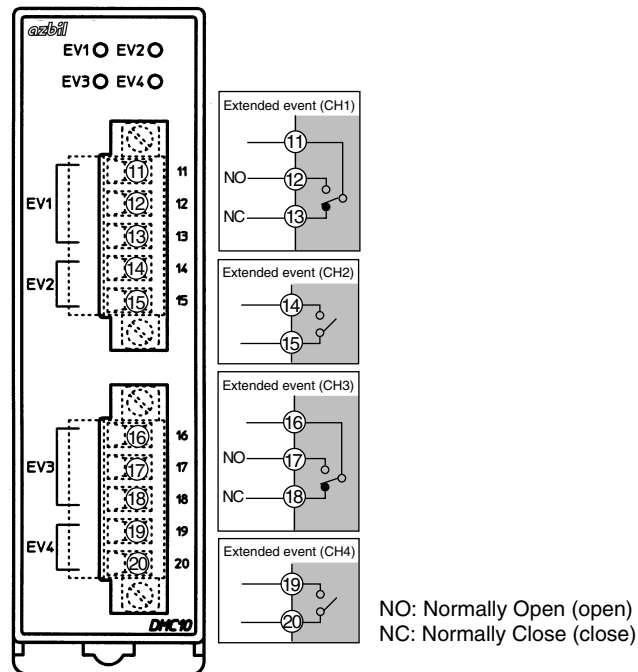

■ Wiring Precautions

CAUTION
The DMC10 will not function for about ten seconds after turning the power ON. Pay attention to this when using the relay output from the DMC10 as an interlock signal.

- Check the model number of the controller and terminal numbers on the label on the side of the controller to prevent any wiring errors.
- Use crimped terminals for M3.5 screws to connect terminals.
- Prevent crimped terminals from coming into contact with adjacent terminals.
- I/O signal lines should be routed at least 50cm away from power lines. Also, do not route I/O leads through the same distribution box or ducts.
- Before connecting in parallel to other equipment, thoroughly check the conditions of the other equipment.
- Pass a lead wire for carrying the heater current through a current transformer. Do not use a heater current that exceeds the allowable current described in the specifications. Doing so might damage the DMC10.
- The controller is designed not to function for ten seconds after the controller is turned ON. This is to allow it to stabilize. The controller then enters the Run mode. However, allow at least 30 minutes for the controller to warm up so that the specified accuracy is satisfied.
- When wiring is finished, check the connections for any miswiring before turning the power ON.

- **Wiring connectors (81440792-001: sold separately)**

- Specifications of cable used

Lead type: Single lead or twisted
 Lead size: 0.2 to 2.5mm² (AWG28 to 12)
 Ideal exposed lead length: 7mm

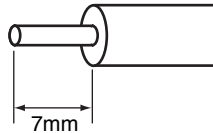

- Screw tightening torque

Connector terminal: 0.5 to 0.6 N·m
 Connector mount: 0.5 to 0.6 N·m

- Specifications of recommended screwdriver

We recommend using a screwdriver matched to the connector screw to firmly fasten the cable.

Manufacturer: Phoenix Contact
 Model No.: SZS0.6 x 3.5



Note

- Crimped terminal

Generally, use a sleeve for the crimped terminal to mark each of the cables. The following shows crimped terminals matched to this connector for reference purposes.

Manufacturer: J.S.T Mfg Co., Ltd.

Model No.: VTUB-1.25

(pack of 1000, w/ insulated covering, lead size: 0.25 to 1.65mm²)

VTUB-2

(pack of 1000, w/ insulated covering, lead size: 1.04 to 2.63mm²)

TUB-1.25

(pack of 1000, w/out insulated covering, lead size: 0.25 to 1.65mm²)

TUB-2

(pack of 1000, w/out insulated covering, lead size: 1.04 to 2.63mm²)

■ Connecting the Power Supply

⚠ CAUTION



Prevent the total power consumption of all linked modules from exceeding 100W.

Connect the power terminal as follows:
 Power is mutually connected between linked modules.
 Supply power to one of the linked modules.

No.□	Signal□
1□	24Vdc (+)□
2□	24Vdc (-)□
3□	Do not use

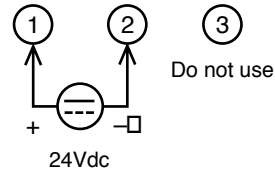

The power supply unit must be a UL approved Class 2 power supply unit or Class 2 transformer in order to apply UL.

ⓘ Handling Precautions

Select a power supply that can cover the total power consumption of all linked modules.

■ Connecting for CPL Communications

CPL communications (RS-485) is performed using a 3-lead connection.
 Connect to one of the linked modules for communications.

No.□	Signal□
4□	DA□
5□	DB□
6□	SG□

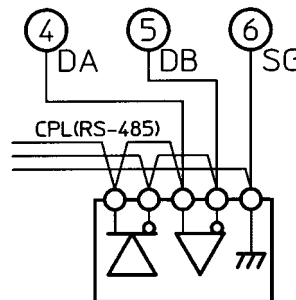

ⓘ Handling Precautions

- Do not connect an external terminating resistor as the DMC10 has a built-in resistor equivalent to a terminator.
- Do not connect a terminating resistor when setting an SDC series, DCP series or SRF series product (made by Yamatake Corporation) to the same communications line.
- Be sure to connect SG terminals each other.
 Failure to do so might cause unstable communications.

■ Connecting to the SSR

Up to 3 DMC10s can be connected in series to the main SSR.
 Note, however, that connection is subject to conditions.

- When connecting to a PGM (made by Yamatake Corporation)

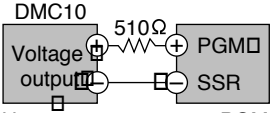
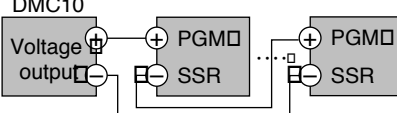
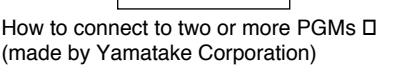
Number of SSR Units	Connection Conditions	Remarks
1	External resistors of 510Ω (consumption current 1/2W or more) are required in series.	 <p>How to connect to one PGM □ (made by Yamatake Corporation)</p>
2	Series connection	
3	Series connection	 <p>How to connect to two or more PGMs □ (made by Yamatake Corporation)</p>

The following shows an example of how to calculate when the DMC10 is connected to two units of the PGM (made by Yamatake Corporation):

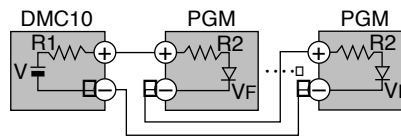

V: □ 13V±5% □

R1: □ 50Ω±5% □

R2: □ 60Ω □

VF: □ 1.2V

$$\text{Voltage between PGM terminals} = \frac{(V - 2 \times VF) \square}{R1 + 2 \times R2} \times R2 + VF$$

$$\approx 5.3V$$

Allowable voltage between PGM terminals: □

In the above connection, operation is possible within 3 to 6V.

- When connecting to a PGM10N/F (made by Yamatake Corporation)

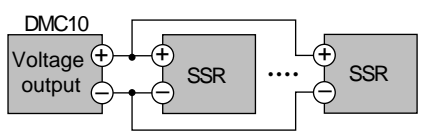
Number of SSR Units	Connection Conditions	Remarks
1		
2	Parallel connection	
3	Parallel connection (PGM10N only)	

The following shows an example of how to calculate when the DMC10 is connected to the PGM10N015 (made by Yamatake Corporation):

- Max. input current of SSR \leq Allowable max. current of voltage pulse output. This relation must be satisfied.
 Since the input current is 10mA or less, $10\text{mA} \times 3 \text{ units} = 30\text{mA}$.
 This is less than the allowable max. current 30mA of voltage pulse output.
 Therefore, 3 units can be driven.
- The input voltage range of SSR must be within the range of voltage between terminals of voltage pulse output.
 $13\text{V} \pm 5\%$ (voltage between terminals of output) - $150\Omega \pm 5\%$ (internal resistance) $\times 30\text{mA}$ (driving current for 3 units) ≈ 7.5 to 9.5V .
 This is within the input voltage range 3.5 to 30V of SSR.
 Therefore, 3 units can be driven.

- When connecting to a G3PA (made by Omron Corporation)

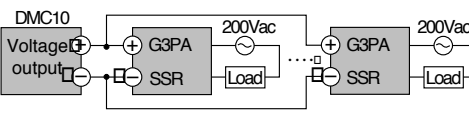
Number of SSR Units	Connection Conditions	Remarks
1		
2	Parallel connection	
3	Parallel connection	

Chapter 5. DEVICE CONNECTIONS & CONFIGURATION

■ Number of Connected Units

● When connecting 15 or less units

Up to 15 DMC10s can be connected directly to a single host device (personal computer, programmable display device, PLC).

Note

The following shows a guideline of the time required for communications:
Communications time = {(number of data items per unit) x 3.3ms + 27ms} x number of connected units

Note, however, that this value is a reference value that includes processing time on the host (Windows98, Pentium III 800MHz) when a Yamatake host test program is used at a transmission speed of 19200bps.

When 15 units of 4-channel model is multi-dropped under the above conditions, and also “PV of each device=4ch X 15 units (PV amount of 60 channels)” is read out,

- Use of Yamatake CMC10L for RS-232C/RS-485 conversion
- Communication command: RD03EA0004 (PV is read out for 4-channels on each device)

In this case, the communication completes in approx. 600ms.

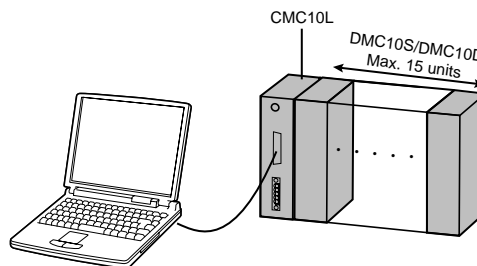

This value may vary considerably according to the operation content of the host device, content of communications with the DMC10, setup and commands used. The CMC10L is a converter for converting between RS-232C to RS-485 communications.

This converter is not required when the host device has a 3-lead RS-485 communications port.

● When connecting 16 or more units

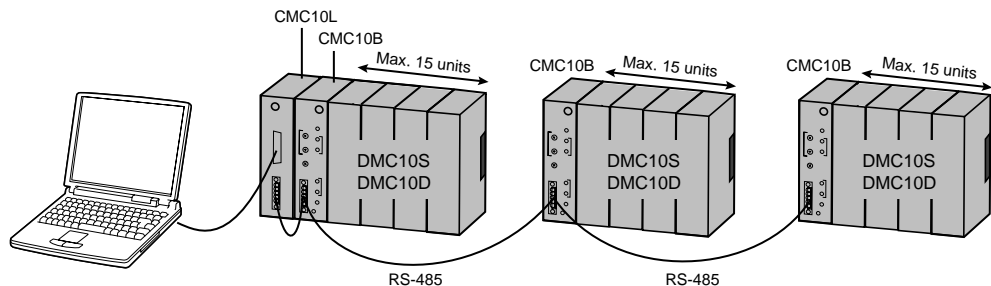

The communications converter CMC10B (sold separately) is needed to connect 16 or more DMC10s.

Note

The CMC10B allows up to 31 DMC10s to be connected to a host device.

Handling Precautions

- The number of connected units refers to the number of units that can be connected electrically. In this kind of connection, you must check whether or not the transmission speed is suited to the required level in the application. Consult a Yamatake sales agent.
- Event output module DMC10E is not included in the number of connected units.

■ Setting the Device Address

The device address must be set to the DMC10 in order to use the DMC10.
Set the device address as follows:

- When connecting 15 DMC10s directly to a single host device
Set the rotary switch for device address on the front panel to 1 to F, respectively, and then turn the power ON again.

! Handling Precautions

The same device address cannot be used. Use unique device addresses.

- When connecting 15 DMC10s each to a host device via multiple CMC10Bs
 - (1) Set the rotary switch for device address on the CMC10B to a number within the range 1 to 99.
 - (2) Set the rotary switch for device address on the front panel of the DMC10 to a value within the range 1 to F.

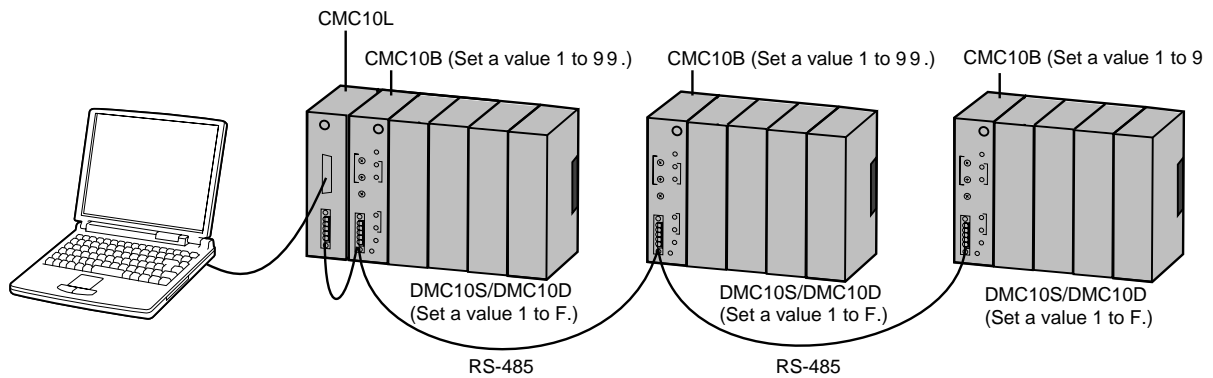

📖 Note

The CMC10B allows up to 31 DMC10s to be connected to a host device.

! Handling Precautions

- The CMC10B cannot be connected if MODBUS is used.
- Be sure to set the device address of DMC10s connected to the same CMC10B to unique values.
- The same device address can be used when a DMC10 is connected to different CMC10Bs.
- For details on CMC10B settings, refer to the Communications Controller CMC10B (CPL/CPL Converter) separate Instruction Manual, Design Manual CP-SP-1064E.

■ Configuration When Combined with the CMC10

● Connecting two CMC10s

Change the setting of the communications disconnection switch on the base to the right when two CMC10Bs are linked by the side connector. Slave communications between CMC10s are independent of this setting.

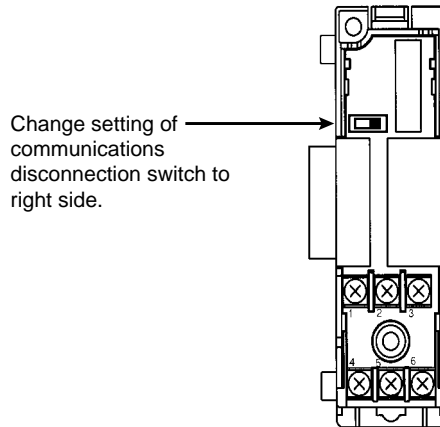

(Example) In the following instrumentation configuration, the communications disconnection switch on the base of only the CMC10Bs indicated in the figure must be set to the right to isolate slave communications with the CMC10B on the left side: This saves wiring to the power supply.

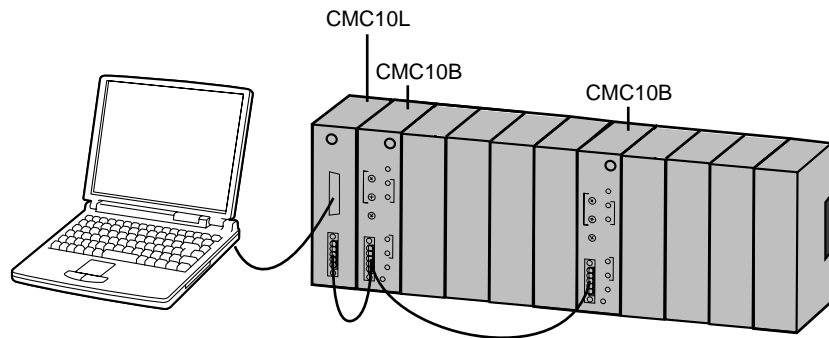

● Position of CMC10B

The CMC10B can be positioned anywhere within a linked group.

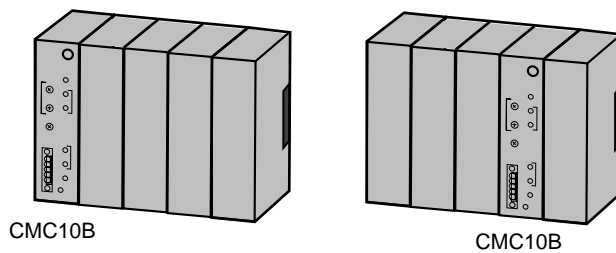

■ Layout of Event Output Module DMC10E

Only one event output module DMC10E can be used within a group linked by connectors.

When the connection is made by wiring from the bases without using the side connectors as shown below, each group is independent and a new event output module can be used.

● Position of event output module

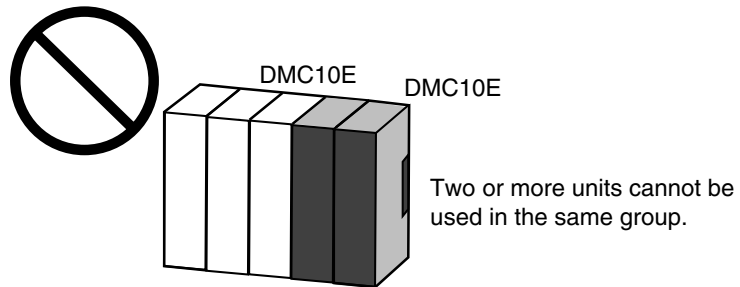
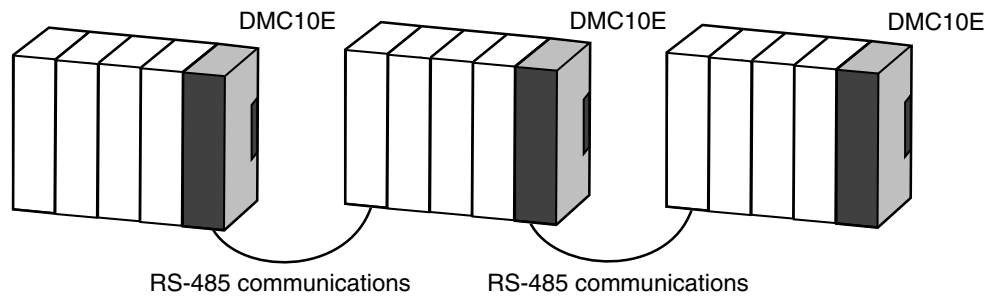

The event output module DMC10E can be positioned anywhere within a linked group.

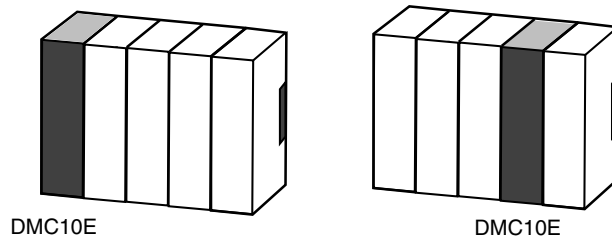

Chapter 6. SETUP & OPERATIONS

■ Overall Operation Procedure

The following operation and preparations are required to use the DMC10:

- Step1** Determine the values of the DMC10's parameters for running from the user's application.
- Step2** Enter the setup parameters for running to the communications device.
(computer, sequencer, PLC, etc.)
- Step3** Write the setup parameters to the DMC10 from the communications device.
(The DMC10 must be mounted on the panel and wired beforehand.)
- Step4** Start running and tune the control constants.
(This step is sometimes not required when self-tuning is used.)

Note

The exclusive Smart Loader Package SLP-D10 is available for the DMC10. This loader allows you to easily set up data before you start running the DMC10, enter setup parameters for running, monitor operation while the DMC10 is running and changing the settings.

When the exclusive Smart Loader Package is not used, the user must make the program for the DMC10.

The Smart Loader Package drastically reduces the load in creating and debugging programs, reduces trouble in setup and monitoring, and reduce the size of the program on the host communications device.

■ Setup Method

There are three ways of setting up the DMC10:

1. When the exclusive Smart Loader Package is used to set up the DMC10 or monitor the DMC10 while it is running:
Proceed to **“Chapter 7. LOADER.”**
2. When a user program is used to set up the DMC10 or monitor the DMC10 while it is running:
Proceed to **“Chapter 10. COMMUNICATIONS FUNCTIONS.”**
3. When the exclusive Smart Loader Package is used to set the required setup parameters before running the DMC10, and the user program is used to set parameters such as SP (set point) or PV (process variable) that required monitoring or changing while the DMC10 is running:
Read both **“Chapter 7. LOADER”** and **“Chapter 10. COMMUNICATIONS FUNCTIONS.”**

Chapter 7. LOADER

7 - 1 Introduction

■ Loader Functions

The SLP-D10 has three functions:

- Setup function
- Monitor function
- Adjustment function

● Setup function

This function is for setting up parameters required for running the DMC10 on the personal computer and writing (setting) them to the DMC10. Up to about 70 types of parameters can be set.

● Monitor function

After the setup parameters have been written to the DMC10, changes to and tuning of control constants while the DMC10 is running, switching of modes (RUN/READY, AUTO/MANUAL, etc.), run state and alarm occurrence can be checked.

The run state can also be checked on the Trend screen, and sampled data can be output in CSV format so that it can be handled in third-party spreadsheet software such as Microsoft Excel.

❗ Handling Precautions

The monitor target is limited to only one unit when the loader jack on the front panel is used for performing monitoring.

● Adjustment function

This function is used when the user adjusting DMC10 input.

For details on the adjustment function, see [“Chapter 12. ADJUSTMENT & ZENER BARRIER ADJUSTMENT.”](#)

❗ Handling Precautions

When the adjustment function is used, adjustment value stored on the DMC10 so far are discarded. (When this function is used for the first time, the DMC10's default adjustment values are discarded.) Pay sufficient attention to this when using this function.

■ System Operating Environment

The following system environment is required for using the SLP-D10:

● Hardware

Item	Description	
Personal Computer	Target model	PC/AT compatible with a Pentium chip or higher
	Memory	32M byte or more
	Operating system	Windows98/Me/2000 Professional/XP Home edition/XP Professional
	USB port	1 port or more
Application	Spreadsheet software	Excel, etc. (when using CSV files)
	Web browser	Internet Explorer, etc. (when using HTML files)
Peripheral Devices	Display	Windows compatible display connectable to or built-into computer body
	Hard disk drive	Hard disk with at least 40M byte of free space
	CD-ROM drive	1 drive or more
	Pointing device	Windows compatible mouse or equivalent device

! Handling Precautions

- Before starting up SLP-D10, quit all other applications.
If you start up SLP-D10 while another application is running, SLP-D10 may not function.
Also, set the power save setting, infra-red communications and screen saver to OFF.
- Make sure that the [Decimal symbol] has been set to "." for [Control Panel]–[Regional Settings]–[Number]. If it has been set to other character, the loader cannot correctly function.

● Hardware configuration

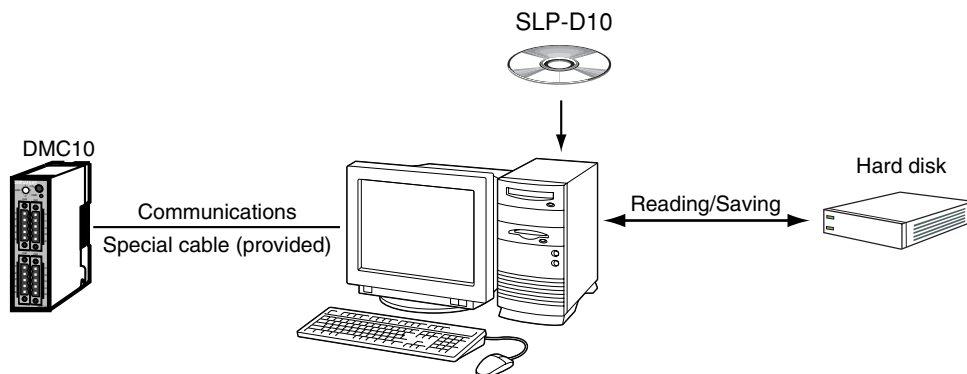

! Note

Personal computer used for confirmation of operating environment.

Manufacturer	Model No.
Dell	Optiplex Gxi5200
Dell	Optiplex GX5166
Fujitsu	FMV-5166T3

7 - 2 Installing, Starting up and Quitting the Software Package

■ Installation

This section describes how to install the SLP-D10 on a personal computer.

! Handling Precautions

If you start up the Installer while another application is running, the Installer may malfunction.

Remove other resident applications from their directories before starting up the Installer.

The SLP-D10 sometimes cannot be started up depending on the combination of other applications and drivers.

For details on Windows and personal computer settings, refer to the User's Manuals provided with Windows and the personal computer.

● Installing SLP-D10

(1) Put the CD in the CD-ROM drive of your personal computer.

>> The installation program starts automatically and the following screen appears:

(2) Only when the SLP-D10 of old version has been installed, click [OK] to delete the old SLP-D10.



► The following screen appears:

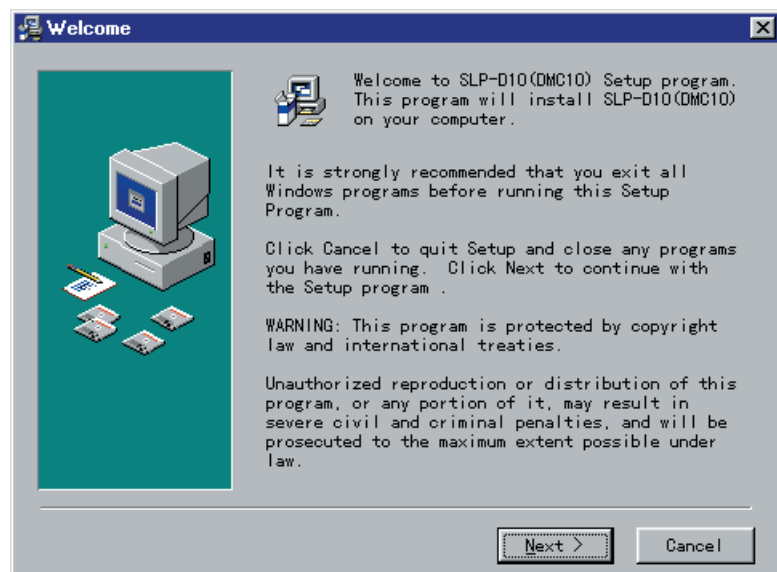

(3) Click [Next>].

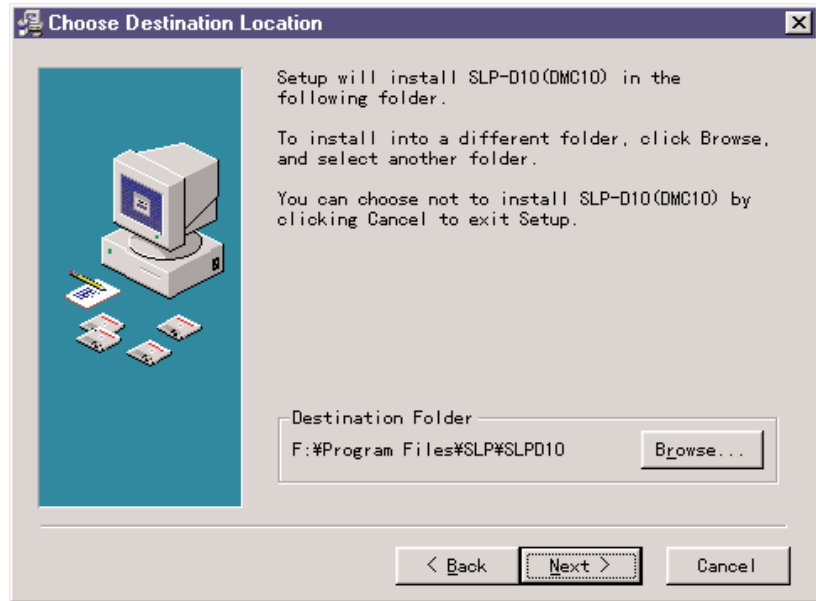

Note

To change the installation destination directory, click [Browse...].

(4) Click [Next>].

► The following screen appears.

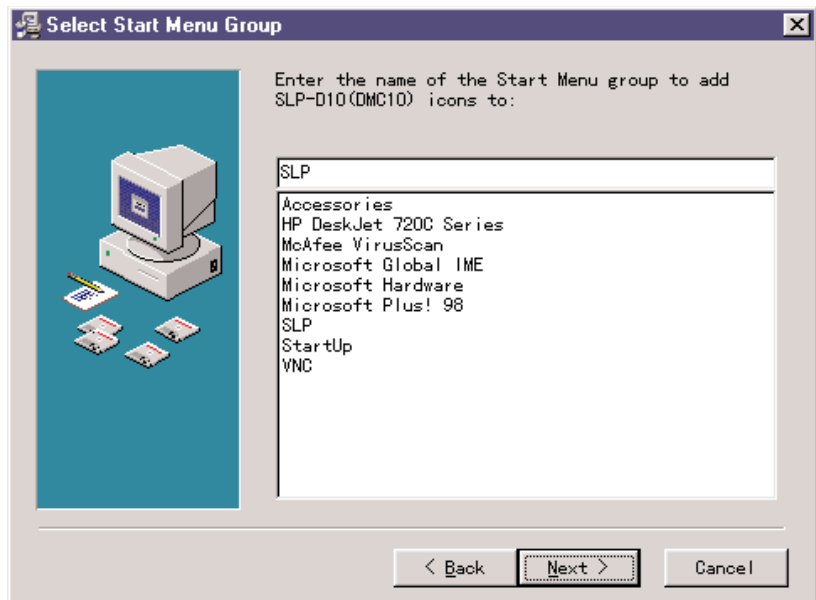

(5) Click [Next>].

Note

To change the group, enter the new group name.

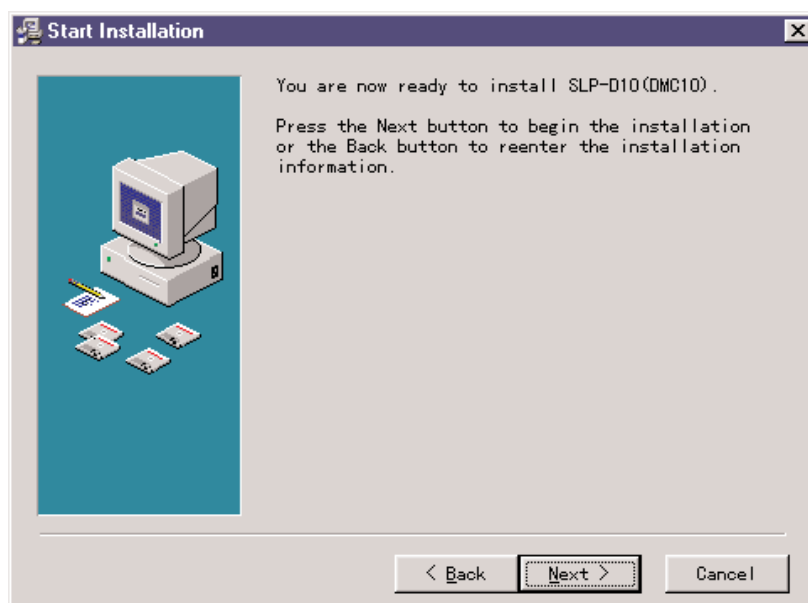

(6) Click [Next>].

(7) Click [Finish].

► When installation ends normally, the following screen appears:

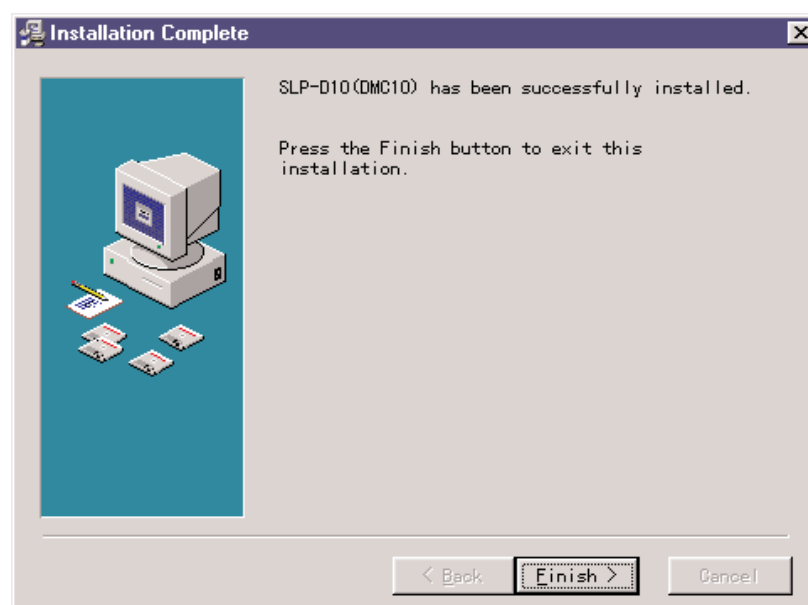

■ Device Driver Installation for USB Loader Cable

A device driver must be installed before using the USB loader cable.
Follow the procedure below to install the device driver.

● Installing the device driver

! Handling Precautions

- Be sure to follow the procedure below when installing the device driver. The USB cable may not be recognized if the procedure is not followed. If the cable is not recognized, uninstall the driver and then install it again.
- Administrator privileges on the computer are required for driver installation. Installation should be done by the administrator or by a user who belongs to the administrator group. The USB loader cable is supported on Windows 98/Me/2000/XP (32 bit type). It is not supported on 64-bit Windows XP, or on Windows 95, Windows NT, MS-DOS or PC-DOS.
- If there are multiple USB ports, connect the USB loader cable to the same port every time. If it is connected to a different port, there is a chance that driver installation may be required again.

1. Put the SLP CD-ROM into the CD-ROM drive of the personal computer.

When the installation program starts, cancel it.

2. Insert the USB loader cable into the USB port.

>>When Windows recognizes the USB cable, the notification shown below appears on the task tray and the driver installation wizard appears.



3. Install the device driver.

(1) Usually, when Windows recognizes the USB loader cable, the window shown below appears. (In some cases, depending on the Windows environment, it may not appear.) Select [No, not this time] and click [Next >].

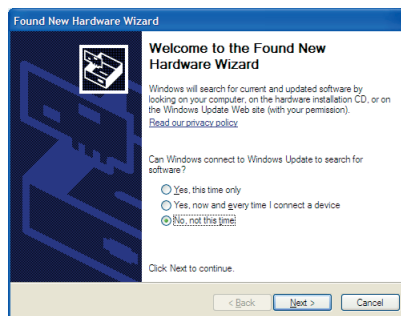

- (2) For the retrieval location of the device driver to be installed, select [Install from a list or specific location (Advanced)] and click [Next >].

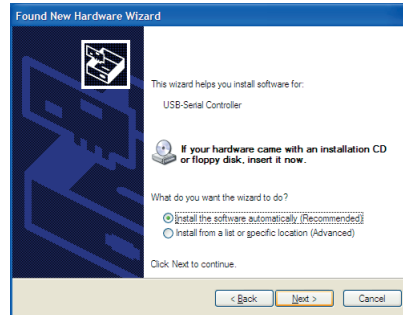

>>Retrieval of the device driver starts.

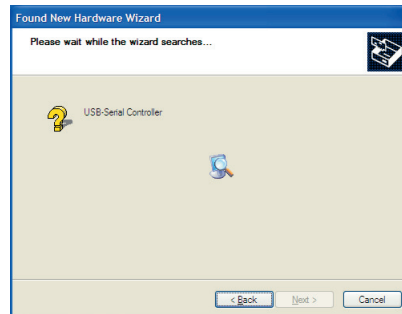

>>When the device driver is found, the following window appears:

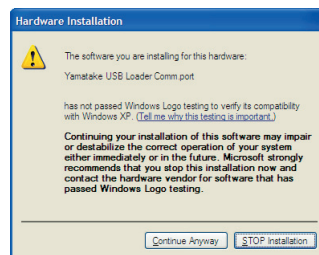

- (3) Click [Continue Anyway].

>>Installation of device driver starts.

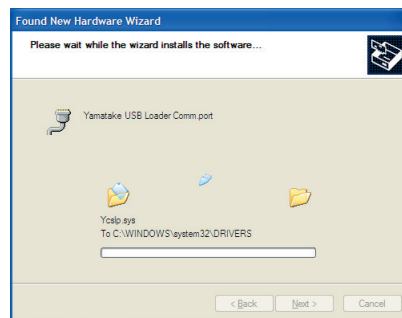

>>When the device driver installation is complete, the following window appears:

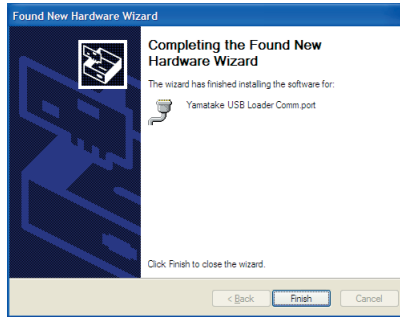

(4) Click [Finish].

>>When the installation is complete, the notification shown below appears on the task tray, and Windows now correctly recognizes the USB loader cable.

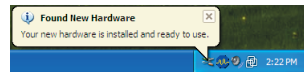

(5) Get the number of the Yamatake USB Loader Comm. port from [Ports (COM & LPT)]. [Ports (COM & LPT)] may be found by navigating to [Control Panel] → [System] → [Hardware] → [Device Manager] (for Windows XP/2000), or [Control Panel] → [System] → [Device Manager] (for Windows 98/Me).

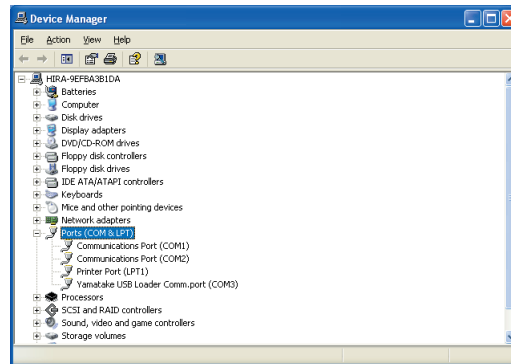

(6) Start the Smart Loader Program, select [Menu] → [Option(E)], and set to the communications port number obtained in the previous step. Then press the [OK] to complete the configuration.

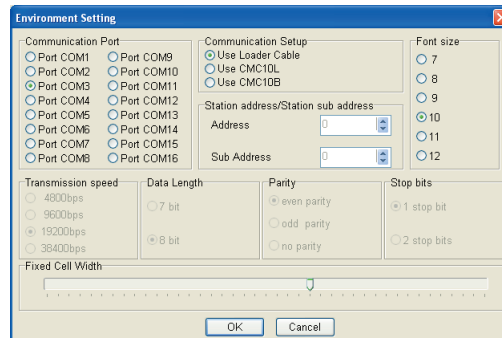

Note

If the CD-ROM for the SLP is not available for the retrieval of the device driver to be installed in step (2) above, select [Install from a list or specific location (Advanced)] and click [Next >].

Then, click [Browse] to specify the folder in which SLP is installed, and click [Next >]. Standard folder locations are:

- For SLP-C35J50, normally [C:\Program Files\slp\SLPC35].
- For SLP-C35PRO, normally [C:\Program Files\slp\SLPC35PRO].
- For SLP-D10, normally [C:\Program Files\slp\SLPD10].

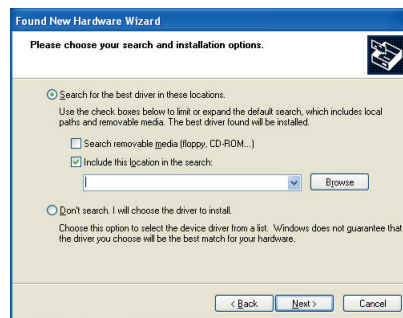

Proceed with steps (3) to (6).

● Uninstalling the device driver

! Handling Precautions

- Removing the driver requires restarting the computer. Close other applications first, and then uninstall the driver.
- To uninstall the driver, administrator rights are required on the computer. Uninstalling should be done by the administrator or by a user who belongs to the administrator group.

1. Execute the driver removal program.

(1) Start the removal program, DrvRemover_Ycslip.exe, by double-clicking the  icon on the CD-ROM. If the SLP CD-ROM is not available, there is also a copy of DrvRemover_Ycslip.exe in the folder in which SLP is installed:

- Normally [C:\Program Files\slp\SLPD10].

>>A confirmation dialog box for the driver removal appears.

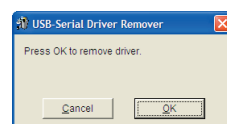

(2) Click [OK].

>>The following window appears:

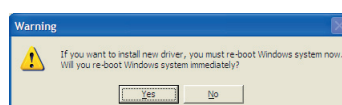

(3) To complete the removal of the driver, the computer must be restarted.

Click [Yes] to restart the computer.

■ Starting Up SLP-D10

(1) Click [Start] at the bottom of the screen, and click the [SLP-D10 (DMC10)] under [Programs]-[SLP].

▶ The SLP-D10 is started up, and the menu window is displayed.



Note

For details on the operating system and the mouse you are using, refer to the User's Manual provided with Windows.

■ Quitting SLP-D10

(1) Click [close] at the top right of the screen.

The operation is the same by selecting the [Menu]-[Quit] command.

(2) Click [OK].

● Quit dialog box

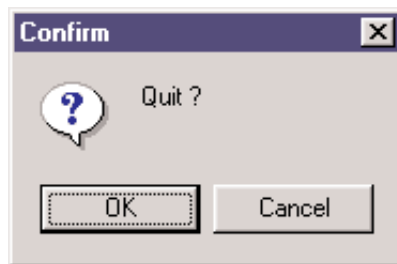

7 - 3 Setup Function

■ Outline of Setup Function

The setup function allows you to set the various parameters (about 10 to 70 constants required for operation) and write these parameters to the DMC10 so that it functions according to your particular control requirements. When the DMC10 is used for the first time, it will not function as required unless it is set up by using this setup function.



Parameters such as SP (set point) and control constants (PID values) that are changed relatively frequently while the DMC10 is running can also be set from the monitor function screen.

By the setup function, parameters that hardly need changing later once they are set are saved to file in list format before the DMC10 is run, and the saved file is called up and written to the DMC10 in a single operation.

■ Screen Explanations

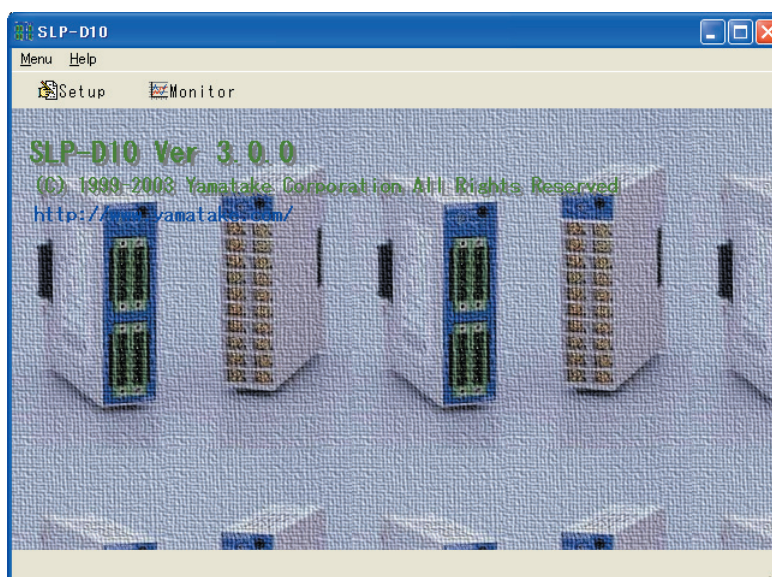
● Menu screen



Menu	Icon	Sub Menu	Description	Shortcut Keys
Menu		Setup	Displays the Setup window.	Ctrl+S
		Monitor	Displays the Monitor/Trend window.	Ctrl+M
		Adjust	Displays the Adjustment window.	Ctrl+J
		Option (E)	Changes the environment setup.	Ctrl+E
		Quit	Quits the application.	Ctrl+Q
Help		Version (A)	Displays the version information.	Ctrl+A

● Setup screen

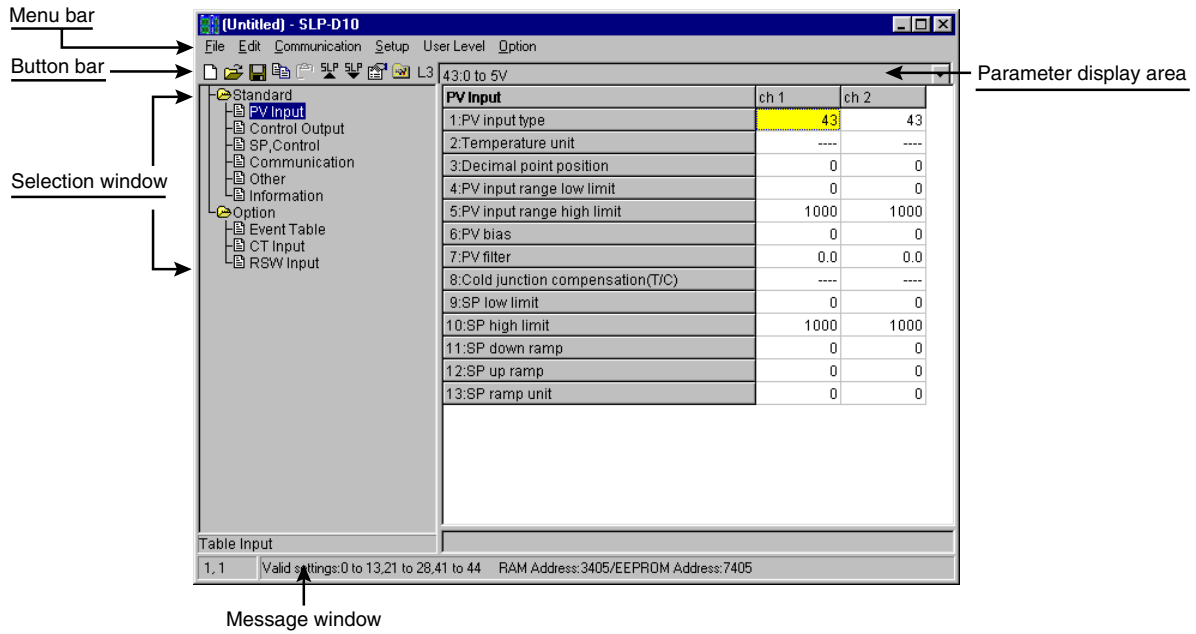

Menu	Icon	Sub Menu	Description	Shortcut Keys
File		New	Creates new data.	Ctrl+N
		Open	Opens existing data.	Ctrl+O
		Save	Saves the active data.	Ctrl+S
		Save As	Saves the active data with a new name.	Ctrl+A
		CSV Out (X)	Saves the active data in CSV format.	Ctrl+X
		HTML Out (H)	Saves the active data in HTML format.	Ctrl+H
		Quit	Quits the application.	Ctrl+Q
Edit		Data Check	Checks all setting values.	Ctrl+D
		Bit Edit	Inputs to bit lists.	Ctrl+B
		Copy	Stores the copy source.*	Ctrl+C
		Paste	Pastes the stored copy data.*	Ctrl+V
Communication		Read(DMC10→SLP)	Reads the device data.	Ctrl+R
		Write(SLP→DMC10)	Writes the data to the device.	Ctrl+W
Setup		Standard(A)		
		Option(B)		
User Level		Basic(L1)		
		Standard(L2)		
		High function(L3)		
Option		Type Setting	Changes the type setting.	Ctrl+T
		Environment Setting	Changes the environment setup.	Ctrl+E
		Special function (U)		
		Zener barrier adjust (Z)		
		Automatic motor adjustment (M)		

* Data of the row at the current cursor position is copied and pasted one row at a time.

■ Operation Procedure

● Off-line tasks

“Off-line tasks” are tasks performed without connecting cables to the DMC10.

The following tasks are performed:

Step 1: Setting up the loader type

Step 2: Initialization (clearing previous setting values)

Step 3: Setting up the environment

Step 4: Setting special functions

Step 5: Setting up DMC10 parameters

Step 6: Saving setup data

Step 7: Downloading the setup

! Handling Precautions

Operations in steps 1 to 6 are required before the setup parameters are entered on the DMC10. Be sure to perform these steps. Otherwise, the DMC10 may be set up incorrectly. For example, the required setup items may not be displayed or unrequired items may be displayed.

● Step 1 (setting up the loader type)

Set up the SLP-D10's type to match the DMC-10's model number.

(1) Click .

The operation is the same by selecting the [Option]-[Type Setting] command or the [Ctrl] + [T] keys.

▶ The Type Setting dialog box is displayed.

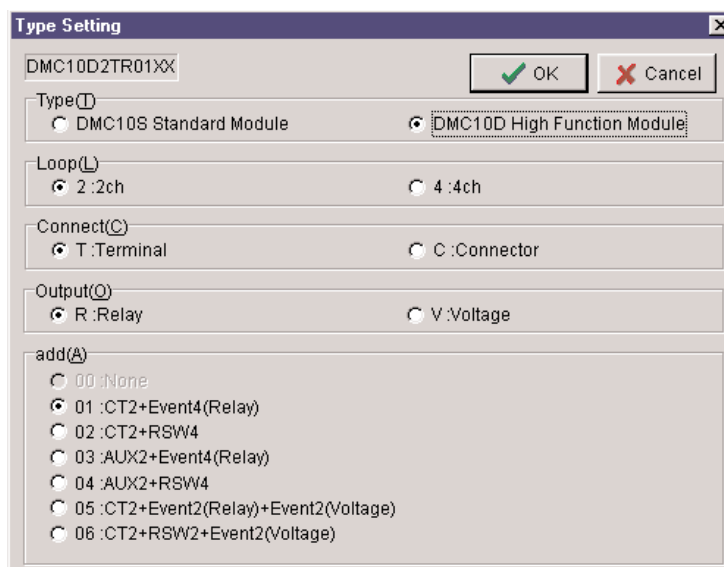

(2) Set the functions, number of control loops, wiring method, control output and additional functions.

(3) Select from the selection items for each setting item.

(4) Click [OK].

📖 Note

The type setting can also be set by uploading the data from the DMC10 to be used. This prevents downloading wrong parameter data by setting an incorrect model number.

[!] Handling Precautions

- “Type” set here is the setting for internal use on the SLP-D10. The model number of the DMC10 will not change even if the type is changed on the SLP-D10.
- If you select [4ch] when designating the [Loop], “Connect” is forcibly fixed to “Connector” and “add” to “None”.
- For an explanation of each of the specifications, see the Model Selection Guide.

● Step 2 (initialization)

(1) Click [New].

The operation is the same by selecting the [File]-[New] command or the [Ctrl] + [N] keys.

▶ The New dialog box appears.

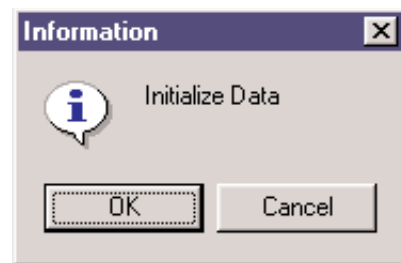

(2) Click [OK].

▶ A new file opens.

● Step 3 (setting up the environment)

Set the communications port and font on the personal computer.

(1) Click .

The operation is the same by selecting the [Option]-[Environment Setting] command or the [Ctrl] + [E] keys.

▶ The Environment Setting dialog box appears.

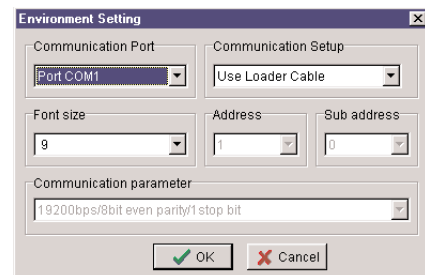

(2) Set the communications port. Select the port from the selection items.

(3) Set the font size. Select the front size from the selection items.

(4) Click [OK].

[!] Handling Precautions

- Normally, use “COM1”.
Even if another communications port can be selected, it sometimes cannot be used depending on its shape.
- Normally, use “Use Loader Cable.”

- Step 4 (setting special functions)

Set this item to use special functions. To display the setting items relating to the special functions, click the check box in front of the function name to be used.

[Multi-SP set] Set this item when using multiple SP sets. The DMC10 holds up to 16 SP values.

[Event output special operation]

Set this item to use event output assignments. See page 8-3.

[External switch input special operation]

Set this item to use external switch assignments. See page 8-4.

[Heat/cool control] DMC10D only Use heat/cool control. See page 9-2.

[Remote SP input] DMC10D only User remote SP input. See page 9-2.

[MV branch output] DMC10D only Use MV branch output.

[Position proportional control type]

DMC10D only Use position proportional control type.

[Energy saving] DMC10D only Use energy saving function.

- Step 5 (Setting up DMC10 parameters)

Move the cursor to the target channel of each setup item, and perform the following operations:

- When the setting is a numerical value:
Enter the numerical value, and press the Return key.
- When a setting is selected by a number:
To display the list of settings, click the setting display on the parameter display area. Select and click the desired item name to end the setting.

Set each of the parameters required for running the DMC10. The following two types of parameters are set:

- Basic functions: Basic functions for device operation such as control and communications functions
- Option functions: Functions relating to option specification such as event output, external switch input, and current transformer input

Handling Precautions

- In addition to the above functions, the DMC10 has several other functions called “special functions.” These functions are setting groups or setting items within basic functions or option functions. For details on the functions, see “[Chapter 8. SETUP PARAMETERS \(Common to DMC10S and DMC10D\)](#)” and “[Chapter 9. SETUP PARAMETERS \(DMC10D\)](#).”
- “— — —” is displayed within the cell for parameters whose setting is not required or is prohibited by other setting items. These parameters cannot be set. In this case, re-check the type setting or other related settings.
- Items on the horizontal axis are channel numbers when basic functions are being set up, and are event output numbers or external switch input numbers when option functions are being set up.
- About connection to the personal computer
Normally, the special cable is used for connecting the personal computer to the DMC10. However, the CMC10B/L is used to enable the connection to the DMC10 when the communications setup is to be changed by the [Option]-[Environment Setting]-[Communication Setup] command. Before the CMC10B/L is connected, the communications setup of the loader must be matched to that of the DMC10. The communications setup cannot be changed when the special cable is used.

- Step 6 (saving setup data)

When you have finished making the settings, save the setup.

Saving setups in advance and using saved setups greatly reduces the time and load when setting up the loader. The following items are saved:

- Type
- Use/non-use of special functions
- Setup parameters

- (1) Click [Save As].

Select the [File] command.

The operation is the same by selecting the [Ctrl] + [A] keys.

▶ The Save As dialog box appears.

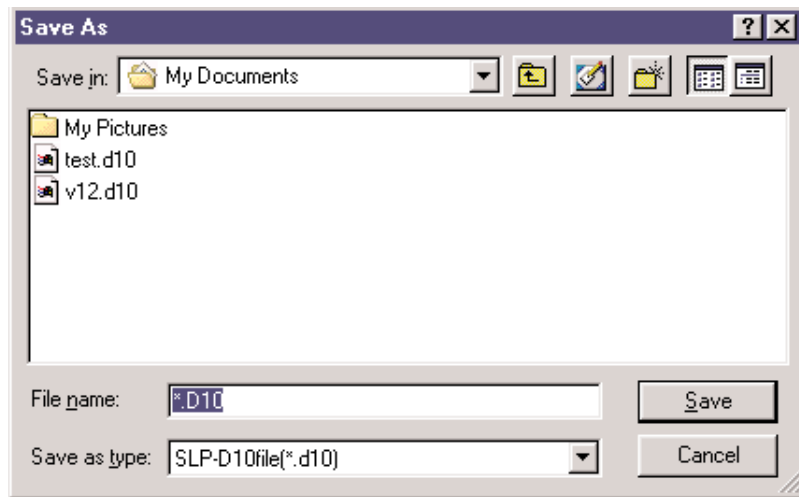

- (2) Enter the file name, and click [Save].

- Step 7 (downloading the setup)

Write the set parameters or parameters called up from a saved file to the DMC10.

- (1) Use the special loader cable to connect the personal computer to the DMC10 body to write the setup parameters to.

- (2) Turn the DMC10 ON.

- (3) Click .

The operation is the same by selecting [Write(SLP→DMC10)] command in the pull-down menu.

The message “Writing is going to be executed.” is displayed.

- (4) Click [OK].

▶ This starts writing of the setup parameters.

During writing, the message “Please wait.” is displayed. When writing ends, the message “Normal end” is displayed.

Handling Precautions

If writing fails, the message “Communications error has occurred.” is displayed.

If writing is not possible, refer to [“Chapter 13. TROUBLESHOOTING.”](#)

7 - 4 Monitor Function

■ Outline

The Smart Loader Package SLP-D10 exclusively for the DMC10 is used for monitoring DMC10 operation.

To enter the monitor screens, click [Monitor] in the menu screen.

The Smart Loader Package has the following two monitor screens:

- **Numeric Monitor screen:** This screen is for performing operations such as changing setups or switching modes.
 - Numeric display of the various running parameters (parameters can be changed)
 - Lamp indication of the various running modes (lamp indications can be operated)
 - Alarm display (representative and detailed)
- **Trend Monitor screen:** This screen is for monitoring the running state of the DMC10 in the form of a trend graph.
 - Screen display of trends for max. of eight data items
 - Export of sampled data as CSV file
 - Trend screen dumps
 - Data type: PV, SP, MV, user-defined data (all analog data that can be communicated)
 - Sampling cycle: Variable within the range 1 to 3600s
 - Max. sampling count: 7200 (fixed regardless of number of data items to sample)



Note

A “CSV file” is the data format that can be handled in third-party spreadsheet software such as Microsoft Excel. In this format, sampled trend data can be interpreted in spreadsheet software.

These screens can be used to perform the following operations:

- Monitoring of the running state and changing of parameters in the Numeric Monitor screen
- Switching of the run mode in the Numeric Monitor screen
- Tuning of control constants in the Numeric Monitor screen
- Monitoring of trends and sampling of data while the DMC10 is running
- Monitoring of alarm states in the Numeric Monitor screen

! Handling Precautions

- **About connection to the personal computer**
The loader must be connected to the DMC10 by the loader cable when the Smart Loader Package SLP-D10 is used to set up the DMC10 or monitor its running.
To access other DMC10s, the loader cable must be swapped.
- The Trend screen must be set up to start the trend monitor. Be sure to set up the Trend screen before starting monitoring.
- The sampling cycle sometimes shifts due to fluctuations in the communications cycle. To perform measurement at exact times, use the special recorder or data logger.

Screen Explanations

Numeric Monitor screen

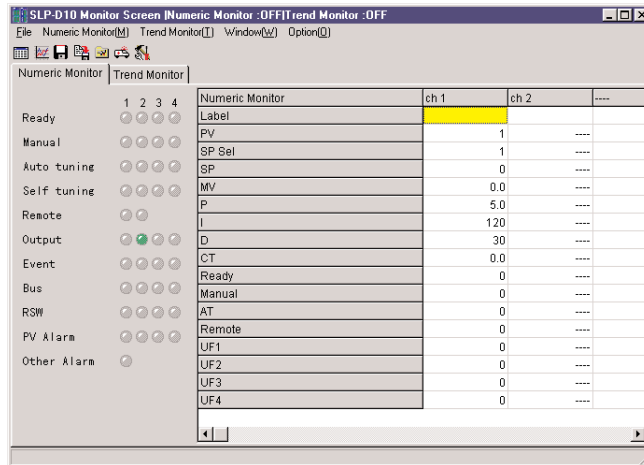

Trend Monitor screen

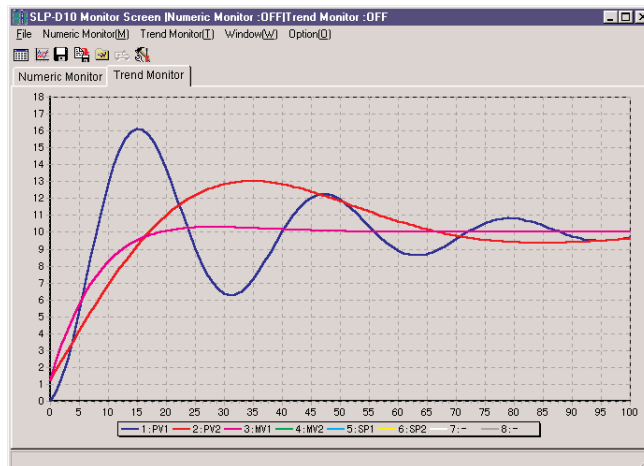

Menu	Icon	Sub Menu	Description	Shortcut Keys
File		New	Initializes the monitor/trend setup.	Ctrl+N
		Quit	Quits the Monitor window.	Ctrl+Q
Numeric Monitor (M)		Numeric Monitor Start/Stop (M)	Starts/stops the monitor.	Ctrl+M
Trend Monitor (T)		Trend Monitor Start/Stop (T)	Starts/stops trend sampling.	Ctrl+T
		CSV Out (X)	Outputs the trend data in CSV format.	Ctrl+X
		Clipboard Graph Out (C)	Outputs an image of the graph to the Clipboard.	Ctrl+C
Window (W)		Numeric Monitor (M)	Displays individual numeric monitors.	
		Numeric Group Monitor (G)	Displays numeric group monitors.	
		Trend Monitor (T)	Displays trend monitors.	
Option (O)		Setup	Displays the Setup window.	
		Alarm (A)	Displays the Alarm Details window.	
		Command Line (C)	Displays the Command Line window.	

■ How to Operate the Numeric Monitor Screen

● Start of monitoring (start of communications)

The following operation is required to start monitoring. Otherwise, monitoring and rewriting of data cannot be performed:

- Click .

The operation is the same by selecting [Numeric Monitor]-[Numeric Monitor Start].

- ▶ During normal operation: The data on the DMC10 is displayed.

During an error: The message “Check the device to which the loader is connected.” is displayed. Remedy according to **“Chapter 13. TROUBLESHOOTING.”**

The following operations are possible when the device and the loader are correctly connected:

● Monitoring of run state and changing of parameters

Numeric monitor (displayed in table format) Numeric group monitor	Label PV SP value SP set Manipulated variable (MV) PID value Heater current value RUN/READY mode AUTO/MANUAL mode Auto-tuning start/stop state
State monitor (displayed in lamp lighting format)	RUN/READY mode AUTO/MANUAL mode Auto-tuning start/stop state Self-tuning start/stop state Control output ON/OFF state Event output ON/OFF state Event bus output ON/OFF state* External switch input ON/OFF state PV alarm occurrence condition Alarm occurrence condition
Operation (Operations possible in numeric changes are limited as follows.)	SP value change SP set change Manipulated variable (MV) change in MANUAL mode PID value change RUN↔READY switching AUTO↔MANUAL switching Auto-tuning start↔stop switching Entry of channel tag name
Lamps (Lamps operable by clicking are limited as follows.)	RUN↔READY switching AUTO↔MANUAL switching Auto-tuning start↔stop switching
About the operation mode	RUN/READY mode 0: RUN 1: READY AUTO/MANUAL mode 0: AUTO 1: MANUAL

* The ON/OFF state of monitor event bus outputs for event bus output ON/OFF states are reflected only on devices where ON (or OFF) operation has been performed on the event bus output. On other devices, the ON/OFF state is indicated on screen as “OFF”.

Note

Channels can be appended a label name for on-screen use only. This name is for screen use only, and is not downloaded to the DMC10.

● **Changing of data, switching of modes**

- Operation by entry of numerical values → Enter the numerical value, and press the Return key.
- Operation by clicking a lamp → Click the target lamp indication.

● **Setting of user-defined address**

Optional data not in the table can be registered to user configuration address UF 1 to 4 in the table. Data can be read or written according to the data type.

How to set user-defined address:

- (1) Select the [Set monitor] tag under [Option (O)]-[Setup] in the pull-down menu.
- (2) Enter the address of the data to display according to [“10-8 List of All Communications Parameters”](#) (page 10-16).

 **Handling Precautions**

Up to four user configuration data items can be set. This data, however, is common to all channels.

● **Use of the command line**

Data can be read or written or the mode switched by directly entering communications commands on the command line.

 **Handling Precautions**

- Transmission of the wrong command may result in trouble on the DMC10. For this reason, take sufficient care when describing command types, addresses, data and other information.
- For details on communications commands and data addresses, see [“Chapter 10. COMMUNICATIONS FUNCTIONS.”](#)
- Memory protection is enabled.

● **Checking details of alarms**

You can check the details of alarms in the Alarm window when an alarm occurs.

- Click .

The operation is the same by selecting the [Option (O)]-[Alarm (A)].

- The details of the alarm that is occurring are displayed.

 **Handling Precautions**

This window displays the details of currently occurring alarms, and does not have a function for restoring the DMC10. To restore the DMC10, you must perform the appropriate remedy described in [“Chapter 13. TROUBLESHOOTING.”](#)

● **About the numeric group monitor**

The numeric group monitor can be used when [Connect via CMC10] is set by the [Environment Setting]-[Communication Setup] command. Connect the loader cable to CMC10B. Up to eight groups can be monitored.

■ How to Operate the Trend Monitor

● Setup

Select [Trend Setup] at [Option (O)]-[Setup], and make the following settings for each sampled data (1 to 8).

As the cycle and display upper/lower limits are common to all channels, these items can be set for sampled data 1 and not for sampled data 2 to 8.

Setting Item	Description	Setting Range	Factory Setting
Cycle	Setting of sampling cycle	1 to 3600s	1
Display lower limit	Lower value of vertical axis of screen display	-2000 to display upper limit	0
Display upper limit	Upper value of vertical axis of screen display	Display lower limit to 10000	0
Display	Designation of display/non-display on screen	0: Display OFF 1: Display ON	1
Data type	Type of sampled data	0: Not used 1: PV of channel 1 2: PV of channel 2 3: PV of channel 3 4: PV of channel 4 5: MV of channel 1 6: MV of channel 2 7: MV of channel 3 8: MV of channel 4 9: SP of channel 1 10: SP of channel 2 11: SP of channel 3 12: SP of channel 4 13: User-defined data	
User-defined address	Address of relevant parameter when the data type is set as "user type"	Address of communicable parameter	
Communications address	Set the communications address when a CMC10B, for example, is used.	0 to 127	
Communications sub-address	Set the communications sub-address when a CMC10B, for example, is used.	0 to 127	

! Handling Precautions

When a user-defined address has been specified, numerical values are displayed without a decimal point. Manually set the decimal point position in the Numeric Monitor Setup screen.

● Starting sampling

When you have finished making the settings, monitoring of trends can be started. Click .

The operation is the same by selecting the [Trend Monitor]-[Trend Monitor Start]. This starts trend sampling, and the trend of the specified parameter is displayed on screen.

- When trend monitoring is started, operation is continued until either operation is stopped or until data has been sampled for 7200 times.
- Trend monitoring automatically stops when data has been sampled for 7200 times even if operation is not stopped.
- During trend monitoring, the Numeric Monitor screen can be entered, but the loader cannot be quit nor the Setup screen entered. To quit the loader or enter the Setup screen, quit trend monitoring.

● **Stopping sampling**

Select [Trend Monitor]-[Trend Monitor Stop].
This stops monitoring of the trend.

● **Saving sampled data**

Data sampled by trend monitoring can be saved to file in CSV format. Data sampled in this format can be handled in third-party spreadsheet software such as Microsoft Excel.

 **Handling Precautions**

- Data can also be saved to file while trend monitoring is in operation.
- Data saved to file remains on screen or on the personal computer as long as the loader is not initialized. The data, however, cannot be re-displayed on screen.

● **Clipboard graph output**

The display details on the Trend Monitor screen can be saved to Clipboard as a screen dump.

Chapter 8. SETUP PARAMETERS (Common to DMC10S and DMC10D)

8 - 1 List of Setup Parameters

Basic Functions

For details, see “8-2 Explanation of Basic Functions” (page 8-5).

E: Easy S: Standard M: Multi-function

Category	Item Name	Setting Range	Factory Setting	User Level	Remarks
PV input	Input type	According to PV input type range table	43: 0 to 5V	E/S/M	See page 14-3.
	Temperature unit	0: °C 1: Special unit	0: °C	M	At thermocouple or RTD input
	Decimal point position	0: With no decimal point 1: 1 decimal digit is indicated 2: 2 decimal digits are indicated 3: 3 decimal digits are indicated	0: With no decimal point	S/M	Settable at DC voltage or DC current input. Or, some thermocouple or RTD ranges settable
	PV range lower limit	-2000 to +10000	0	E/S/M	Settable at DC voltage or DC current input
	PV range upper limit	-2000 to +10000	1000	E/S/M	Settable at DC voltage or DC current input
	PV bias	-2000 to +10000	0	S/M	-
	PV filter	0.0 to 120.0s	0.0s	M	-
	Cold junction compensation action	0: Internal 1: External	0: Internal	M	At thermocouple input only
	Lower SP limit	PV range lower value to upper SP limit value	PV range lower limit	S/M	-
	Upper SP limit	Upper SP limit value to PV range upper value	PV range upper limit	S/M	-
	SP down gradient	0 to 10000	0	M	-
	SP up gradient	0 to 10000	0	M	-
	SP up gradient time unit	0: unit/min 1: unit/h	0	M	-
Control output	Control method	0: ON/OFF control 1: Control by self-tuning 2: Control by PID fixed values	0: ON/OFF control	E/S/M	-
	Control action	0: Heat control (reverse action) 1: Cooling control (direct action)	0: Heat control	E/S/M	-
	Time proportional cycle	5 to 120s (relay output) 1 to 120s (voltage output)	10s	E/S/M	Not settable at ON/OFF control
	Time proportional operating mode	0: Priority on controllability 1: Priority on control device life*	0: Priority on controllability	M	* ON/OFF action once within time proportional cycle. Not settable at ON/OFF control
	PID initial MV	-10.0 to +110.0%	0.0%	M	Not settable at ON/OFF control
	AUTO/MANUAL switching action	0: Bumpless 1: Preset	0: Bumpless	S/M	MANUAL mode cannot be switched to at ON/OFF control.
	Preset manual value	-10.0 to +110.0%	0.0%	S/M	Not settable at ON/OFF control
	MV in READY mode	-10.0 to +110.0%	0.0%	M	-
	MV at PV alarm occurrence	-10.0 to +110.0%	0.0%	M	-
	MV rate-of-change limit	0.1 to 100.0%	100.0%	M	Not settable at ON/OFF control
	Self-tuning up/down startup condition	0: Start at both rise and fall of PV value 1: Start at rise of PV value	0: Start at both rise and fall of PV value	M	Only at control by self-tuning
	Self-tuning correction width	0.0 to 5.0°C (at temperature sensor input) 0.0 to 3.0%FS (at linear input)	2.0°C 0.5%FS	M	Only at control by self-tuning

Chapter 8. SETUP PARAMETERS (Common to DMC10S and DMC10D)

Category	Item Name	Setting Range	Factory Setting	User Level	Remarks
SP, control parameters	SP value	Lower SP limit value to upper SP limit value	0	E/S/M	-
	Proportional band (P)	0.1 to 999.9%	5.0%	E/S/M	Settable during control by PID fixed values
	Reset time (I)	0 to 3600s	120s	E/S/M	Settable during control by PID fixed values
	Rate time (D)	0 to 1200s	30s	E/S/M	Settable during control by PID fixed values
	MV lower value (OL)	-10% to MV upper value	0%	M	Not settable during ON/OFF control
	MV upper value (OH)	MV lower value to 110%	100%	M	Not settable during ON/OFF control
	Manual reset value (rE)	-10 to +110%	50%	S/M	Settable during control by PID fixed values and when reset time = 0s
	Differential	1 to 9999unit	5unit	S/M	Settable during ON/OFF control
	Disturbance response coefficient (Quick-FITTER)	0 to 30	0	M	Not settable during ON/OFF control
Communications	Transmission speed	0: 2400bps 1: 4800bps 2: 9600bps 3: 19200bps	3: 19200bps	E/S/M	-
	Data format	0: 8bits, even parity, 1 stop bit 1: 8bits, no parity, 2 stop bits	0: 8bits, even parity, 1 stop bit	E/S/M	-
	Min. communications response time	0: 1ms 1: 10ms 2: 100ms 3: 200ms	1: 10ms	M	Min. time from end of command reception up to start of return of response
	Addition to the min. communications response time	0 to 100ms	0	M	Added to the min. communications response time.
	CPL/MODBUS switching	0: CPL 1: MODBUS (ASCII format) 2: MODBUS (RTU format)	0	M	-
Others	Memory protection	0: All writable 1: Only SP, EV, MODE and communications DI writable 2: Only SP, MODE and communications DI writable 3: Not writable except memory protection	0: All writable	E/S/M	Can be changed on loader.
	LED operation type	0: Lit at all times 1: Blinking in READY mode 2: Blinking in MANUAL mode 3: Blinking in RSP mode 4: Blinking at self-tuning correction standby 5: Blinking at execution of auto-tuning 6: Blinking at PV alarm occurrence 7: Blinking at memory alarm occurrence 8: SP set selection number blinking 9: Blinking during master communications 10: Blinking during master/loader communications 11: Control output mode (lit when ON) 12: Event output mode (lit when ON) 13: Event bus output switch mode (lit when ON) 14: External switch input mode (lit when ON) 15: External bus mode (lit when ON) 16: Communications DI input mode (lit when ON) 17: Blinking during inter-channel deviation control 18: Blinking during SP gradient time 19: Blinking during inference of motor control position	0: Lit at all times	M	-
	Channel targeted for LED operation	0: OR operation on all channels 1: channel 1 2: channel 2 3: channel 3 4: channel 4	0: OR operation on all channels	M	LED action type settings: Not settable in the case of 7, 9 and 10

■ Option Functions

The following option functions are available:

For details, refer to **“8-3 Detailed Explanation of Option Functions”** (page 8-16) onwards. Items that are displayed vary according to model number of the DMC10 and the use setting of special functions.

- Event output
- Current transformer input
- External switch input

Category	Item Name	Setting Range	Factory Setting	User Level	Remarks
Event output (when event output special action is not used)	Type of action	0: No event 1: PV upper limit 2: PV lower limit 3: PV upper/lower limit 4: Deviation upper limit (current reference SP) 5: Deviation lower limit (current reference SP) 6: Deviation upper/lower limit (current reference SP) 7: Inter-channel deviation upper limit 8: Inter-channel deviation lower limit 9: Inter-channel deviation upper/lower limit 10: READY mode 11: MANUAL mode 12: Control action (direct) 13: Auto-tuning startup mode 14: Self-tuning correction standby mode 15: Loop diagnosis 16: Timer 17: Heater line break/overcurrent 18: Heater short-circuit 19: Individual channel, PV, alarm 20: Memory alarm 21: LOCAL 22: SP upper limit 23: SP lower limit 24: SP upper/lower limit 25: Deviation upper limit (final reference SP) 26: Deviation lower limit (final reference SP) 27: Deviation upper/lower limit (final reference SP) 28: SP gradient in progress 29: Inference of motor control position in progress 30: Loop diagnosis 2	0: No event	E/S/M	-
	Target channel	1 or 2 (in case of 2-channel models) 1 to 4 (in case of 4-channel models)	EV/BUS 1→1 EV/BUS 2→2 EV/BUS 3→3 EV/BUS 4→4	E/S/M	Not settable when action type is set to 0
	Alarm OR action	0: None 1: OR action used	0: None	M	-
	Event setting value (main)	According to action type	0	E/S/M	See “Appendix, Advice on Events.”
	Event setting value (sub)	According to action type	1000	E/S/M	See “Appendix, Advice on Events.”
	Hysteresis	According to action type	5	S/M	See “Appendix, Advice on Events.”
	Direct/reverse action	0: Direct action 1: Reverse action	0: Direct	E/S/M	-
	Standby	0: None 1: Standby 2: Standby + standby at SP change	0: None	S/M	Standby action restarted at SP change
	Latch	0: None 1: Latch operation	0: None	M	-
	Action in READY mode	0: Action continued in READY mode 1: Action forcibly turned OFF in READY mode	0: Action continued in READY mode	M	-

Chapter 8. SETUP PARAMETERS (Common to DMC10S and DMC10D)

Category	Item Name	Setting Range	Factory Setting	User Level	Remarks
Event output (when event output special action is not used)	ON delay time (h)	0 to 99h	0	M	-
	ON delay time (min)	0 to 59min	0	M	-
	ON delay time (s)	0 to 59s	0	M	-
	OFF delay time (h)	0 to 99h	0	M	-
	OFF delay time (min)	0 to 59min	0	M	-
	OFF delay time (s)	0 to 59s	0	M	-
Current transformer input	Designated channel for current transformer input	0: OUT1 1: OUT2 3: EV1 4: EV2 5: EV3 6: EV4	CT1→1 CT2→2	M	-
	Measurement standby time	3 to 30 (x 10ms)	3	E/S/M	Standby time = setting value x 10ms
External switch input	Type of action	0: No function 1: "1" added to SP set number 2: "2" added to SP set number 3: "4" added to SP set number 4: RUN/READY 5: AUTO/MANUAL 6: LOCAL/REMOTE 7: Auto-tuning stop/start 8: Self-tuning stop/execution 9: Timer stop/start 10: Latch state release 11: Inter-channel deviation control switching 12: Inter-channel deviation control type 13: External switch input state 14: SP lamp stop	0: No function	E/S/M	Even on models w/out the external switch input option, use with internal bus is possible.
	Target channel	0: All channels 1: Channel 1 2: Channel 2 3: Channel 3 4: Channel 4		E/S/M	Action types: 1 to 5, 7, 8 Channels 3 and 4 are possible on 4-channel models.
	Direct/reverse action	0: Direct 1: Reverse	0: Direct	S/M	-
Auxiliary input	Type of action	0: PV/RSP value 1: PV1-PV2 value 2: SP value 3: Manipulated variable 4: Heat side manipulated variable 5: Cooling side manipulated variable 6: Manipulated variable (PID calculation results before ratio operation) 7: Feedback value	0	E/S/M	-
	Target channel	1: Channel 1 2: Channel 2	AUX→1 AUX→2	S/M	-
	Output type	0: 4 to 20mA 1: 1 to 20mA	0	M	-
	0% setting	-2000 to +10000	0	E/S/M	-
	100% setting	-2000 to +10000	1000	E/S/M	-

8 - 2 Explanation of Basic Functions

■ PV Input

● Input type

This item is for setting the type of PV input. In the case of a temperature sensor, set the sensor type and temperature range, and in the case of DC voltage/DC current input, set the type of signal. The DC voltage/DC current range and decimal point position are set in the PV range lower value and PV range upper value items.

Item	Description	Factory Setting	User Level
Input type	See Range Code Table (page 13-3) .	43: 0 to 5V	E/S/M

Note

- On the DMC10, temperature sensor and DC current/voltage signals can be used as PV input. Also, different input types can be assigned to each channel.
- When there is an unused channel, control output and PV alarm are OFF by setting range number “0”. For this reason, wiring to PV input on unused channels is not required.

● Temperature unit

This item is for setting the temperature unit when a temperature sensor is used for the PV input.

The temperature unit can be set for thermocouple unit or RTD unit.

Item	Description	Factory Setting	User Level
Temperature unit	0: °C 1: Special unit	0: °C	M
Related setting item: Input type			

● Decimal point position (when some input types are DC voltage, DC current or RTD, and when some input types are thermocouple on advanced function models)

Set the decimal point position of the range when some input types are DC voltage, DC current or RTD, and when some input types are thermocouple. This setting changes the decimal point position of all related parameters to the setting made here. (Related parameters are: PV, SP, PV-related event setting values, PV bias, SP upper limit, SP lower limit, inter-channel deviation control value, auxiliary output 0%, 100% setting, SP up gradient, and SP down gradient.)

Item	Description	Factory Setting	User Level
Decimal point position	0: With no decimal point 1: 1 decimal digit is indicated 2: 2 decimal digits are indicated 3: 3 decimal digits are indicated	0: With no decimal point	S/M
Related setting item: Input type • PV range lower limit • PV range upper limit • PV-related event setting values, inter-channel deviation control deviation value, auxiliary output 0%, 100% setting, SP up gradient, SP down gradient			

Handling Precautions

- When the decimal point has been changed, each of the already set parameter values must be set again.
Example: SP is 40.0 when the decimal point position is changed to the No.1 position after SP is set to 400.
- When a range whose decimal point cannot be changed has been set, this decimal point position cannot be written by communications.
Example: In the case of range No.1, the decimal point position is fixed to “0”. However, “0” cannot be written.

● **PV range upper/lower value (only when input type is DC voltage or DC current)**

This item is for setting the PV range upper/lower values when the input type is DC voltage or DC current.

Set the indication value when the input signal is the minimum value or maximum value. (In the case of DC 4 to 20mA input, set the minimum value when 4mA is input, and the maximum value when 20mA is input.)

Item	Description	Factory Setting	User Level
PV range lower limit	-2000 to +10000	0	E/S/M
PV range upper limit	2000 to 10000	1000	
Related setting item: Input type • Decimal point position			

● **PV bias**

This item is used when performing PV value offset.

Offset is used when the sensor has deteriorated.

Item	Description	Factory Setting	User Level
PV bias	-2000 to +10000	0	S/M

● **PV filter**

This item is used when the PV value suddenly fluctuates repeatedly and control is not possible, or when the PV value fluctuates minutely due to the influence of noise. In almost all cases, this item can be used at its default, and so it need not be set.

Item	Description	Factory Setting	User Level
PV filter	0.0 to 120.0s	0.0s	M

 **Note**

Minute fluctuation of the PV value leads to sudden fluctuation of the manipulated variable. When the control device is frequently switched ON and OFF, or when the heater current value, for example, that is currently being controlled repeatedly fluctuates suddenly, the PV filter can also be used to stabilize the PV value.

Note, however, that when the PV filter is used, the actual PV value may differ from the apparent PV value due to a delay.

This relationship is shown by the following formula:

$$OUT = OUT_{-1} + (IN - OUT_{-1}) / (T / Ts + 1)$$

PV filter□
 0.0 to 120.0s (0.0 indicates that filter is OFF.)□
 A primary delay digital filter can be applied to PV.

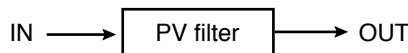

- IN: Input to PV filter
- OUT: Current filter calculation output
- OUT₋₁: Previous filter calculation output
- T: Filter setting value (s)
- Ts: Sampling cycle (500ms)

● **Cold junction compensation operation (at thermocouple input only)**

This item is used when a cold junction compensator such as an ice box is used to perform control more accurately instead of the DMC10's internal cold junction compensation function on a thermocouple.

Item	Description	Factory Setting	User Level
Cold junction compensation action	0: Internal 1: External	0: Internal	M
Related setting item: Input type			

● **Upper SP limit/lower SP limit**

These items are for setting the upper and lower limits of the SP value setting range. SP values outside of the range set here cannot be written.

Item	Description	Factory Setting	User Level
Lower SP limit	PV range lower value to upper SP limit value	PV range lower limit	S/M
Upper SP limit	Lower SP limit value to PV range upper value	PV range upper limit	

● **SP down gradient, SP up gradient, SP down gradient time unit**

These items are for setting the SP up gradient, down gradient and gradient time unit.

In the instances described below, the current PV value is taken to be the start SP value, and the SP value gradually rises (or falls) in the form of a gradient towards the final SP value. These items are used, for example, to make the PV value rise (or fall) gradually.

- When the power is turned ON
- When the MANUAL mode is switched to the AUTO mode
- When the READY mode is switched to the RUN mode
- When auto-tuning ends

In the instance described below, the last SP value in the REMOTE mode is taken to be the start SP, and acts towards the final SP value.

- When the REMOTE mode is switched to the LOCAL mode

When the “currently used SP” is read during SP gradient, the SP value on the gradient is read.

When the “currently used SP” is read during the MANUAL or READY modes, or during AT execution, the target SP (final SP) is read.

Item	Description	Factory Setting	User Level
SP down gradient	0 to 10000	0	M
SP up gradient	0 to 10000	0	
SP gradient time unit	0: unit/min 1: unit/h	0	

❗ **Handling Precautions**

The time accuracy is $\pm 1\%$ of the set time. Pay attention to this during prolonged operation.

■ Control Output

● Control method

Select the control method from the following:

(For details, see “[Appendix, Advice on Control Constants.](#)”)

- ON/OFF control:
By this control method, PV reaches the SP value and PV is repeatedly switched ON and OFF. This control method is used when not much priority is given to controllability as a certain degree of overshoot and undershoot occur.

! Handling Precautions

In actual fact, a certain fixed gap called a “differential” is provided during ON/OFF switching to avoid frequent ON/OFF operation of the control device. The value of this differential can be set within the range 1 to 9999unit.

- Control by self-tuning:
By this control method, the controller automatically tunes the control constants to achieve a stable state when hunting occurs when the SP value is changed or when the control characteristics change.
- Control by PID fixed values:
By this control method, control is performed based upon PID control constants set by auto-tuning or set on the loader. As PID constants are not changed as long as they are not operated, the PID constants must be operated when control is disturbed when the SP value is changed or when the characteristics of the control target change.

Item	Description	Factory Setting	User Level
Control method	0: ON/OFF control 1: Control by self-tuning 2: Control by PID fixed values	0: ON/OFF control	E/S/M

● Control action

Set whether or not to use the DMC10 for heat or cooling control.

- Heat control: By this control method, the manipulated variable is decreased (or turned OFF) accompanying the increase in PV value. This control method is also called “reverse action” as the change in PV value and manipulated variable are in a non-proportional relationship.
- Cooling control: By this control method, the manipulated variable is increased (or turned ON) accompanying the increase in PV value. This control method is also called “direct action” as the change in PV value and manipulated variable are in a directly proportional relationship.

Item	Description	Factory Setting	User Level
Control action	0: Heat control (reverse action) 1: Cooling control (direct action)	0: Heat control (reverse action)	E/S/M

● Time proportional cycle

This item is for setting the time cycle during time proportional control. The value obtained by applying the manipulated variable to this time becomes the ON time. Generally, controllability improves the shorter the time proportional cycle becomes. However, if the cycle is set to a short value, the control device tends to be repeatedly switched ON and OFF frequently, and so the life of the control device must be taken into consideration.

When the cycle is set to 10 seconds or more or when relay output is included in the control operation, ON/OFF operation shorter than 200ms is not performed at all times.

Item	Description	Factory Setting	User Level
Time proportional cycle	5 to 120s (relay output) 1 to 120s (voltage pulse output)	10s	E/S/M
Related setting item: Control method			

● Time proportional operating mode

Set the operating mode during time proportional control:

- Priority on controllability: Priority is given to controllability. When the manipulated variable must be made to fluctuate, control output is controlled to the optimum value while being operated on frequently even if control is within the time proportional cycle.
- Priority on control device life: Only one ON/OFF operation is performed within the time proportional cycle even if the manipulated variable is fluctuating greatly to avoid frequent operation of the control device.

Handling Precautions

We recommend using the time proportional operating mode in combination with lengthening the time proportional cycle to reduce the operating frequency of the control device.

Item	Description	Factory Setting	User Level
Time proportional operating mode	0: Priority on controllability 1: Priority on control device life	0: Priority on controllability	E/S/M
Related setting item: Control method			

● PID initial MV

This is the initial manipulated variable when the power is turned ON, when the READY (control stopped state) is switched to the RUN (control in progress) mode, or when the SP value has been changed.

Item	Description	Factory Setting	User Level
PID initial MV	-10.0 to +110.0%	0.0%	M

● AUTO/MANUAL switching action

This item is for setting the action when the AUTO (automatic control) mode is switched to MANUAL (forced output of a fixed manipulated variable) mode.

The DMC10 has a function for forcibly outputting any manipulated variable set in addition to automatic control. This function can be used, for example, to check operation of a control device while it is running or to hold the temperature of a control device at a fixed output.

- Preset: Any manipulated variable is output when the MANUAL mode is switched to. The manipulated variable at this time is set in the preset manual value item.
- Bumpless: The manipulated variable in the automatic control mode before switching was performed is used as the default.

Item	Description	Factory Setting	User Level
AUTO/MANUAL switching action	0: Bumpless 1: Preset	0: Bumpless	S/M
Related setting item: Preset manual value, Control method			

! Handling Precautions

The MANUAL mode cannot be switched to when the control method is set to ON/OFF control.

● Preset manual value

When the action when the MANUAL mode is switched to the AUTO mode is set to preset, set the manual value (manipulated variable) when switching is performed.

Item	Description	Factory Setting	User Level
Preset manual value	-10.0 to +110.0%	0.0%	S/M
Related setting item: AUTO/MANUAL switching action			

● MV in READY mode

This item is for setting the manipulated variable in the READY (control stopped state) mode not to 0% but to a fixed value. This item is used, for example, in the case of devices that require a certain degree of remaining heat even if control is stopped.

Item	Description	Factory Setting	User Level
MV in READY mode	-10.0 to +110.0%	0.0%	M

● MV at PV alarm occurrence

This item is for setting the manipulated variable when an alarm occurs for the PV input due to a sensor malfunction or line break.

Item	Description	Factory Setting	User Level
MV at PV alarm occurrence	-10.0 to +110.0%	0.0%	M

● **MV rate-of-change limit**

This item is used to suppress fluctuations in the manipulated variable to a fixed manipulated variable or less. It is used when sudden output fluctuations from the controller adversely influence the control device or processing target. Set the limit as the maximum amount of change of the manipulated variable for each output updating cycle, or in the case of the DMC10, the maximum amount of change per 0.5 seconds.

Item	Description	Factory Setting	User Level
MV rate-of-change limit	0.1 to 100.0%	100.0%	M

● **Self-tuning up/down startup condition**

This function disables startup of self-tuning when the PV value is moving down when self-tuning is in use. Use this function for control targets when the characteristics of temperature rise differ greatly from those during temperature fall, and controllability is not required when temperature falls.

Item	Description	Factory Setting	User Level
Self-tuning up/down startup condition	0: Start at both rise and fall of PV value	0: Start at both rise and fall of PV value	M
	1: Start at rise of PV value		
Related setting item: Control method			

● **Self-tuning correction width**

This is the deviation width for starting up self-tuning. When this width is set to “0”, self-tuning by deviation does not start up. (Self-tuning by SP change is started up.)

The self-tuning correction width is set to “0” in the following applications:

- In the case of interference devices (e.g. instruments that are easily influenced by changes in the temperature of adjacent (up, down, left, right) control targets)
- In the case of devices where disturbance is generated intermittently (e.g. packaging equipment)

Item	Description	Factory Setting	User Level
Self-tuning correction width	Thermocouple/RTD: 0.0 to 5.0°C	2.0°C	M
	DC voltage/DC current: 0.0 to 3.0%FS	0.5%FS	

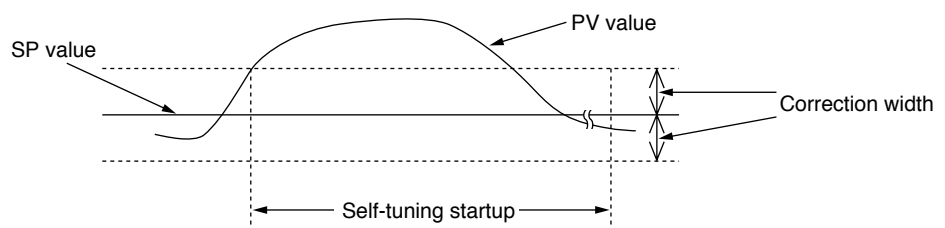

■ SP and Control Parameters

● SP value

This item is for setting the control set point.

The DMC10 holds up to 16 SP values (total of all channels). The SP values can be switched by communications or external switch input. When multiple SP values are used on single channels, “use multi-SP” in “special functions” must be set.

Item	Description	Factory Setting	User Level
SP value	Lower SP limit value to Upper SP limit value	0	E/S/M

● Proportional band (P), Reset time (I), Rate time (D)

This item is for setting control constants proportional band (P), reset time (I), and rate time (D). These constants are automatically set matched to the characteristics of the control target when self-tuning or auto-tuning is used.

Enter these constants manually when the optimum values are already known or when it is difficult to produce the desired effect by self-tuning or auto-tuning.

Item	Description	Factory Setting	User Level
Proportional band (P)	0.1 to 999.9%	5.0%	E/S/M
Reset time (I)	0 to 3600s	120s	
Rate time (D)	0 to 1200s	30s	
Related setting item: Control method			

● MV lower value (OL), MV upper value (OH)

This item is for setting the upper and lower values of the manipulated variable.

Item	Description	Factory Setting	User Level
MV lower value (OL)	-10 to MV upper value	0%	M
MV upper value (OH)	MV lower value to 110%	100%	
Related setting item: Control method			

● Manual reset value (rE)

A deviation occurs between PV and SP when reset time (I) is set to 0 second.

This item is used when a fixed manipulated variable is adjusted to make PV and SP correspond in order to eliminate this deviation (difference between PV and SP).

This item can be set when the control method is set to 1 or 2 (control by PID fixed values) and reset time (I) is set to 0 second.

Item	Description	Factory Setting	User Level
Manual reset value	-10 to +110%	50%	S/M
Related setting item: Control method, Reset time			

● **Differential**

This item is for setting the difference between the ON point and OFF point during ON/OFF control. This item is for avoiding repeatedly turning the control device ON and OFF frequently. Note, however, that the PV value fluctuates greatly and controllability deteriorates if this item is set to too large a value.

Item	Description	Factory Setting	User Level
Differential	1 to 9999unit	5unit	S/M
Related setting item: Control method			

● **Disturbance response coefficient (Quick-FiTTER)**

This item is used to quicken restoration to a stable state to suppress overshoot when disturbance of the same pattern occurs at a fixed cycle. The effect of this item increases the larger the value is set, and the PV value is restored slowly and smoothly.

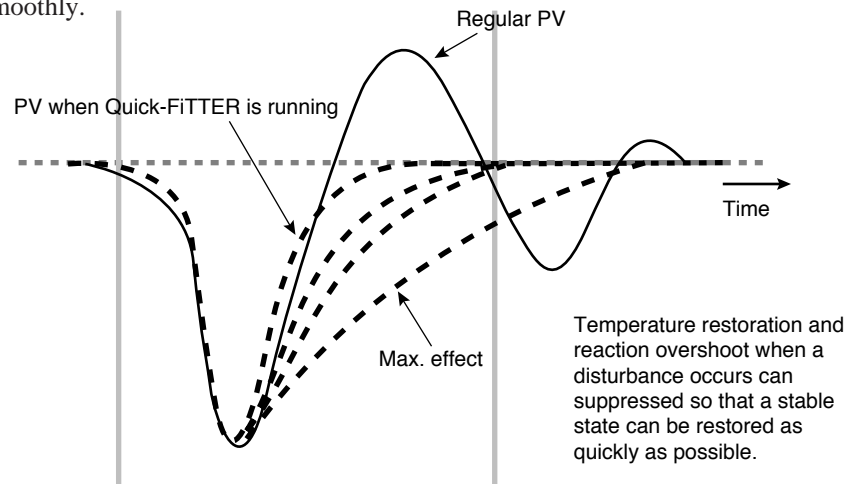

Quick-FiTTER can be used only when the control method is set to control by fixed PID values.

Item	Description	Factory Setting	User Level
Disturbance response coefficient	0 to 30	0	M

■ **Communications**

● **Transmission speed**

This item determines the transmission speed. Normally, we recommend use at the fastest speed of 19200bps. Change the transmission speed before use if the specifications of the communications host device prevent communications from being performed successfully.

Item	Description	Factory Setting	User Level
Transmission speed	0: 2400bps 1: 4800bps 2: 9600bps 3: 19200bps	3: 19200bps	E/S/M

! **Handling Precautions**

Do not connect an external terminator as the DMC10 has a built-in resistor equivalent to a terminator. Connecting an external terminator will prevent communications.

● **Data format**

This item is for setting the format of the communications data. Select the format matched to the specifications of the communications host device.

Item	Description	Factory Setting	User Level
Data format	0: 8bits, even parity, 1 stop bit 1: 8bits, no parity, 2 stop bits	0: 8bits, even parity, 1 stop bit	E/S/M

● **Min. communications response time**

This item is for setting the minimum standby time after a command is received up to return of the response. Though a shorter setting will speed up communications, the setting must be changed to a longer setting when a certain degree of standby time is required depending on the specifications of the communications host device or converter.

Item	Description	Factory Setting	User Level
Min. response time	0: 1ms 1: 10ms 2: 100ms 3: 200ms	1: 10ms	M

● **Min. communications response time added Value(ms)**

The response time set in this parameter is added to the value set for min. communications response time; the total time is the actual min. communications time.

(Example) Setting for min. communications response time = 1 (10 ms)
 Setting for min. communications response time added value = 50 (ms)
 Total min. communications response time = 60 ms

■ **Other**

● **Memory protection**

This function is for prohibiting changes to specific communications parameters. Changes are possible in the loader regardless of the following:

SP: SP values, SP set number
 MODE: RUN/READY, AUTO/MANUAL, auto-tuning start/stop,
 LOCAL/REMOTE

Item	Description	Factory Setting	User Level
Memory protection	0: All writable 1: Only SP, EV, MODE and communications DI writable 2: Only SP, MODE and communications DI writable 3: Not writable except memory protection	0: All writable	E/S/M

● LED operation type

This function is for setting the operation of the POWER lamp on the front panel of the DMC10. Set this item to check the running state during trial running, for example, by the lit/blinking state of the LEDs. Normally, the LED lights at all times when the power is ON.

Item	Description	Factory Setting	User Level
LED operation type	0: Lit at all times 1: Blinking in READY mode 2: Blinking in MANUAL mode 3: Blinking in RSP mode 4: Blinking at self-tuning correction standby 5: Blinking at execution of auto-tuning 6: Blinking at PV alarm occurrence 7: Blinking at memory alarm occurrence 8: SP set selection number blinking *1 9: Blinking during master communications *2 10: Blinking during master/loader communications 11: Control output mode (lit when ON) 12: Event output mode (lit when ON) 13: Event bus output switch mode (lit when ON) 14: External switch input mode (lit when ON) 15: External bus mode (lit when ON) 16: Communications DI input mode (lit when ON) 17: Blinking during inter-channel deviation control 18: Blinking during SP gradient time 19: Blinking during inference of motor control position	0: Lit at all times	M
Related setting item: Channel targeted for LED operation			

*1: By this setting, the LED blinks for the value of the SP number.

*2: By this setting, the LED blinks only during reception at the self device address.

● Channel targeted for LED operation

This item is for setting the channel number targeted for operation when the content set in the LED operation type relates to channel designation.

Item	Description	Factory Setting	User Level
Channel targeted for LED operation	0: OR operation on all channels 1: channel 1 2: channel 2 3: channel 3 4: channel 4	1: channel 1	M
Related setting item: LED operation type			

- The set content varies according to the LED operation type.
- The setting is invalid when the LED operation type is not related to a channel. The setting is invalid when the LED operation type is set as follows:
 - 7: Blinking at memory alarm occurrence
 - 9: Blinking during host communications
 - 10: Blinking during host/loader communication

8 - 3 Detailed Explanation of Option Functions

■ Event Output

The DMC10 is provided with the following event outputs:

- 4 event relay outputs (in case of models w/ options)
- 4 event bus outputs (all models)

By output of these events, the operation state (ON/OFF state) can be read by communications.

For details, see [“Appendix, 2.Advice on Events.”](#)

! Handling Precautions

Event Bus Output

This is event output that can be output from the relays of the event output module via the bus line inside the DMC10 base.

Event bus output is used when physical relay output is required on a 4-channel model that does not have event relay output or when many event outputs are required even on a 2-channel model.

Event bus output can also be used as an internal bit signal even if there is no event output module.

● Operation type

Item	Range						Standby	Latch	Direct/reverse action	Alarm	Action
	Main	Sub	HYS	ON Delay (h:min:s)	OFF Delay (h:min:s)	ch					
0: No event	–	–	–	00:00:00 to 99:59:59	00:00:00 to 99:59:59	1 to 6	–	○	○	○	Event output is always OFF. Event output is forcibly turned OFF even if the latch was being used.
1: PV upper limit	–2000 to +10000	–	0 to 10000	00:00:00 to 99:59:59	00:00:00 to 99:59:59	1 to 4	○	○	○	○	Action on PV value
2: PV lower limit	–2000 to +10000	–	0 to 10000	00:00:00 to 99:59:59	00:00:00 to 99:59:59	1 to 4	○	○	○	○	Action on PV value
3: PV upper/lower limit	–2000 to +10000	Main to Sub	0 to 10000	00:00:00 to 99:59:59	00:00:00 to 99:59:59	1 to 4	○	○	○	○	Action on PV value
4: Deviation upper limit (current reference SP)	–2000 to +10000	–	0 to 10000	00:00:00 to 99:59:59	00:00:00 to 99:59:59	1 to 4	Δ	○	○	○	Action on deviation between SP and PV
5: Deviation lower limit (current reference SP)	–2000 to +10000	–	0 to 10000	00:00:00 to 99:59:59	00:00:00 to 99:59:59	1 to 4	Δ	○	○	○	Action on deviation between SP and PV
6: Deviation upper/lower limit (current reference SP)	0 to 10000	0 to 10000	0 to 10000	00:00:00 to 99:59:59	00:00:00 to 99:59:59	1 to 4	Δ	○	○	○	Action on deviation between SP and PV
7: Inter-channel deviation upper limit	–2000 to +10000	–	0 to 10000	00:00:00 to 99:59:59	00:00:00 to 99:59:59	1 to 4	○	○	○	○	Action on deviation between PV values of two different channels
8: Inter-channel deviation lower limit	–2000 to +10000	–	0 to 10000	00:00:00 to 99:59:59	00:00:00 to 99:59:59	1 to 4	○	○	○	○	Action on deviation between PV values of two different channels
9: Inter-channel deviation upper/lower limit	–2000 to +10000	Main to Sub	0 to 10000	00:00:00 to 99:59:59	00:00:00 to 99:59:59	1 to 4	○	○	○	○	Action on deviation between PV values of two different channels
10: READY mode	–	–	–	00:00:00 to 99:59:59	00:00:00 to 99:59:59	1 to 6	–	○	○	○	The event turns ON when the READY mode is entered.
11: MANUAL mode	–	–	–	00:00:00 to 99:59:59	00:00:00 to 99:59:59	1 to 6	–	○	○	○	The event turns ON when the MANUAL mode is entered.
12: Control action (direct)	–	–	–	00:00:00 to 99:59:59	00:00:00 to 99:59:59	1 to 6	–	○	○	○	The event turns ON when the control action becomes direct action (cooling control).
13: Auto-tuning startup mode	–	–	–	00:00:00 to 99:59:59	00:00:00 to 99:59:59	1 to 6	–	○	○	○	The event turns ON when auto-tuning starts, and is ON until auto-tuning ends.

Item	Range						Standby	Latch	Direct/reverse action	Alarm	Action
	Main	Sub	HYS	ON Delay (h:min:s)	OFF Delay (h:min:s)	ch					
14: Self-tuning correction standby mode	-	-	-	00:00:00 to 99:59:59	00:00:00 to 99:59:59	1 to 6	-	○	○	○	The event turns ON when self-tuning is started with control by self-tuning in an executing state, and stays ON until the control constants are calculated.
15: Loop diagnosis	0 to 10000	-2000 to +10000	0 to 10000	00:00:00 to 99:59:59	00:00:00 to 99:59:59	1 to 4	○	○	○	○	-
16: Timer	-	-	-	00:00:00 to 99:59:59	00:00:00 to 99:59:59	1 to 6 *1	-	○	-	○	ON delay action: Event output turns ON when a preset time has elapsed after the signal (external switch input or internal bit) for timer startup has turned ON. OFF delay action: Event output turns OFF when a preset time has elapsed after the signal (external switch input or internal bit) for timer startup has turned OFF. *1 Designate the PV channel on which the READY mode is monitored when the event has turned OFF in the READY mode. *2 Be sure to set to "0".
17: Heater line break/over-current	0 to Sub	Main to 500	0 to 500	00:00:00 to 99:59:59	00:00:00 to 99:59:59	1 to 2	-	○	○	○	Action on current transformer value. Action only when MV=ON
18: Heater short-circuit	0 to 500	-	0 to 500	00:00:00 to 99:59:59	00:00:00 to 99:59:59	1 to 2	-	○	○	○	Action on current transformer value. Action only when MV=OFF
19: Individual channel, PV alarm	-	-	-	00:00:00 to 99:59:59	00:00:00 to 99:59:59	1 to 6	○	○	○	○	Action on alarm state. The event turns ON while the alarm of the set PV channel is ON.
20: Memory alarm	-	-	-	00:00:00 to 99:59:59	00:00:00 to 99:59:59	-	○	○	○	○	-
21: LOCAL	-	-	-	00:00:00 to 99:59:59	00:00:00 to 99:59:59	1 to 6	○	○	○	○	-
22: SP upper limit	-2000 to +10000	-	0 to 10000	00:00:00 to 99:59:59	00:00:00 to 99:59:59	1 to 4	Δ	○	○	○	-
23: SP lower limit	-2000 to +10000	-	0 to 10000	00:00:00 to 99:59:59	00:00:00 to 99:59:59	1 to 4	Δ	○	○	○	-
24: SP upper/lower limit	-2000 to Sub	Main to 10000	0 to 10000	00:00:00 to 99:59:59	00:00:00 to 99:59:59	1 to 4	Δ	○	○	○	-
25: Deviation upper limit (final reference SP)	-2000 to +10000	-	0 to 10000	00:00:00 to 99:59:59	00:00:00 to 99:59:59	1 to 4	○	○	○	○	-
26: Deviation lower limit (final reference SP)	-2000 to +10000	-	0 to 10000	00:00:00 to 99:59:59	00:00:00 to 99:59:59	1 to 4	○	○	○	○	-
27: Deviation upper/lower limit (final reference SP)	0 to 10000	0 to 10000	0 to 10000	00:00:00 to 99:59:59	00:00:00 to 99:59:59	1 to 4	○	○	○	○	-
28: SP gradient in progress	-	-	-	00:00:00 to 99:59:59	00:00:00 to 99:59:59	1 to 6	○	○	○	○	-
29: Inference of motor control position in progress	-	-	-	00:00:00 to 99:59:59	00:00:00 to 99:59:59	1 to 6	○	○	○	○	-
30: Loop diagnosis 2	-2000 to +10000	-	0 to 10000	00:00:00 to 99:59:59	00:00:00 to 99:59:59	1 to 4	○	○	○	○	-

Δ: Though the normal standby action can be used, the standby action at the time of SP change cannot be used. When a standby action is used in a deviation event, use the event type number 25, 26 or 27.

- When "no function" is selected, the event calculation result (event output) is "0" at all times.
- The channel setting range is as follows:
1 to 4: Designation of PV channel
5: OR operation on all existing channels
6: AND operation on all existing channels
- The channel of the current transformer is displayed for the channel of heater-related events (items 17, 18).
- "-" in the table indicates parameters that do not require setting.
(These parameters can be written, even though they do not have any meaning.)
Event setting value = -2000 to +10000, channels 1 to 6, direct/reverse = 0 to 1 do not influence DMC10 functions even if they are set.
- Enter a value 10X the actual power supply value as the main, sub and HYS of event operation types 17 and 18.
Ex: Becomes 115 in case of 11.5A.

● Operation for each event type

- Including that value
- Not including that value

Item	Direct action	Reverse action															
0: No event	When no function is set, event output turns OFF even if other settings are made. Note, however, that the latch is not released even if the event type = 0.																
1: PV upper limit	Same action as PV lower limit/reverse action 	Same action as PV lower limit/direct action 															
2: PV lower limit	Same action as PV upper limit/reverse action 	Same action as PV upper limit/direct action 															
3: PV upper/lower limit																	
4: Deviation upper limit	Same action as deviation lower limit/reverse action 	Same action as deviation lower limit/direct action 															
5: Deviation lower limit	Same action as event type = 4 (deviation upper limit)/reverse action 	Same action as deviation upper limit/direct action 															
6: Deviation upper/lower limit	Same action as PV upper/lower limit/reverse action 																
7: Inter-channel deviation upper limit	The inter-channel deviation is calculated as follows: <table border="1" style="margin-left: 20px;"> <thead> <tr> <th>Channel Designation</th> <th>2-channel model</th> <th>4-channel model</th> </tr> </thead> <tbody> <tr> <td>1</td> <td>PV1-PV2</td> <td>PV2-PV2</td> </tr> <tr> <td>2</td> <td>PV2-PV1</td> <td>PV2-PV3</td> </tr> <tr> <td>3</td> <td>Not settable</td> <td>PV3-PV4</td> </tr> <tr> <td>4</td> <td>Not settable</td> <td>PV4-PV1</td> </tr> </tbody> </table> Same action as deviation lower limit/reverse action 	Channel Designation	2-channel model	4-channel model	1	PV1-PV2	PV2-PV2	2	PV2-PV1	PV2-PV3	3	Not settable	PV3-PV4	4	Not settable	PV4-PV1	Same action as deviation lower limit/direct action
Channel Designation	2-channel model	4-channel model															
1	PV1-PV2	PV2-PV2															
2	PV2-PV1	PV2-PV3															
3	Not settable	PV3-PV4															
4	Not settable	PV4-PV1															
8: Inter-channel deviation lower limit	The inter-channel deviation is calculated in the same way as the inter-channel calculation target. Action is the same as upper limit/reverse action. 	Action is the same as upper limit/direct action. 															
9: Inter-channel deviation upper/lower limit																	

Item	Direct action	Reverse action	Channel Designation	Notes
10: READY mode	When the READY mode is entered The event state turns ON.	The reverse of direct action is output.	1 to 4: Individual channel designation 5: OR operation on all channels 6: AND operation on all channels	Set "0" for operation in READY mode.
11: MANUAL mode	When the MANUAL mode is entered The event state turns ON.	The reverse of direct action is output.	1 to 4: Individual channel designation 5: OR operation on all channels 6: AND operation on all channels	-
12: Control action (direct)	When control becomes direct action The event state turns ON.	The reverse of direct action is output.	1 to 4: Individual channel designation 5: OR operation on all channels 6: AND operation on all channels	Set "0" as the standby setting.
13: Auto-tuning startup mode	When auto-tuning is started The event state turns ON.	The reverse of direct action is output.	1 to 4: Individual channel designation 5: OR operation on all channels 6: AND operation on all channels	-
14: Self-tuning correction standby mode	During self-tuning correction standby The event state turns ON.	The reverse of direct action is output.	1 to 4: Individual channel designation 5: OR operation on all channels 6: AND operation on all channels	-
15: Loop diagnosis	<p>This event turns ON when no changes in PV value are seen even though control output is ON. This is used to detect malfunctioning of the control device.</p> <ul style="list-style-type: none"> ● Setup items <ul style="list-style-type: none"> • Main setting: Control output value • Sub setting: PV value • ON delay time: Diagnosis time (in case of loop diagnostic event) ● Use of action <ul style="list-style-type: none"> • This turns ON when the PV value set in the sub setting is not reached within the diagnosis time even though a control output value of main setting value or greater is held for the diagnosis time. 			
	<p>Heat control</p> <p>When area conditions 1 and 2 for satisfying the event ON conditions are established, the ON delay is started.</p>	<p>Cooling control</p> <p>When area conditions 1 and 2 for satisfying the event ON conditions are established, the ON delay is started.</p>	1 to 4: Individual channel designation	Standby setting prohibited

Chapter 8. SETUP PARAMETERS (Common to DMC10S and DMC10D)

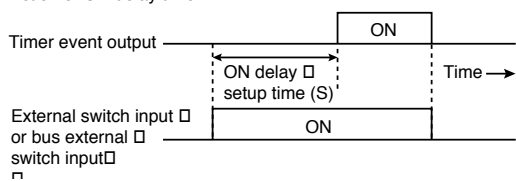
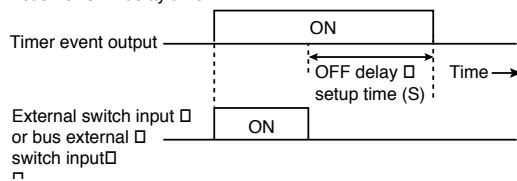
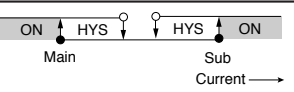
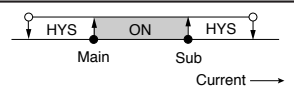
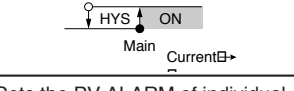
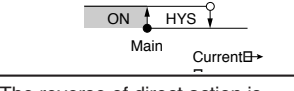
Item	Direct action	Reverse action	Channel Designation	Notes
16: Timer	<p>The timer turns ON when the ON delay time has elapsed after the startup signal has turned ON. The timer turns OFF when the OFF delay timer has elapsed after the startup signal has turned OFF. The "startup signal" here refers to DI such as an external switch input or internal bus</p> <p>• Action of ON delay timer</p>  <p>• Action of OFF delay timer</p>  <p>Other cases The timer starts again from the ON delay default as the timer down counter is reset if the power is turned OFF and then back ON, or if the timer setting value is changed.</p>			
17: Heater line break/over-current			1: channel 1 2: channel 2	Set "0" as the standby setting.
18: Heater short-circuit			1: channel 1 2: channel 2	Set "0" as the standby setting.
19: Individual channel, PV alarm	Sets the PV ALARM of individual channels. (PV upper/lower limit alarm, B line break alarm)	The reverse of direct action is output.	1 to 4: Individual channel designation 5: OR operation on all channels 6: AND operation on all channels	-
20: Memory alarm	Device memory alarms (parameter area RAM checksum, adjustment area EEPROM, RAM checksum) and PV alarms (PV upper limit alarm, lower limit alarm, CJ error, B line break alarm) are targeted, and the event turns ON even if one of the alarms occurs.	The reverse of direct action is output.	Not designated	-
21: LOCAL	When local SP is used, the event state becomes "1".	The reverse of direct action is output.	1 to 2: Individual channel designation 5: OR operation on all channels 6: AND operation on all channels	-
22: SP upper limit	Same action as SP lower limit/reverse action	Same operation as SP lower limit/direct action	-	-
23: SP lower limit	Same action as SP upper limit/reverse action	Same operation as SP upper limit/direct action	-	-
24: SP upper/lower limit	Same action as SP upper limit/reverse action	Same operation as SP upper limit/direct action	-	-

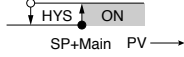
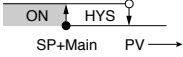
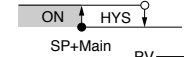
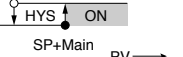
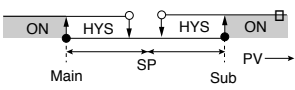
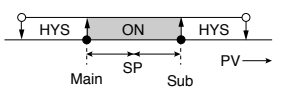
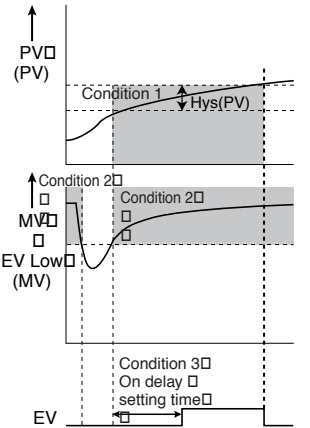
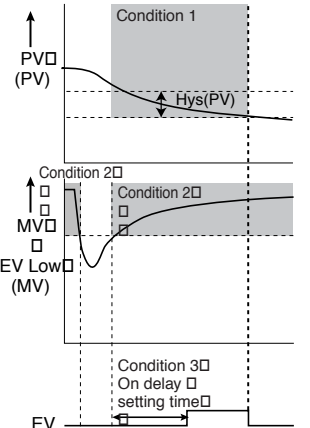
Item	Direct action	Reverse action	Channel Designation	Notes
25: Deviation upper limit (final reference SP)	Same action as deviation lower limit/reverse action 	Same action as deviation lower limit/direct action 	-	-
26: Deviation lower limit (final reference SP)	Same action as deviation upper limit/reverse action 	Same action as deviation upper limit/direct action 	-	-
27: Deviation upper/lower limit (final reference SP)			-	-
28: SP gradient in progress	During SP gradient operation, the event state becomes "1".	The reverse of direct action is output.	1 to 4: Individual channel designation 5: OR operation on all channels 6: AND operation on all channels	-
29: Inference of motor control position in progress	During the inference of motor control position, the event state becomes "1".	The reverse of direct action is output.	1 to 2	-
30: Loop diagnosis 2	<p>Becomes ON when PV does not change though the control output has been turned ON. Used to detect a failure in a operation terminal. This is different from 15: Loop diagnosis in terms of event ON conditions for PV.</p> <ul style="list-style-type: none"> ● Setting items <ul style="list-style-type: none"> • Main setting value: MV • Sub setting value: None • Hysteresis: Deviation from the PV value at the time when the MV has surpassed the main setting value ● Action specifications <ul style="list-style-type: none"> • Becomes ON when the MV is held above the main setting value and the PV has not reached [the PV value at the time when the MV has surpassed the main setting value] plus (minus) [the hysteresis setting value] within the diagnostic time (ON delay time). 			
	<p>In case of heat control</p>  <p>Condition 1 Condition 2</p> <p>EV Low (MV)</p> <p>EV</p> <p>Condition 3 On delay setting time</p> <p>■ The area satisfying the event ON condition. □ ON delay starts when both the conditions 1 and 2 are satisfied.</p>	<p>In case of cool control</p>  <p>Condition 1 Condition 2</p> <p>EV Low (MV)</p> <p>EV</p> <p>Condition 3 On delay setting time</p> <p>■ The area satisfying the event ON condition. □ ON delay starts when both the conditions 1 and 2 are satisfied.</p>	-	-

 **Note**

Event ON delay

An event operation whose condition (exceeding an upper temperature limit, for example) has been satisfied is not activated until a set time has elapsed.

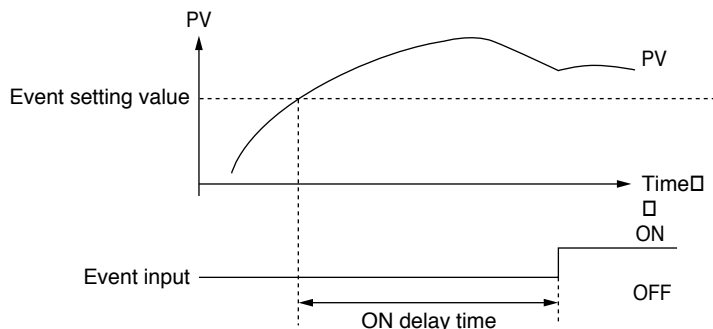

● **Target channel**

Designate the channel targeted for event operation.

- The meaning of the target channel is divided into PV channel and current transformer channel depending on the event type.
- When 5 can be set, all channels are ORed.
- When 6 can be set, all channels are ANDED.
- When PV ALARM OR is set at the same time, the setting of the target channel becomes PV channel selection on PV ALARM OR at the same time. (PV ALARM OR cannot be set separately from the event setting type.)
- In the case of event types for which the target channel need not be set, 1 to 8 can be set, though operation is not influenced even if a target channel is set.

Item	Description	Factory Setting	User Level
Target channel	1 or 2 (in case of 2-channel models) 1 to 4 (in case of 4-channel models)	EV1/EV_BUS1→1 EV2/EV_BUS2→2 EV3/EV_BUS3→3 EV4/EV_BUS4→4	E/S/M

● **Alarm OR action**

When a PV-related alarm for all existing PV channels or a device memory alarm occurs, the state of that event type is ORed to turn the event ON.

When the event type is set to “0”, each of the parameters for the event setting becomes an ALARM OR exclusive setting. By this ALARM OR action, this setting is ignored and output even if standby is set to “ON”. Accordingly, if standby was set to “ON” and the PV alarm occurred immediately after the power was turned ON, the event immediately turns ON (in the case of direct action). Even if reverse action is set, ALARM OR events become direct action at all times. However, in case of standby ON, when changed to READY state, the event becomes OFF.

Item	Description	Factory Setting	User Level
Device alarm OR operation	0: None 1: OR operation used	0: None	M

● **Event setting value (main)**

This is the setting value of the event. The setting value becomes the lower limit value when two values, upper and lower limit, are set according to the event type.

Item	Description	Factory Setting	User Level
Event setting value (main)	According to action type	0	E/S/M

● **Event setting value (sub)**

This is the setting value of the event. The setting value becomes the upper limit value when two values, upper and lower limit, are set according to the event type.

Item	Description	Factory Setting	User Level
Event setting value (sub)	According to action type	1000	E/S/M

● **Hysteresis**

This is the difference between the ON point and OFF point. Use this item to set a value of a certain extent to prevent frequent turning ON and OFF of the event output.

Item	Description	Factory Setting	User Level
Hysteresis	0 to 10000	5	S/M

● **Direct/reverse**

The direct/reverse setting is used to reverse (invert an ON/OFF relationship) the operation of the set event.

Item	Description	Factory Setting	User Level
Direct/reverse	0: Direct action 1: Reverse action	0: Direct	E/S/M

! Handling Precautions

- Direct operation of the PV upper limit and deviation upper limit is the same as the reverse limit of PV lower limit and deviation lower limit operation.

[Example] Event operation type setting: 3 (PV upper and lower limits)
Direct/reverse action setting: 1 (reverse)

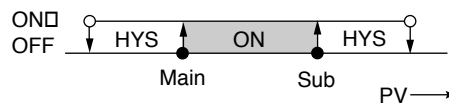

- When using the PV, deviation upper/lower limit and heater line break/overcurrent and control device short-circuit alarm, set HYS so that the OFF point is not lost.

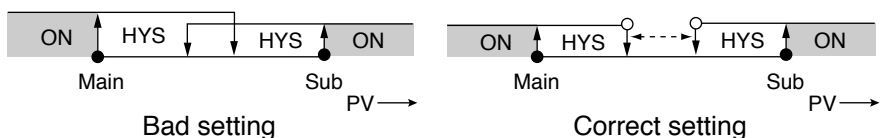

● **Standby**

The standby function prevents an event from turning ON, even when the ON condition of that event is satisfied at controller power ON or when the READY mode changes to the RUN mode.

Standby is activated when an ON condition is satisfied after an OFF condition has been satisfied.

With “2: Standby + standby at SP change,” standby is reset when the SP is changed (SP value is changed or SP set number is changed) in addition to the function of “1: Standby.”

Item	Description	Factory Setting	User Level
Standby	0: None	0: None	S/M
	1: Standby		
	2: Standby + standby at SP change		

● **Latch**

Once event output is ON, the latch function holds an event in the ON state even when an OFF condition is satisfied. Follow the procedure below to reset the latch function at the event OFF condition:

- Set “Latch Release” to the external switch input and turn the external switch ON.
- Turn the power OFF and back ON again.
- Send the latch release message. ([See 1109W on page 10-18.](#))

Item	Description	Factory Setting	User Level
Latch	0: None	0: None	M
	1: Latch operation		

● **Action in READY mode**

Set this item to prevent operation of event output when the controller is in the READY mode.

Item	Description	Factory Setting	User Level
Action in READY mode	0: Action continued in READY mode 1: Action forcibly turned OFF in READY mode	0: Action continued in READY mode	M

■ Current Transformer Input

2-channel models of the DMC10 are provided with a current transformer input function for measuring the current value of a heater. Monitoring the current value flowing to the heater allows you to detect line breaks or overcurrent, and the short-circuit state of control devices such as relays.

● Target channel

Designate the target channel for current transformer input.

As current transformer is designated to each channel as the default, this setting need not be changed when the controller is used on a single-phase power supply. To use the controller on a 3-phase power supply, designate the target channel by this setting item.

Item	Description	Factory Setting	User Level
Target channel	1: OUT1 2: OUT2 3: EV1 4: EV2 5: EV3 6: EV4	CT1→1 CT2→2	M

● Measurement standby time

This item is for setting the time from when control output turns ON up to when measurement of the current value is started.

When a heater line break or overcurrent is detected, the error state is monitored by measuring the current value when the heater is in an ON state. Set this time to a longer value when a large value is detected due to rush current immediately after the control output has turned ON due to the load on the application.

When the ON time of the control output is short, change the setting to reduce the time until measurement.

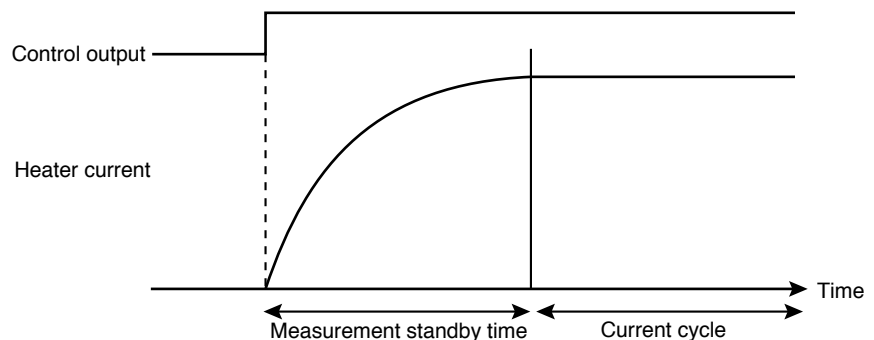

Formula for calculating the standby time

$$\text{Standby time (ms)} = \text{Setting value} \times 10$$

Item	Description	Factory Setting	User Level
Measurement standby time	3 to 30 (x 10ms)	3	E/S/M

■ External Switch Input

When this model supports options, up to four external switch inputs can be used as external switch input functions. On all DMC10 models, four event outputs (EV_BUS1 to EV_BUS4) can be used in the same way as external switch bus inputs (RSW_BUS1 to RSW_BUS4).

 Note

Event bus outputs can be used as external switch bus inputs. Though event bus outputs can also be output from the DMC10 as inputs to an event output module, event bus outputs can be used instead of external switch bus inputs as they are internally on the DMC10. This function enables the following:

- The control output of another channel or all channels is taken as OFF (READY mode) by occurrence of an alarm on a certain channel.
- Control of another channel or all channels is started (READY mode changed to RUN mode) after a certain channel has reached a fixed temperature.
- Control of another channel or all channels is started (RUN mode) or stopped (READY mode) after a fixed time has elapsed.

● Type of action

This item is for setting the action that functions according to external switch input or event output. The same operation can be designated to individual channels and to all channels that are the target of the action.

The action condition for external switch inputs is input at all levels. To continue the action, the input must be held.

Normally, the DMC10 is used in direct action. However, when reverse action is set, the ON and OFF action can be switched. When reverse action is set, the ON and OFF action in descriptions is reversed.

Item	Description	Target channel	Direct/reverse	User Level
Type of action	0: No function 1: "1" added to SP set number 2: "2" added to SP set number 3: "4" added to SP set number 4: RUN/READY 5: AUTO/MANUAL 6: LOCAL/REMOTE 7: Auto-tuning stop/start 8: Self-tuning stop/execution 9: Timer stop/start 10: Release latch state of actual output of event 11: Inter-channel deviation control switching 12: Inter-channel deviation control type 13: External switch input state 14: SP lamp stop	0: All channels 1 to 4: Individual channels or event outputs 1 to 4 5 to 8: Bus output	0: Direct action 1: Reverse action	E/S/M

0: No function

The controller does not function at all even if the assigned external switch input is ON. Note, however, that the ON/OFF state of the assigned external switch input can be read by communications. For this reason, these ON/OFF states can be used for capturing the ON/OFF states of alarms and monitor switches.

- 1: "1" added to SP set number
- 2: "2" added to SP set number
- 3: "4" added to SP set number

The DMC10 can hold up to 16 SP values (eight per channel on 2-channel models and four per channel on 4-channel models).

This item is used to switch these SP values.

Switching of SP values is as follows according to the number of input points used.

1 input: SP1/SP2

2 inputs: SP1 to SP4

3 inputs: SP1 to SP8

Item	Description	SP1	SP2	SP3	SP4	SP5	SP6	SP7	SP8
1 point	External switch input 1	X	○						
2 points	External switch input 1	X	○	X	○				
	External switch input 2	X	X	○	○				
3 points	External switch input 1	X	○	X	○	X	○	X	○
	External switch input 2	X	X	○	○	X	X	○	○
	External switch input 3	X	X	X	X	○	○	○	○

The number of the external switch inputs in the above table may differ.

○: ON, X: OFF

4: RUN/READY

This item is used for switching between the RUN (control) mode and the READY (control stopped) mode.

External switch input	OFF	ON
Device state	RUN	READY

5: AUTO/MANUAL

This item is used for switching the controller from the AUTO (automatic control) mode to the MANUAL (manual operation) mode. For details on related settings, see [page 8-10](#).

External switch input	OFF	ON
Device state	AUTO	MANUAL

! Handling Precautions

The mode cannot be switched to MANUAL when the control method is ON/OFF control.

6: LOCAL/REMOTE

This item can be used on advanced model DMC10D.

This item is used for switching control by local SP to SP by remote SP input.

External switch input	OFF	ON
Device state	LOCAL	REMOTE

7: Auto-tuning stop/start

This item can be used to start and stop auto-tuning of PID constants.

- When this item is turned OFF while auto-tuning has started up, tuning is canceled.
- To normally quit and re-execute auto-tuning after auto-tuning has started up, turn the external switch input OFF then back ON again.

External switch input	OFF	ON
Device state	Auto-tuning stopped	Auto-tuning started



Note

For the auto-tuning of heat/cool control, see ● [Heat/cool control output assignments](#) on page 9-3.

8: Self-tuning start/execution

This item switches between stop and execution of self-tuning.

External switch input	OFF	ON
Device state	Start of self-tuning enabled	Start of self-tuning forbidden



Handling Precautions

To use this function, the “Control method” setting at “Basic functions”- “Control output” must be set to “1: Control by self-tuning.”

9: Timer stop/start

This item becomes the startup signal when the event output type is taken as the timer. When this signal turns ON, the timer count is started, and when this signal turns OFF before the count finishes, the count stops and the count value is reset. Though events are still active after the count has finished, the event action and count value are reset when the startup signal turns OFF.

External switch input	OFF	ON
Device state	Timer count stopped and reset	Timer count started

10: Release latch state

Set this item when using external switch input as release of the event output latch state.

External switch input	OFF	ON
Device state	Holding of latch state enabled	Latch state released

11: Inter-channel deviation control switching

This item can be used on advanced model DMC10D.

This item is used to switch to inter-channel deviation control from regular control.

External switch input	OFF	ON
Device state	Regular control	Inter-channel deviation control

8 - 4 Event Output Special Operation

In event output, output of logical calculations (AND, OR) or port signals as they are is possible by selecting event output special operations in “special functions.”

The following shows a list of setup parameters for event output special operations and describes these parameters: For details on the internal structure of event output special operations, see “[Appendix, Advice on Events.](#)”

■ Setup Parameters (only for event output special operation)

Category	Item Name	Setting Range	Factory Setting	User Level	Remarks
Event type	Type of action	Same as “ action type” of standard event output			See page 8-3.
	Target channel	Same as “ target channel” of standard event output			See page 8-3.
	Alarm OR operation	Same as “ alarm OR operation” of standard event output			See page 8-3.
	Event setting value (main)	Same as “ event setting value (main)” of standard event output			See page 8-3.
	Event setting value (sub)	Same as “ event setting value (sub)” of standard event output			See page 8-3.
	Hysteresis	Same as “ hysteresis” of standard event output			See page 8-3.
	Direct/reverse	Same as “ direct/reverse” of standard event output			See page 8-3.
	Standby	Same as “ standby” of standard event output			See page 8-3.
	ON delay time (h)	Same as “ ON delay (h)” of standard event output			See page 8-4.
	ON delay time (min)	Same as “ ON delay (min)” of standard event output			See page 8-4.
	ON delay time (s)	Same as “ ON delay (s)” of standard event output			See page 8-4.
	OFF delay time (h)	Same as “ OFF delay (h)” of standard event output			See page 8-4.
	OFF delay time (min)	Same as “ OFF delay (min)” of standard event output			See page 8-4.
	OFF delay time (s)	Same as “ OFF delay (s)” of standard event output			See page 8-4.
Event output assignment	Output assignment 1	See detailed explanation on the following pages or Table 10-8.		E/S/M	See page 10-34.
	Output assignment 2	See detailed explanation on the following pages or Table 10-9.		E/S/M	See page 10-34.
	Logic	0:OR 1:AND	0	M	-
	Latch	0:OFF 1:ON (latch in ON) 2:ON (latch in OFF)	0	M	-
	Direct/reverse	0:Direct 1:Reverse	0	M	-
External bus type definitions *	-	0:External bus assigned to be a relay for time proportional operation 1:External bus assigned to receive voltage pulse for time proportional operation	0	M	-

* : External bus type definitions

The DMC10 automatically switches to time proportional operation when it transmits an output signal to an external bus (side connector). (The loader setup screen will look like the example shown below.)

0:External bus assigned to be a relay for time proportional operation.

1:External bus assigned to receive voltage pulse for time proportional operation.

(Example) If the voltage pulse output is set to have a 2-second cycle time and it is transmitted to an external bus (side connector) as specified by the event output assignment, the set external bus definition will prompt one of the following operations:

- If the external bus has been assigned to act as a relay, the cycle time and dead zone of the time proportional calculation function as a relay output.
(Cycle time = 5 seconds for lowest. There will be an on/off dead zone.)
- If the external bus has been assigned to act as a voltage pulse, the cycle time and dead zone of the time proportional calculation operate as a voltage pulse output.

Note: Though the latch was provided for the setup parameters of the standard event outputs, the latch has been moved to event output assignments in event output special operation.

■ Detailed Explanation

The content of each of the items in the event tables is the same as the items for standard event outputs. For details, refer to each of these items.

● Output assignments 1

Of the event output special operations, this setting is for declaring which signal is to be used when logical operations are to be used.

Two or more signals can be selected, and you can select from 32 signals in combination with output assignments 2. Output signals check-marked on the loader are enabled.

Item	Description	Factory Setting	User Level
Output assignment 1	EV_TBL1 internal calculation result	EV_TBL1→EV1	E/S/M
	EV_TBL2 internal calculation result	EV_TBL2→EV2	
	EV_TBL3 internal calculation result	EV_TBL3→EV3	
	EV_TBL4 internal calculation result	EV_TBL4→EV4	
	EV_TBL5 internal calculation result	EV_TBL5→EV BUS1	
	EV_TBL6 internal calculation result	EV_TBL6→EV BUS2	
	EV_TBL7 internal calculation result	EV_TBL7→EV BUS3	
	EV_TBL8 internal calculation result	EV_TBL8→EV BUS4	
	External switch input 1	OUT1 result→OUT1	
	External switch input 2	OUT2 result→OUT2	
	External switch input 3	OUT3 result→OUT3	
	External switch input 4	OUT4 result→OUT4	
	OUT1 control calculation result		
	OUT2 control calculation result		
	OUT3 control calculation result		
	OUT4 control calculation result		

● Output assignment 2

Of the event output special operations, this setting is for declaring which signal is to be used when logical operations are to be used.

Two or more signals can be selected, and you can select from 32 signals in combination with output assignments 1. Output signals check-marked on the loader are enabled.

Item	Description	Factory Setting	User Level
Output assignment 2	RSW_TBL1 internal calculation result	None	E/S/M
	RSW_TBL2 internal calculation result		
	RSW_TBL3 internal calculation result		
	RSW_TBL4 internal calculation result		
	RSW_TBL5 internal calculation result		
	RSW_TBL6 internal calculation result		
	RSW_TBL7 internal calculation result		
	RSW_TBL8 internal calculation result		
	External switching bus input 1		
	External switching bus input 2		
	External switching bus input 3		
	External switching bus input 4		
	Communications DI1		
	Communications DI2		
	Communications DI3		
	Communications DI4		

● **Output assignment 3**

Of the event output special operations, this setting is for declaring which signal is to be used when logical operations are to be used.

Two or more signals can be selected, and you can select from 40 signals in combination with output assignments 1 and 2. Output signals check-marked on the loader are enabled.

Item	Description	Factory Setting	User Level
Output assignment 3	Communications DI5	None	E/S/M
	Communications DI6		
	Communications DI7		
	Communications DI8		
	Communications DI9		
	Communications DI10		
	Communications DI11		
	Communications DI12		
	Undefined		
	Undefined		
	Undefined		
	Undefined		
	Undefined		
	Undefined		

Note: The values ranging from -32768 to +32767 (i.e. 0000H to FFFFH) are writable. However, the undefined bits do not operate because they are reserved. Always set to 0.

● **Logic**

Of the event output special operations, this item is for setting the logical value of signals selected at output assignments 1 and output assignments 2 when logic operations are used.

Item	Description	Factory Setting	User Level
Logic	0: OR 1: AND	0	M

● **Latch**

Of the event output special operations, this item is for setting the latch to the logical output of signals selected at output assignments 1 and output assignments 2. The specifications of this setting are the same as those of the latch for standard event output.

Item	Description	Factory Setting	User Level
Latch	0: OFF 1: ON (latch in ON) 2: ON (latch in OFF)	0	M

● **Direct/reverse**

Of the event output special operations, this item is for setting the polarity of logical value output of the signals selected at output assignments 1 and output assignments 2.

The specifications are the same as direct/reverse for standard event output.

Item	Description	Factory Setting	User Level
Direct/reverse	0: Direct action 1: Reverse action	0	M

8 - 5 External Switch Input Special Operation

In external switch input, logical calculations (AND, OR) can be performed on signals from the input port and other signals by selecting external switch input special operation in “special functions.”

The following shows a list of setup parameters for external switch input special operation and describes these parameters.

For details on the internal structure of external switch input special operations, see [page App.-10](#).

■ Setup Parameters (only external switch input special operations)

Category	Item Name	Setting Range	Factory Setting	User Level	Remarks
External switch input	Type of action	Same as “ action type” of standard external switch input			See page 8-4 .
	Target channel	Same as “ target channel” of standard external switch input			See page 8-4 .
	Input assignment 1	See detailed explanation on the following pages or Table 10-8 .		E/S/M	See page 10-34 .
	Input assignment 2	See detailed explanation on the following pages or Table 10-9 .		E/S/M	See page 10-34 .
	Logic	0: OR 1: AND	0	M	-
	Direct/reverse action	0: Direct 1: Reverse	0	M	-

■ Detailed Explanation

The content of each of the items in the external switch inputs is the same as the items for standard external switch inputs. For details, refer to each of these items.

● Input assignments 1

Of the external switch input special operations, this setting is for declaring which signal is to be used when logical operations are to be used.

Two or more signals can be selected, and you can select from 24 signals in combination with input assignments 2. Input signals check-marked on the loader are enabled.

Item	Description	Factory Setting	User Level
Input assignment 1	External switch input 1	RSW1→RSW_TBL1	E/S/M
	External switch input 2	RSW2→RSW_TBL2	
	External switch input 3	RSW3→RSW_TBL3	
	External switch input 4	RSW4→RSW_TBL4	
	External switching bus input 1	RSW_BUS1→RSW_TBL5	
	External switching bus input 2	RSW_BUS2→RSW_TBL6	
	External switching bus input 3	RSW_BUS3→RSW_TBL7	
	External switching bus input 4	RSW_BUS4→RSW_TBL8	
	EV_TBL1 internal calculation result		
	EV_TBL2 internal calculation result		
	EV_TBL3 internal calculation result		
	EV_TBL4 internal calculation result		
	EV_TBL5 internal calculation result		
	EV_TBL6 internal calculation result		
	EV_TBL7 internal calculation result		
	EV_TBL8 internal calculation result		

● **Input assignments 2**

Of the external switch input special operations, this setting is for declaring which signal is to be used when logical operations are to be used.

Two or more signals can be selected, and you can select from 24 signals in combination with input assignments 1. Input signals check-marked on the loader are enabled.

Item	Description	Factory Setting	User Level
Input assignment 2	Reserved	None	E/S/M
	Reserved		
	Reserved		
	Reserved		
	Reserved		
	Reserved		
	Reserved		
	Reserved		
	Event output 1		
	Event output 2		
	Event output 3		
	Event output 4		
	Communications DI1		
	Communications DI2		
	Communications DI3		
Communications DI4			

● **Input assignment 3**

Item	Description	Factory Setting	User Level
Input assignment 3	Communications DI5	None	E/S/M
	Communications DI6		
	Communications DI7		
	Communications DI8		
	Communications DI9		
	Communications DI10		
	Communications DI11		
	Communications DI12		
	Undefined		
	Undefined		
	Undefined		
	Undefined		
	Undefined		
	Undefined		
	Undefined		
Undefined			

Note: The values ranging from -32768 to +32767 (i.e. 0000H to FFFFH) are writable. However, the undefined bits do not operate because they are reserved. Always set to 0.

! Handling Precautions

“Reserved” is used internally, so be sure to set to “0”.

● **Logic**

Of the external switch input special operations, this setting is for setting the logic of signals selected at input assignments 1 and input assignments 2 when logical operations are to be used.

● **Direct/reverse**

Item	Description	Factory Setting	User Level
Logic	0: OR 1: AND	0	M

Of the external switch input special operations, this item is for setting the polarity of logical value output of the signals selected at input assignments 1 and input assignments 2.

The specifications are the same as direct/reverse for standard external switch inputs.

Item	Description	Factory Setting	User Level
Direct/reverse	0: Direct 1: Reverse	0	M

Chapter 9. SETUP PARAMETERS (DMC10D)

9 - 1 Outline of the Advanced Functions

■ PV Input

On the advanced model DMC10D, some of the thermocouple ranges (for details, see Range List) can be used at the No.1 decimal point. This is more effective for detailed temperature control.

■ Control Output

The following control methods have been added on the advanced model DMC10D.

● Heat/cool control

On 2-channel advanced models (not supported on 4-channel models), two channels' worth of heat/cool control is possible.

Select heat/cool at "special functions" on the loader, and then make each of the settings.

If these settings are not made, heat/cool control will not be possible on the DMC10D. This control method cannot be used jointly with remote SP input or inter-channel deviation control.

● Inter-channel deviation control

This control method makes the temperature of the target object uniform, and function more effectively than conventional loop independent control in applications that interfere with each other.

Set the channel in which this control method is to be implemented to "1" in the internal-channel deviation control parameter in control output in the loader's basic functions.

Then, set the inter-channel deviation control type and inter-channel deviation control deviation value.

● Control by remote SP

By this control method, remote SP can be controlled by signals from an external analog oscillator.

Select remote SP at "special functions" on the loader, and then make each of the settings.

● Position proportional control

Allows position proportional control using the MODUTROL MOTOR.

Select position proportional control at "special functions" on the loader. When this function is selected, RSP control, heat/cool control, power saving and self-tuning cannot be used simultaneously. The motor status can be checked by bit information data (see [page 10-31](#)).

Position proportional control of the following model No. can be selected from the loader:

Model No.	Control status	Position proportional control loop count
DMC10D2XRXXX	FB	1
DMC10D4XRXXX		2
DMC10D2XR01X	No FB	2
DMC10D2XR03X		2
DMC10D4XR00X		2
DMC10D2XRXXX	No FB (When 1-loop's worth is used)	2

Note) FB: Abbreviation of "Feedback wire".

● **Time proportional power saving mode**

Select time proportional power saving mode at "special functions" on the loader. When this function is selected, heat/cool control and inter-channel deviation control cannot be used simultaneously.

● **MV branch control**

Results of an arbitrary channel are applied to the normal MV calculated with PID or a ratio or offset operation is applied to the MV.

9 - 2 Detailed Explanation of Basic Functions

■ Heat/Cool Output Assignments

● Heat/cool output assignments

The output of each loop must be set when performing heat/cool control.

The selection content differs as I/O varies according to the model number.

Item	Description	Factory Setting	User Level
Heat/cool output assignment	0 to 10	0	E/S/M

Relationship between Setting and Output Specifications

(Any relevant function code is acceptable for □ in the Usable Model Numbers column.)

● Heat/cool dead zone

This item is for setting a dead zone between heat side output and cool side output when performing heat/cool control.

Item	Description	Factory Setting	User Level
Heat/cool dead zone	-100.0 to +100.0%	0.10%	E/S/M

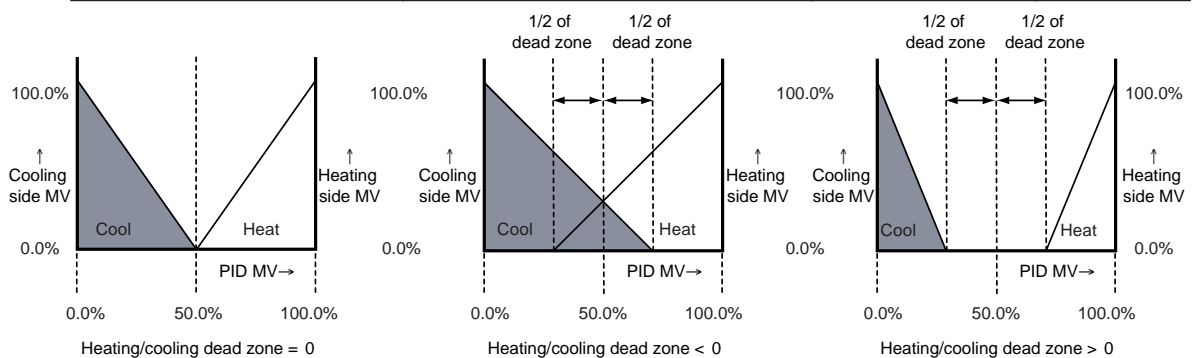

● Heat/cool control AT

When the heat/cool control AT is started, the following operations are performed.

- (1) The AT is started.
- (2) The AT on the Heat side is performed.
- (3) When the AT on the Heat side is terminated, the same PID value as that on the Heat side is also saved on the Cool side.
- (4) Then, the AT on the Cool side is automatically started.

At this time, the output on the Heat side is also automatically output based on the result obtained with the AT on the Heat side.

- (5) When the AT on the Cool side is terminated, the PID value on the Cool side is saved.

! Handling Precautions

- Before interrupting the AT of heat/cool control, set a READY state or MANUAL state.
- At the start of the AT, check that the system is not in an AUTO state or RUN state or there is no PV alarm. In these states, the AT cannot be started. Moreover, when the AT is in operation, if the system enters into these states the AT is stopped.
- When the AT is stopped before (3) above, the PID value before the AT is executed remains. When the AT is stopped in and after the state in (3), a new PID result is saved.

■ Inter-channel Deviation Control

● Inter-channel deviation control

This parameter must be set when performing inter-channel deviation control.

This parameter can be set to ON or OFF on each channel. When this parameter is set to OFF on a channel, regular control is performed on that channel.

Item	Description	Factory Setting	User Level
Inter-channel deviation control	0: OFF 1: ON	0	M

● Designated channel for inter-channel deviation control

This item is for setting which channel is to be the reference channel when performing inter-channel deviation control.

The channel set here becomes the reference channel, and other channels take the deviation of this reference channel as the SP for control.

Item	Description	Factory Setting	User Level
Designated channel for inter-channel deviation control	1 to 2 (2-channel model) 1 to 4 (4-channel model)	ch1→2 ch2, 3, 4→1	M

● Inter-channel deviation control type

This item is for setting whether to perform control by the deviation of PV or SP of the reference channel when performing inter-channel deviation control.

Item	Description	Factory Setting	User Level
Inter-channel deviation control action	0: Designated channel PV + deviation value is taken as SP. 1: Designated channel SP + deviation value is taken as SP.	0	M

0: SP of control loop = PV value of designated channel + inter-channel deviation control deviation value

1: SP of control loop = SP value of designated channel + inter-channel deviation control deviation value

● Inter-channel deviation control deviation value

This item is for setting the deviation value when performing inter-channel deviation control.

Item	Description	Factory Setting	User Level
Inter-channel deviation control deviation value	-2000 to +10000	0	M

■ Control by Remote SP

- When remote SP is set at "special functions" on the loader, it is possible to switch between remote SP and local SP (fixed SP) for each PV channel.
- Switchover between remote SP and local SP is possible by a write through communication or external switch input.

Item Name	Setting Range	Factory Setting	User Level
Remote SP input	0: Not used 1: Used	0: Not used	Displayed on "special functions"
Remote (remote/local switching)	0: Local SP (fixed SP) 1: Remote SP	Remote SP input = 1 Set to " 1" at the time of setting	--

● Assignment of RSP input

When remote SP input is set, the following input assignment is used:

Model	CH1		CH2		CH3		CH4	
	PV	OUT	PV	OUT	PV	OUT	PV	OUT
2	PV1	OUT1	Channel 1 remote SP	Invalid	--	--	--	--
4	PV1	OUT1	PV2	OUT2	Channel 1 remote SP	Invalid	Channel 2 remote SP	Invalid

For terminals, see [page 4-1](#).

● Additional functions

The remote SP input channel can use decimal places, range high/low limit, bias and filter.

ⓘ Handling Precautions

- Match the decimal place of the remote SP input channel with the decimal place of the channel that uses this input.
- Even if +/-10% of the high/low limits of the remote SP input range is exceeded, no input alarm similar to a PV input error is generated.
- Control by remote SP cannot be used together with heat/cool control, inter-channel deviation control or position proportional control.

■ Position Proportional Control

● Position proportional control setting items

Selection by special functions of loader

Item Name	Setting Range	Factory Setting	User Level
Position proportional control Use/type	0: Not used 1: FB + inference 2: FB 3: No FB 4: No FB + powering on position adjustment	0	E/S/M

Setting item before operation

Item Name	Setting Range	Factory Setting	User Level
Position proportional control automatic adjustment	0: Halt/stop 1: Start	0	E/S/M
Position proportional dead zone	0.1 to 25.0%	10.0	
Position proportional adjustment value- Full close	0 to 9999	1000	
Position proportional adjustment value- Full open	0 to 9999	2000	
Full-open time	1 to 250s	30s	
Position proportional motor resistor value	Potentiometer full resistor value 0: Less than 400 ohm 1: 400 ohm to 1000 ohm 2: 1000 ohm to 4000 ohm	0	
Potentiometer long service life	0: Focused on controllability 1: Potentiometer long service life	1	

Items during operation

Item Name	Setting Range	Factory Setting	User Level
Manual operation with no position proportional FB	0: Halt 1 to 9999s: Operation time (s) in open direction 1 to 2000s: Operation time (s) in close direction	0	E/S/M
Motor feedback value	-5.0% to 110.0% (read only)	--	--

Note

If the type of position proportional control is directly written at word address 7275W without using batch writing of the loader, set event output assignment with reference to the table.

Default output buffer when use of position proportional control is selected

Model	Position Proportional Channel	OPEN	CLOSE	FB
2CH	CH1	MV1	MV2	PV2
	CH2(No FB)	MV3	MV4	--
4CH	CH1	MV1	MV3	PV3
	CH2	MV2	MV4	PV4

-
- When "FB" control is used
 - Be sure to perform automatic adjustment.
 - When "FB + inference" is used, inference position control is automatically set when an error is detected in feedback input. For example, in the event of breakage of the feedback wire or feedback error due to deterioration of the potentiometer, position control is continued uninterruptedly, and so this control can be used as a backup operation.
 - In an inference state, the system is restored to the state in which a normal feedback value is used only when a normal state continues under a certain condition while the motor is running.
 - The position of the motor (aperture %) can be checked.
 - When "No FB" is used
 - If "No FB" is used, position proportional control with no FB wire can be performed.
 - Be sure to set "motor full-open time" before use.
 - For "motor full-open time", be sure to set a measured value.
 - When "No FB + power on position adjustment" is used, a difference between the position of the motor and the position inferred by the instrument is eliminated by forcibly outputting a close instruction to the motor by the time set at "motor full-open time" when power is turned on. However, a close instruction is stopped in MANUAL mode, READY mode or in the event of a PV alarm.
 - When a MANUAL state is set, the motor does not operate with a normal manual setting. Set to "Manual operation with No FB". The setting is performed in time units as follows.
 - Time for outputting open instruction: a positive value is written in second units.
 - Time for outputting close instruction: a negative value is written in second units.
 - When a READY state is set,
 - A close instruction is retained when MV in READY state = 0
 - An open instruction is retained when MV in READY state > 0
 - When MV = 0%, 100%, a close instruction and an open instruction are retained.
 - **Position proportional control automatic adjustment**
 - When carrying out position proportional control using the FB wire, be sure to carry out automatic adjustment after all wires are connected correctly. Adjustment can be performed also from the loader setting screen. The operation of the loader is explained in the following item.
 - When adjustment is started, operation automatically shifts from motor full close to motor full open and 3 parameters of position proportional adjustment motor full-close value, motor full-open value and time are automatically set.
 - During control with no FB, automatic adjustment is not available in a MANUAL state or READY state or in the event of FB input error. Moreover, if the system enters into these states during adjustment, the adjustment is stopped.
 - When the adjustment is stopped, the value saved so far is retained.
 - When the following condition is detected, it is judged as an adjustment error and the adjustment result is not saved. In this case, select the most suited input type at "Motor resistor selection".
 - (1) Motor full-open adjustment value - motor full-close adjustment value < 100
 - (2) Motor full-close adjustment value >= 1000

- (3) Motor full-open adjustment value ≥ 1000
- (4) Motor full-open time $< 5(s)$
- When adjustment is not correctly completed such as the motor is stopped at some midpoint without running to the full-close or full-open position, the "motor resistor selection" may not be correct. Change it to a different value and readjust it.

! Handling Precautions

- While the position proportional control function is used, the self-tuning function, heat/cool control, power saving function, remote SP function, etc. cannot be used simultaneously.
- If automatic adjustment cannot be executed because of the status of the apparatus, etc., try adjustment as follows.
 - (1) Set the instrument to the full-close position, read " current FB count (for motor adjustment)" and record it (for the word addresses, see the table below).
 - (2) Set the instrument to the full-open position. Record the time required to reach the full-open state and the motor adjustment value at the time of full open (for the word addresses, see the table below).
 - (3) Manually enter the full-close adjustment value, full-open adjustment value and full-open time at the " Automatic motor adjustment" on the loader and write to the instrument. Or write values at the respective word addresses.

	Position Proportional Control 1	Position Proportional Control 2	Remarks
Current FB count value (for motor adjustment)	1038W	1039 W	Read only
Full-close side adjustment value	7 280W	7 281W	-
Full-open side adjustment value	7 282W	7 283W	-
Full-open time	7 284W	7 285W	-

• **Position proportional operation at loader screen**

It is possible to perform motor adjustment for position proportional control and manual operations from the loader screen.

Item Name		Contents	Remarks
Display update		Starts communication when checked.	-
Setting	Read	Reads adjustment value from the instrument.	-
	Write	Writes adjustment value to the instrument.	-
Automatic adjustment	Start	Starts automatic adjustment.	Displays when type of position proportional control = 1,2.
	Stop	Stops automatic adjustment.	Displays when type of position proportional control = 1,2.
Manual operation	Open	Outputs manual output Open.	Displays when type of position proportional control = 3,4.
	Close	Outputs manual output Close.	Displays when type of position proportional control = 3,4.
	Off	Outputs manual Off Close.	Displays when type of position proportional control = 3,4.
	Auto	Sets normal output.	Displays when type of position proportional control = 3,4.
Channel selection	-	Selects CH1 or CH2.	CH2 cannot be selected when 2-channel model is used and type of position proportional control = 1,2.
Close	-	Closes the screen.	-

• Motor automatic adjustment

Only available when type of position proportional control = 1,2 (with feedback).

Adjustment method:

- (1) Read from the setting screen.
- (2) Select [Setup] → [Automatic motor adjustment].
- (3) Select a CH number (in 2-channel model, only CH1 can be selected).
- (4) Select [Adjustment] → [Start]. Automatic adjustment starts.

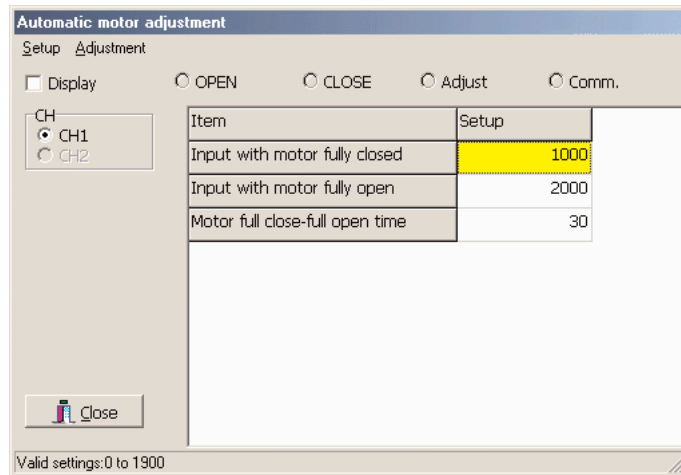

• Motor manual operation

Only available when type of position proportional control = 3,4 (without feedback).

Operation method:

- (1) Read from the setting screen.
- (2) Select [Setup] → [Automatic motor adjustment].
- (3) Press the [Open], [Close], [Off] button.

The same processing can be performed from:

[Manual] → [Open], [Manual] → [Close] or
[Manual] → [Off]

- (4) Press the [Auto] button to return to the normal state.

The same processing can be performed from:

[Manual] → [Auto]

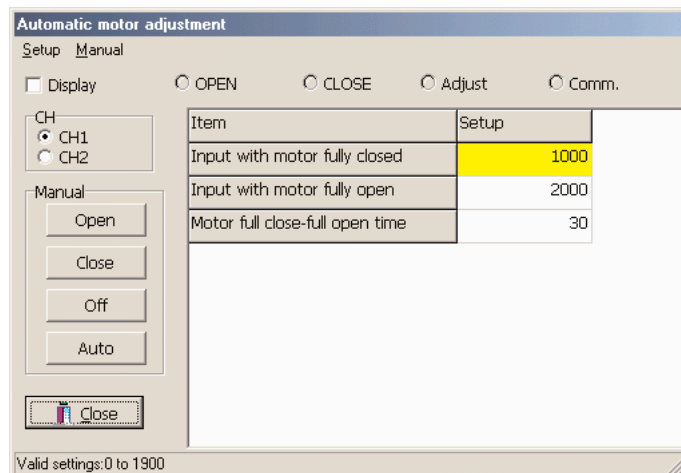

• **Position proportional adjustment value, motor full-close value and motor full-open value**

When FB is used: Set by automatic adjustment, and normally need not be set.

When FB is not used: Check that it is set to the default set value (motor full close = 1000, motor full open = 3000).

• **Full-open time**

When FB is used: Set by automatic adjustment, and normally need not be set.

When FB is not used: Exactly measure the time from motor full close to motor full open and enter the value in second units.

• **Position proportional motor resistor value**

Set it according to the motor resistor value.

• **Potentiometer long service life**

- When potentiometer long service life is set, control is performed by suppressing the frequency of operating the operation terminal and attaching importance to the life of the potentiometer.
- The optimal values of "MV rate-of-change limit" and "position proportional dead zone" of each channel are calculated internally and used. No user-set value is used. These user set parameters are invalidated.

• **Feedback output calculation**

The following output calculations are carried out:

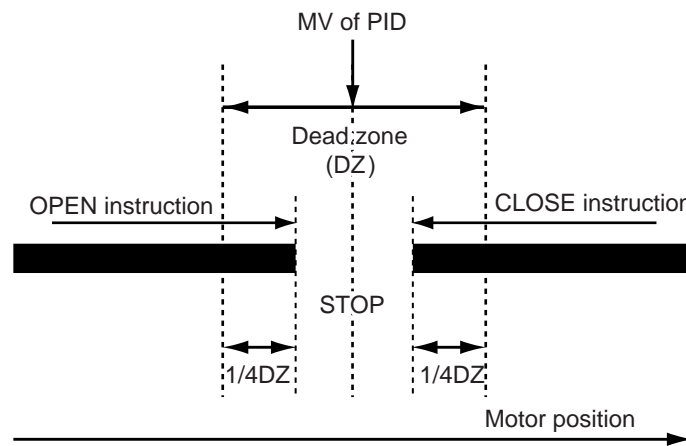

■ Time Proportional Power Saving Mode

Output so that channels with time proportional output are not turned ON simultaneously.

● 1/2 power saving

Current consumption is reduced to 1/2.

In the case of the 2-channel model, the channels are not turned ON simultaneously.

In the case of the 4-channel model, the 2 channels of each pair are not turned ON simultaneously.

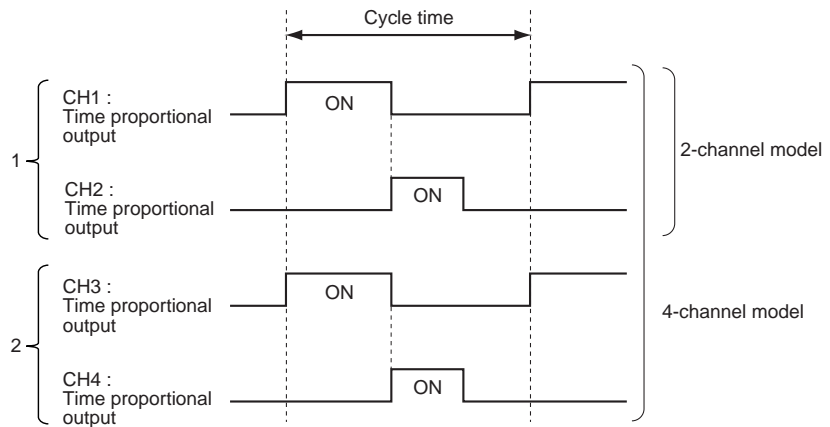

● 1/4 power saving (4-channel model only)

Power consumption is reduced to 1/4.

The 4-channel time proportional outputs are not turned ON simultaneously.

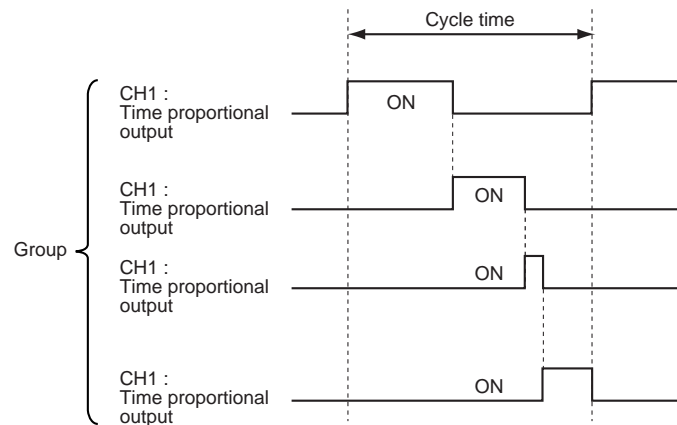

● Delay

If the ON-statuses of the time proportional outputs overlap with each other due to an operation delay of the actuator, set a delay time after the preceding channel is turned OFF until the next channel is turned ON.

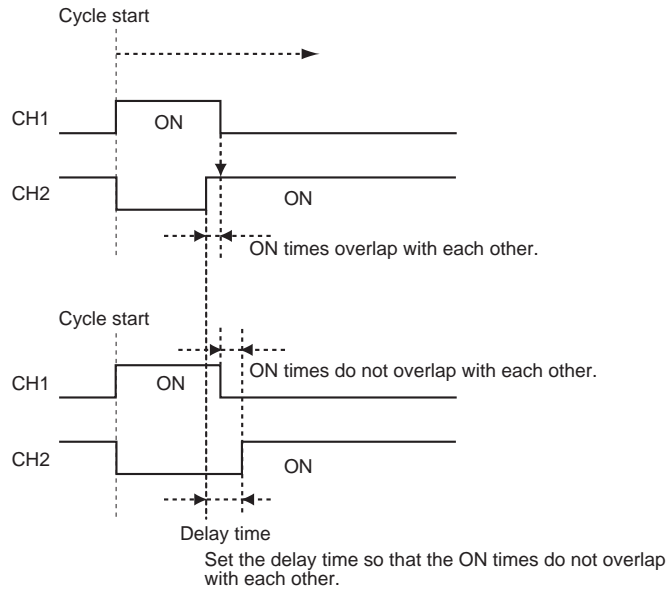

Item Name	Setting Range	Factory Setting	User Level
Power saving time proportional output	2-channel model 0: Not used 1: Used 2: Undefined * 1 4-channel model 0: Not used 1: 1/4 power saving 2: 1/2 power saving * 2	0	Multi-function
Power saving delay time	0 to 1000 (ms)	10	None

* 1 4-channel model only (do not set this for 2-channel model)
* 2 Set this to 1 ms or greater according to the actual instrumentation.

● ON condition of each output channel

- 1/2 power saving

Model	Power Saving Group 1		Power Saving Group 2	
	CH1	CH2	CH3	CH4
2CH	Preferred (master)	When CH1OUT is Off. (slave of CH1)	--	--
4CH	Preferred (master)	When CH1OUT is Off. (slave of CH1)	Preferred (master)	When CH3 is Off. (slave of CH3)

* This is meaningful only for the 4-channel model (can be set, but in the case of a 2-channel model it operates in the same way as if "1" were selected).

- 1/4 power saving

Model	Power Saving Group 1			
	CH1	CH2	CH3	CH4
4CH	Preferred (master)	When CH1OUT is Off. (slave of CH1)	When CH1 and 2 are Off. (slave of CH1,2)	When CH3 is Off. (slave of CH1,2,3)

! Handling Precautions

- ◎ Be sure to check the following settings before using the product.
 - Set the cycle time of the channels of the power saving group to the same value.
 - Be sure to set " operation terminal life-oriented type" .
 - Set the default value for the logical operation setting in output assignment of time proportional output. (Do not set And/Or or inversion).
 - Use it with a fixed PID. (Do not use self-tuning.)
 - This function cannot be used simultaneously with heat/cool control and position proportional control. In this case be sure to set this function to " Not used" .
 - Be sure to set a necessary delay to absorb the delay of the actuator with respect to the channel to be the slave. The delay time varies depending on the actuator used.

- ◎ There are restrictions on the use as follows:
 - If the output of the channel to be the master is large and the output time of the slave channel cannot fall within the cycle time, the output is cut at the last part of the cycle time of the time proportional output on the slave side. Thus, the control calculation result may not be fully output. In such a case, set a high limit to the output with " Output high limit" (OH) at the master channel so that the total output does not exceed 100%. Normally, the following settings are used.
 - In the case of 1/4 power saving,
MV high limit = 25% for all channels
 - In the case of 1/2 power saving,
MV high limit = 50% for all channels
 - In Manual or Ready mode or in the event of a PV alarm, the result of time proportional output, which is output with power saving is given higher priority. Therefore, depending on the MV of the channel to be the master, the set MV may not be output.
 - In the case of a relay output model, the relay may be turned OFF or ON without keeping minimum ON time or minimum OFF time of 200 ms.
 - The sum of the control output and delay time of each channel must be 100% or less at the time of stabilization $PV=SP$. If it exceeds 100%, the channel on the slave side cannot be controlled with the set value.
 - The time proportional MV, which is actually output, is restricted when the set value is changed or when disturbance occurs, and so the response characteristic may change compared with the time proportional output control result when power saving is not used.

MV Branch Control

An arbitrary channel result is used on the normal MV calculated by PID or a ratio or offset calculation is performed on the MV.

- Switching between use/not in use of this function
- Selection of channel to be output
- Ratio with respect to selected MV
- Offset with respect to selected MV

$$MV = \{(MV \text{ of selected channel}) \times (\text{ratio}) + (\text{offset})\} \text{ limited by MV high/low limit}$$

As the MV of the selected channel, the value obtained by applying high/low limit to the MV of the original channel beforehand is used.

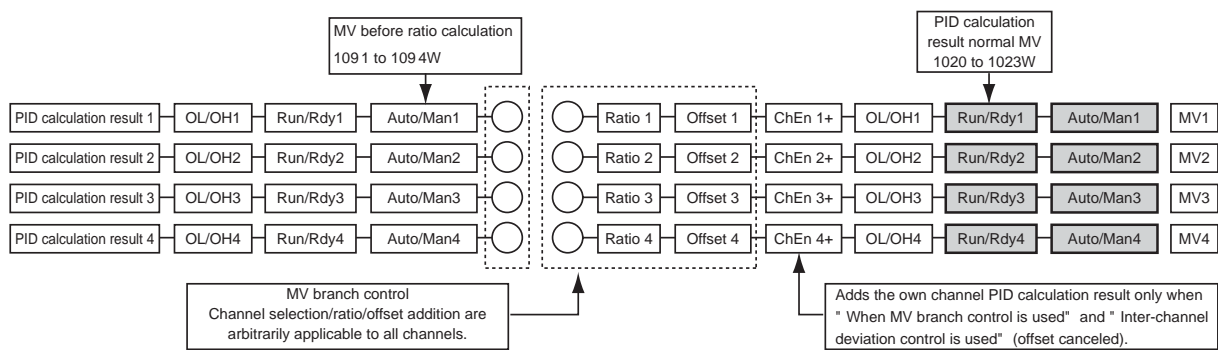

Category	Item Name	Setting Range	Factory Setting	User Level
Control output	Used	0: Not used 1: Used	0	-
	Select channel to be used	1 to 4	CH1 : 1 CH2 : 2 CH3 : 3 CH4 : 4	-
	Ratio	0 to 10000	1000	Use set value x 0.001
	Offset	-2000 to +10000	0	Use set value x 0.1

● Use

In the case of "not used" setting, the set parameters are ignored and factory settings are forcibly used. In this case, other values stored as parameters are not changed.

● Selection of channel

When branch control is performed, set the channel to indicate the calculation result of the PID used.

● Ratio setting

Set a ratio for the MV of the selected channel.
Set value X 0.001 is used as a ratio.

- **Offset setting**

Set the MV of an offset for the MV of the selected channel. The set value x 0.1 is added as an offset.

- **Operation in Ready mode**

When the referencing channel is set to Ready, the master MV = MV in Ready mode. Therefore, the referenced channel also carries out a calculation based on this MV. If the referenced channels are in Ready or Manual mode, the MVs of the respective channels in Ready mode or Manual mode are output.

- **Operation in Manual mode**

When the referencing channel is set to Manual and the referenced channel is AUTO and RUN, the value is obtained by applying a ratio, offset and MV high/low limit to the referenced channel MV = manual MV.

If the referenced channels are in Ready or Manual mode, the MVs of the respective channels in Ready mode or Manual mode are output.

- **Operation combined with inter-channel deviation control**

When "MV Branch output" and "Differential control between channels" are set at the same time, it is possible to erase an offset that cannot be erased by adjustment of an output ratio setting alone.

This adds the PID MV obtained by the differential control between channels calculated by the own channel to the MV calculated by MV branch control.

When the gain of the PID calculation result of the own channel is high, the response characteristic up to the setting improves, but the degree of interference between zones (channels) increases in an interference system.

(Example) When CH1 is followed by CH2

CH2 setting:

- Setting of MV rate-of-change limit
CH specification: 1, ratio = 0.800, offset = 0.0
- Setting of inter-channel deviation control
CH specification = 1, SP = SP of specified CH + inter-channel deviation control deviation
Inter-channel deviation control deviation = 0
- Other PID parameters are set to an appropriate value.

The following operation block diagram is used. The shaded area in the figure indicates parameters whose setting can be changed.

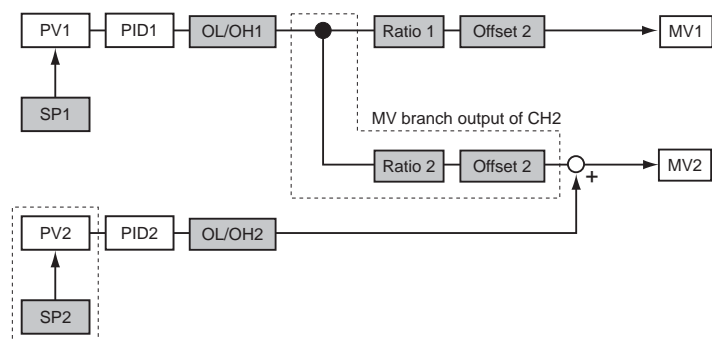

Inter-channel deviation control function of CH2

Chapter 10. COMMUNICATIONS FUNCTIONS

10 - 1 Outline of Communications

The DMC10 is provided with an RS-485 communications function as part of the standard specifications. This enables communications with a personal computer, PLC or other host devices using a user-prepared program. The communications protocol can be selected from the CPL communications, which is the Yamatake's standard, and the MODBUS communications.

This chapter describes the communications common functions and the CPL communications. For the explanation specific to the MODBUS communications, see "[Chapter 11. MODBUS COMMUNICATIONS FUNCTIONS](#)".

■ Features

The features of the DMC10's communications functions are as follows:

- Up to 15 DMC10s can be connected to a single master station as a host device. When 16 or more units are to be used, the communications converter CMC10B (sold separately) is required.
- When the communications specifications of the host device conform to the RS-232C interface, RS-232C/RS-485 conversion can be performed by the communications converter CMC10L (sold separately).
- Almost all of the parameters held by the device can be communicated.

For details on communications parameters, see "[10-8 List of All Communications Parameters](#)" (page 10-16).

- Two types of address arrangements are available for frequently used parameters. Parameter groups that can be handled by single commands can be selected according to the application.
- Random access commands are available. Parameters at addresses separated by a single command can be read or written.
- A maximum transmission speed of 19200bps is supported.

■ Defaults

The following setups are required for starting communications:

Setting item	Setting Location	Setting Range	Factory setting
CPL/MODBUS switching	Set on PC Loader.	0: CPL 1: MODBUS (ASCII format) 2: MODBUS (RTU format)	0: CPL
Device address	Set on rotary switch for device address.	0 to F	-
Transmission speed	Set on PC Loader.	0: 2400bps 1: 4800bps 2: 9600bps 3: 19200bps	3: 19200bps
Data format	Set on PC Loader.	0: 8bits, even parity, 1 stop bit 1: 8bits, no parity, 2 stop bits	0: 8bits, even parity, 1 stop bit
Min. response time	Set on PC Loader.	0: 1ms 1: 10ms 2: 100ms 3: 200ms	1: 10ms

■ Communications Procedures

The communications procedure is as follows:

- (1) The instruction message is sent from the host device (master station) to the DMC10 unit (slave station) to communicate with.
- (2) The slave station receives the instruction message, and performs read or write processing according to the content of the message.
- (3) The slave station sends a message corresponding to the processing content as the response message.
- (4) The master station receives the response message.

Handling Precautions

- CPL and MODBUS can be switched only on the PC loader.
- Even when the MODBUS operating mode has been selected, the CPL communications are used on the loader port side.
- On the host side communications port, it is not possible to use the CPL with the MODBUS ASCII format or the MODBUS RTU format.

10 - 2 Message Structure

■ Message Structure

The following shows the message structure:

Messages are broadly classified into two layers: the data link layer and the application layer.

- Data Link Layer
This layer contains the basic information required for communications such as the destination of the communications message and the check information of the message.
- Application layer
Data is read and written in this layer. The content of the layer varies according to the purpose of the message.

Messages comprise parts (1) to (9) in the figure below.

The command (details sent from the master station) and the response (details returned from the slave station) are stored in the application layer.

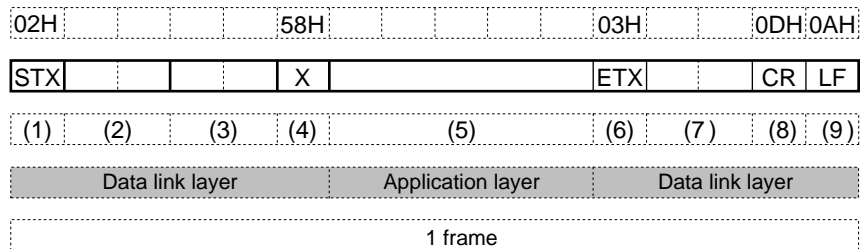

- (1) STX (start of message)
- (2) Station address
- (3) Sub address
- (4) Device ID code
- (5) Send message = command, Response message = response
- (6) ETX (end of command/response)
- (7) Checksum
- (8) CR (delimiter)
- (9) LF (delimiter)

■ Data Link Layer

● Outline

The data link layer is of a fixed length. The position of each data item and the number of its characters are already decided. Note, however, that the data positions of the data link layer from ETX onwards shift according to the number of characters in the application layer. The character length, however, remains unchanged.

● Response start conditions

- The device sends the response message only when (1) message structure, (2) device address, (3) sub address, (4) checksum and (5) message length of a single frame in the data link layer are all correct. If even one of these is incorrect, no response messages are sent, and the device stands by for reception of STX.

ⓘ Handling Precautions

The sub address must be set to 00 (30H, 30H) on the master station.

- Number of Word Addresses Accessible by a Single Frame

Type	Description of Command	RAM Area	EEPROM Area
RS	Decimal format read command	16	16
WS	Decimal format write command	16	16
RD	Hexadecimal format read command	28	28
WD	Hexadecimal format write command	27	16
RU	Hexadecimal format random read command	28	28
WU	Hexadecimal format random write command	14	14

● List of data link layer data definitions

The following list shows the definitions for data in the data link layer:

Data Name	Character Code	Number of Characters	Meaning of Data
STX	02H	1	Start of message
Station address	0 to 0FH are expressed as Hex character codes.	2	Judgement of device to communicate with
Sub address	0 to 07FH are expressed as Hex character codes.	2	No function
Device ID code	"X" (58H) or "x" (78H)	1	Device type
ETX	ETX (03H)	1	End position of application layer
Checksum	00H to FFH are expressed as 2-digit Hex character codes.	2	Checksum of message
CR	0DH	1	End of message (1)
LF	0AH	1	End of message (2)

● Description of data items

- STX (02H)

When STX is received, the device judges this to be the start of the send message. For this reason, the device returns to the initial state whatever reception state it was in, and processing is started on the assumption that the STX of the first character has been received. The purpose of this is to enable recovery of the device's response at the next correct message (e.g. RETRY message) from the master station in the event that noise, for example, causes an error in the sent message.

- Station address

Of the messages sent by the master station, the device creates response messages only when device addresses are the same. Device addresses in messages are expressed as 2-digit hexadecimal characters.

The device address is set by the rotary switch for the device address within the range 0 to F. When 16 or more units are to be used, the communications converter **CMC10B** (sold separately) is required.

When the device address is set to 0 (30H, 30H), the device creates no response even if device addresses match.

The device returns the same device address as that received as the response message.

- Sub address

The **DMC10** does not use the sub address. For this reason, set "00" (30H, 30H). The device returns the same sub address as that received as the response message.

- Device ID code

The device sets X(58H) or x(78H) as the device judgment code. This code is determined for each device series, and other codes cannot be selected. The device returns the same device judgment code as that received as the response message. X(58H) is used as the default, and x(78H) is used for judging the message as the resend message.

- ETX

ETX indicates the end of the application layer.

- Checksum

This value is for checking whether or not some abnormality (e.g. noise) causes the message content to change during communications.

The checksum is expressed as two hexadecimal characters.

- How to create the checksum

1. Add the content of the message from STX through ETX in single byte units.
2. Take 2's complement of the addition results.
3. Convert the result to character codes.

- CR/LF

This indicates the end of the message. Immediately after LF is received, the device immediately stands by for permission to process the received message.

■ Application Layer

The table below shows the configuration of the application layer.

Item	Description
Command	" RS" (read decimal number format continuous address data command)
	" WS" (write decimal number format continuous address data command)
	" RD" (read hexadecimal number format continuous address data command)
	" WS" (write hexadecimal number format continuous address data command)
	" RU" (read hexadecimal number format random address data command)
	" WU" (write hexadecimal number format random address data command)
Data delimiter	RS, WS: " ," (comma) Other commands: None
Word address	RS, WS: " 501W" etc. Other commands: " 01F5" etc.
Number of reads	Numerical value of characters expressed as " 1" for example
Numerical value to be written	RS, WS: Numerical value of characters expressed as " 100" for example Other commands: Numeric value of characters expressed in hexadecimal as " 0064" for example

10 - 3 Description of Commands

■ Read Continuous Data Command (RS command)

This command reads data of continuous addresses. Designated addresses can be applied to actual addresses and virtual addresses.

● Send message

This instruction enables the content of continuous data addresses starting with the specified read start address to be read as a single message. The figure below shows the structure of the application layer of the send message when the data is read.

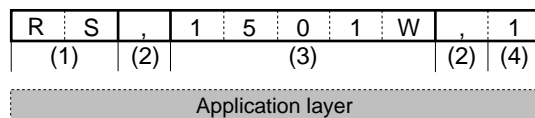

- (1) Read continuous command
- (2) Data delimiter
- (3) Word address
- (4) Number of read data items

● Response message

A response message corresponding to the command content is returned when the message is correctly received.

The figure below shows the structure of the application layer of the response message when the data is read.

● Maximum number of read data items per message

- At normal termination (reading of single data item)

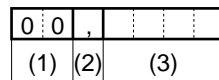

- At normal termination (reading of multiple data items)

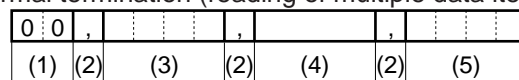

- At abnormal termination

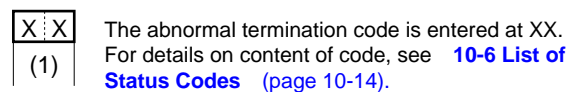

- (1) Status code
- (2) Data delimiter
- (3) Data
- (4) Data 2 to (n-1)
- (5) Data (n)

Up to 16 words for both RAM and EEPROM area

■ Write Continuous Data Command (WS command)

This command writes data to continuous addresses.

● Send message

The figure below shows the structure of the application layer of the send message for the data write instruction.

W	S	,	1	5	0	1	W	,	1	,	6	5
(1)	(2)		(3)				(2)	(4)	(2)	(5)		

- (1) Write command
- (2) Data delimiter
- (3) Start write word address
- (4) Write data (1st word)
- (5) Write data (2nd word)

● Response message

The figure below shows the structure of the application layer of the response message for the data write instruction.

- At normal completion

0	0
(1)	

- At abnormal completion or warning

X	X
(1)	

The abnormal termination code is entered at XX.
For details on content of code, see [10-6 List of Status Codes](#) (page 10-14).

- (1) Status code

● Maximum number of write data items per message

Up to 16 words for both RAM and EEPROM area

■ Read Continuous Fixed Length Data Command (RD command)

This command reads continuous data in 2-byte units. This command is suited to handling of data in ladder programs sent by PLC communications as the data is of a fixed length.

The start data address is expressed as four hexadecimal digits. The number of data items is expressed as four digits, and data is expressed as four x n (n is a plus integer) hexadecimal digits.

● Send message

The read start data address (four hexadecimal digits) and the number of read data items (four hexadecimal digits) are sent.

R	D				
(1)	(2)	(3)			

- (1) Read continuous fixed length command
- (2) Start data word address
- (3) Number of data items

● Response message

If the message is sent successfully, the termination code is taken to be normal (two decimal digits), and the termination code is returned appended with the number of read data (four hexadecimal digits x number of read data items) specified by the command. If message transmission ends in error, the termination code is taken to be in error (two decimal digits) and returned without the read data appended.

- At normal termination (reading of single data item)

0	0		
(1)	(2)		

- At normal completion (reading of multiple data items)

0	0				
(1)	(2)	(3)	(4)		

- At abnormal termination

X	X
(1)	

The abnormal termination code is entered at XX.
For details on content of code, see [10-6 List of Status Codes](#) (page 10-14).

- (1) Status code
- (2) Data
- (3) Data 2 to (n-1)
- (4) Data (n)

● Maximum number of read data items per message

Up to 28 words for both RAM and EEPROM area

■ Write Continuous Fixed Length Data Command (WD command)

This command writes continuous data in 2-byte units. This command is suited to handling of data in ladder programs sent by PLC communications as the data is of a fixed length.

The start data address is expressed as four hexadecimal digits. Data is expressed as four x n (n is a plus integer) hexadecimal digits.

● Send message

The write start data address (four hexadecimal digits) and the number of write data items (four hexadecimal digits x n) are sent.

- Writing of single data item

W	D				
(1)	(2)	(3)			

- Writing of multiple data items

W	D								
(1)	(2)	(3)	(4)	(5)					

- (1) Write continuous fixed length data command
- (2) Start data word address
- (3) Data 1
- (4) Data 2 to Data (n-1)
- (5) Data n

● Response message

If writing is successful, the normal termination code (two decimal digits) is returned. If only part of the data is written, and the remaining data is not written, the warning terminal code (two decimal digits) is returned. If none of the data is written, the abnormal termination code (two decimal digits) is returned.

- At normal completion

0	0
(1)	

- At abnormal completion or warning

X	X
(1)	

The abnormal termination code is entered at XX.
For details on content of code, see [10-6 List of Status Codes](#) (page 10-14).

- (1) Status code

● Maximum number of write data items per message

RAM area: Up to 27 words

EEPROM area: Up to 16 words

■ Read Fixed Length Random Data Command (RU command)

This command reads random (non-continuous) data in 2-byte units.

● Send message

The data address (four hexadecimal digits) of the data to be read is sent in the specified order.

R	U	0	0				
(1)	(2)	(3)	(4)	(5)			

- (1) Read fixed length random data command
- (2) Sub-command: fixed to 00 .
- (3) Data address 1
- (4) Data address 2
- (5) Data address (n)

● Response message

If the message is sent successfully, the termination code is taken to be normal (two decimal digits), and the termination code is returned appended with the number of read data (four hexadecimal digits x number of read data items) specified by the command. If message transmission ends in error, the termination code is taken to be in error (two decimal digits) and returned without the read data appended.

- At normal completion

0	0				
(1)	(2)	(3)	(4)		

- At abnormal termination

X	X				
(1)					

The abnormal termination code is entered at XX.
For details on content of code, see [10-6 List of Status Codes](#) (page 10-14)

- (1) Status code
- (2) Data 1
- (3) Data 2 to (n-1)
- (4) Data (n)

● Maximum number of read data items per message

Up to 28 words for both RAM and EEPROM area

■ Write Fixed Length Random Data Command (WU command)

This command writes data to random (non-continuous) addresses in 2-byte units. Data is expressed as four hexadecimal digits.

The maximum number of data items that can be written by a single command is eight words.

● Send message

Data is sent for the specified number of write data items with the data address (four hexadecimal digits) of the data to be written and the data (four hexadecimal digits) as a pair.

W	U	0	0								
(1)	(2)	(3)	(4)	(5)	(6)						

- (1) Write fixed length random data command
- (2) Sub-command: fixed to 00 .
- (3) Data address 1
- (4) Write data 1
- (5) Data address (n)
- (6) Write data (n)

● Response message

If writing is successful, the normal termination code (two decimal digits) is returned. If only part of the data is written, and the remaining data is not written, the warning terminal code (two decimal digits) is returned. If none of the data is written, the abnormal termination code (two decimal digits) is returned.

- At normal completion

0	0
(1)	

- At abnormal completion or warning

X	X
(1)	

The abnormal termination code is entered at XX.
For details on content of code, see [10-6 List of Status Codes](#) (page 10-14).

- (1) Status code

● Maximum number of write data items per message

Up to 14 words for both RAM and EEPROM area

10 - 4 Definition of Word Addresses

- **RAM and EEPROM area of word addresses**

Word addresses are categorized as follows:

Word address	Name	Remarks
1000W to 4999W	RAM access word address	Reading and writing of these addresses are both performed on RAM. With writing, addresses are stored in RAM. So, the address becomes the EEPROM value when the power is turned OFF then ON again. Note, however, that for some special data the data is stored to EEPROM where it remains.
5000W to 8999W	EEPROM access word address	Reading and writing of these addresses are both performed on EEPROM. When EEPROM is read, the result is the same as having read 1001W to 4999W. With writing, addresses are stored to EEPROM. So, values are restored even if the power is turned OFF then ON again.

Handling Precautions

The number of times that EEPROM can be rewritten is limited (100,000 operations). Accordingly, we recommend writing parameters that are rewritten extremely frequently to RAM that can be infinitely rewritten to. Note, however, that when writing to RAM is performed, the data in EEPROM is transferred to RAM when the power is turned ON again.

- **Write data range**

Writing is not performed and a specific code is returned if the write value exceeds the range determined by parameters.

- **Write conditions**

A fixed end code is returned also when the writing is not possible due to the conditions.

10 - 5 How Numerical Values Are Expressed in the Application Layer

Each of the numerical values in the application layer must be expressed with zero suppressed.

The table below shows specifications, including those obtained when zero suppressed is not performed. Data in send messages at the host must be sent with all zeros suppressed.

● Handling of numerical values and signs

Item	Specifications	Remedy
Numerical value field, sign field	<ul style="list-style-type: none"> In case of RS and WS command, the + sign must not be appended. Append a " -" to express minus numbers. Unwanted 0's and spaces must not be appended. 	Discontinue message processing, and return end code " 99" by the receive message.

● RS and WS commands

Item	Specifications	Remedy
Unwanted space	Cannot be appended.	Discontinue message processing, and return the erroneous end code by the receive message.
Unwanted zero	Cannot be appended.	
Numerical value = zero	Cannot be omitted. Be sure to use " 0".	
Other unwanted characters	Numerical values may be prefixed with a " -" expressing a minus number. This sign cannot be appended to other characters. The " +" sign must not be appended to indicate plus numerical values.	
Range of usable numerical values	-327 68 to +327 67 . Values out of this range are not allowed.	

● RD, WD, RU and WU commands

Item	Specifications	Remedy
Unwanted space	Cannot be appended.	Discontinue message processing, and return the erroneous end code by the receive message.
Unwanted zero	Cannot be appended.	
Numerical value = zero	Cannot be omitted. Be sure to use " 0000".	
Other unwanted characters	Cannot be appended.	
Range of usable numerical values	0000H to FFFFH	

10 - 6 List of Status Codes

The termination code is returned as the response message when an error occurs on the application layer.

Status Code	Description of Error	Processing	Example
00	Normal end	All processes ended normally.	
99	Undefined command	The end code is returned, and message processing is not performed.	AA, 1001W, 1 RX03E80001
22	Value of written data out of range	Processing is continued except on the relevant word address.	WS, 2001W, 3000
23	Writing is not possible depending on the device setting value conditions or device external conditions.	Processing is continued except on the relevant word address.	-
40	Number of read words in error	The end code is returned, and message processing is not performed.	RS, 1001W, A RD03E9 000Z
41	Word address out of range Conversion error Range -327 68 to +327 67 exceeded	The end code is returned, and message processing is not performed.	RS, 100000W, 1 WD0XXX0001
42	Value of data exceeds the out-of-range, data error and 1-word range.	Processing is performed up to the relevant word address, however, processing from then on is not performed.	WS, 2001W, 100, XXX WS, 2001W, 100000 WD03E9 00010XXX

10 - 7 Reception and Transmission Timing

■ Timing Specifications for Instruction and Response Message

When a slave station is connected with the master station directly via the RS-485 or the CMC10L, the following precautions regarding the transmission timing of instruction messages from the master station and response messages from the slave station should be observed.

● Response time-out

The maximum response time from the end of the instruction message transmission by the master station until when the master station receives a response message from the slave station is 2s [(1) in figure]. So, the response time-out should be set to 2s.

Generally, when a response time-out occurs, the instruction message is resent.

● Transmission start time

A wait time of 10ms or more is required before the master station starts to transmit the next instruction message (to the same slave station or a different slave station) after the end of receiving a response message [(2) in figure].

• RS-485 3-wire system

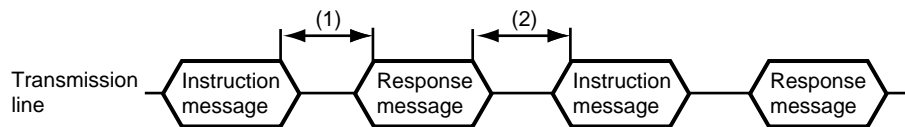

(1) End of master station transmission – Transmission start time of slave station = Max. 2000ms

(2) End of slave station transmission – Transmission start time of master station = Min. 10ms

■ RS-485 Driver Control Timing Specifications

When the transmission/reception on the RS-485 3-wire system is directly controlled by the master station, care should be paid to the following timing.

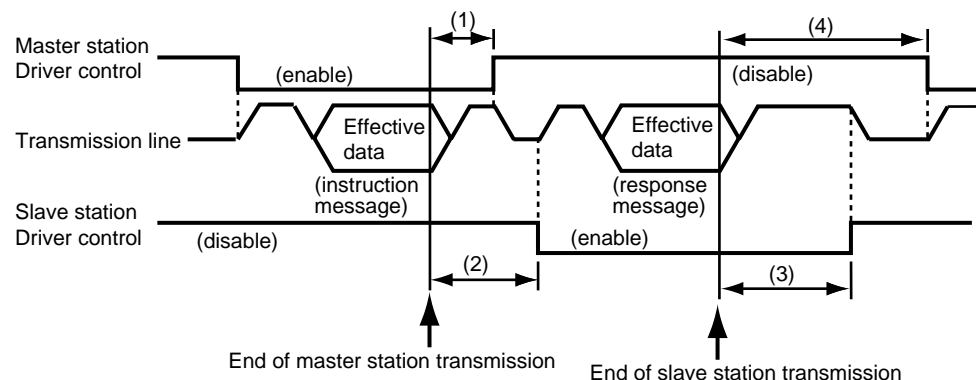

(1) End of master station transmission – Driver disable time = Max. 500 μ s

(2) End of slave station reception – Driver enable time = Min. 1ms

(3) End of slave station transmission – Driver disable time = Max. 10ms

(4) End of master station reception – Driver enable time = Min. 10ms

10 - 8 List of All Communications Parameters (in RAM address order)

Word Address Data

Reading/writing of RAM , ROM

○: Possible

□: Ranges whose PV decimal point position cannot be changed cannot be written. (Example: In the case of PV range No.1, “0” cannot be written to the PV decimal point position.)

X: Not possible

Decimal point information

○: Data is handled according to the content of the data information. (Example: When the PV decimal point position is set to “1” and the conventional PV value is 100.0°C at PV range No.22, the PV value in communications is handled as 1000.)

△: Data is handled as 10X the actual value. (Example: When the actual value is 50.0%, this value is handled as 500 in communications.)

△1: Data is handled as 1000 times the actual value. For example, When the actual value is 1.000, it is handled as 1000 in communications.)

–: The decimal point information is not influenced.

Alias

A word address that is linked to the source word address. Though the content is completely the same, the data arrangement has been changed. For this reason, the word address can be selectively used according to the purpose.

Example: To read the PV values of all channels continuously, word addresses 1004W

Target Channel	Item	RAM address		ROM address		RAM		ROM		Decimal Point Information	Data Information
		Decimal	Hex	Decimal	Hex	R	W	R	W		
–	All alarms representative	1001	03E9H	–	–	○	X	X	X	–	For details, see Table 10-1.
–	PV alarm details	1002	03EAH	–	–	○	X	X	X	–	For details, see Table 10-2.
–	Control-related status	1003	03EBH	–	–	○	X	X	X	–	For details, see Table 10-3.
CH1	PV value	1004	03ECH	–	–	○	X	X	X	○	Varies according to range type and decimal point information.
CH2		1005	03EDH	–	–	○	X	X	X	○	
CH3		1006	03EEH	–	–	○	X	X	X	○	
CH4		1007	03EFH	–	–	○	X	X	X	○	
CH1		1008	03F0H	5008	1390H	○	○	○	○	○	
CH2	SP value in use	1009	03F1H	5009	1391H	○	○	○	○	○	
CH3		1010	03F2H	5010	1392H	○	○	○	○	○	
CH4		1011	03F3H	5011	1393H	○	○	○	○	○	
CH1		1012	03F4H	5012	1394H	○	○	○	○	○	
CH2	SP set number in use	1013	03F5H	5013	1395H	○	○	○	○	○	1 to 4 (4-channel model)
CH3		1014	03F6H	5014	1396H	○	○	○	○	○	1 to 8 (2-channel model)
CH4		1015	03F7H	5015	1397H	○	○	○	○	○	
CH1	Control output value (during regular control)	1020	03FCH	–	–	○	○	X	X	△	–100 to +1100 (10X value)
CH2		1021	03FDH	–	–	○	○	X	X	△	
CH3		1022	03FEH	–	–	○	○	X	X	△	
CH4		1023	03FFH	–	–	○	○	X	X	△	
CH1	Heat side control output value (valid only for heat/cool control)	1024	0400H	–	–	○	X	X	X	△	–100 to +1100 (10X value)
CH2		1025	0401H	–	–	○	X	X	X	△	
CH1	Cooling side control output value (valid only for heat/cool control)	1026	0402H	–	–	○	X	X	X	△	–100 to +1100 (10X value)
CH2		1027	0403H	–	–	○	X	X	X	△	
CH1	AUTO/MANUAL mode	1028	0404H	5028	13A4H	○	○	○	○	–	0: AUTO
CH2		1029	0405H	5029	13A5H	○	○	○	○	–	1: MANUAL
CH3		1030	0406H	5030	13A6H	○	○	○	○	–	
CH4		1031	0407H	5031	13A7H	○	○	○	○	–	
CH1	RUN/READY mode	1032	0408H	5032	13A8H	○	○	○	○	–	0: RUN
CH2		1033	0409H	5033	13A9H	○	○	○	○	–	1: READY
CH3		1034	040AH	5034	13AAH	○	○	○	○	–	
CH4		1035	040BH	5035	13ABH	○	○	○	○	–	
CH1	LOCAL/REMOTE mode	1036	040CH	5036	13ACH	○	○	○	○	–	0: LOCAL
CH2		1037	040DH	5037	13ADH	○	○	○	○	–	1: REMOTE

onwards are handy. To read the data in individual channel units, word addresses

Target Channel	Item	RAM address		ROM address		RAM		ROM		Decimal Point Information	Data Information
		Decimal	Hex	Decimal	Hex	R	W	R	W		
CH1	Count value for motor adjustment	1038	040EH	5038	13AEH	○	×	×	×	—	
CH2		1039	040FH	5039	13AFH	○	×	×	×	—	
CH1	Auto-tuning	1040	0410H	5040	13B0H	○	○	○	○	—	0: Stop 1: Start
CH2		1041	0411H	5041	13B1H	○	○	○	○	—	
CH3		1042	0412H	5042	13B2H	○	○	○	○	—	
CH4		1043	0413H	5043	13B3H	○	○	○	○	—	
—	Internal calculation result of event output/external switch input	1044	0414H	—	—	○	×	×	×	—	For details, see Table 10-4.
—	External switch input state	1045	0415H	—	—	○	×	×	×	—	For details, see Table 10-5.
—	Event output/control output state	1046	0416H	—	—	○	×	×	×	—	For details, see Table 10-6.
CH1	CT value	1047	0417H	—	—	○	×	×	×	△	0 to 500 (10X value)
CH2		1048	0418H	—	—	○	×	×	×	△	
EV1	ON delay timer remaining time (hours)	1051	041BH	5051	13BBH	○	×	×	×	—	
	ON delay timer remaining time (minutes)	1052	041CH	5052	13BCH	○	×	×	×	—	
	ON delay timer remaining time (seconds)	1053	041DH	5053	13BDH	○	×	×	×	—	
EV2	ON delay timer remaining time (hours)	1054	C41EH	5054	13BEH	○	×	×	×	—	
	ON delay timer remaining time (minutes)	1055	041FH	5055	13BFH	○	×	×	×	—	
	ON delay timer remaining time (seconds)	1056	0420H	5056	13C0H	○	×	×	×	—	
EV3	ON delay timer remaining time (hours)	1057	0421H	5057	13C1H	○	×	×	×	—	
	ON delay timer remaining time (minutes)	1058	0422H	5058	13C2H	○	×	×	×	—	
	ON delay timer remaining time (seconds)	1059	0423H	5059	13C3H	○	×	×	×	—	
EV4	ON delay timer remaining time (hours)	1060	0424H	5060	13C4H	○	×	×	×	—	
	ON delay timer remaining time (minutes)	1061	0425H	5061	13C5H	○	×	×	×	—	
	ON delay timer remaining time (seconds)	1062	0426H	5062	13C6H	○	×	×	×	—	
EV5	ON delay timer remaining time (hours)	1063	0427H	5063	13C7H	○	×	×	×	—	
	ON delay timer remaining time (minutes)	1064	0428H	5064	13C8H	○	×	×	×	—	
	ON delay timer remaining time (seconds)	1065	0429H	5065	13C9H	○	×	×	×	—	
EV6	ON delay timer remaining time (hours)	1066	042AH	5066	13CAH	○	×	×	×	—	
	ON delay timer remaining time (minutes)	1067	042BH	5067	13CBH	○	×	×	×	—	
	ON delay timer remaining time (seconds)	1068	042CH	5068	13CCH	○	×	×	×	—	
EV7	ON delay timer remaining time (hours)	1069	C42DH	5069	13CDH	○	×	×	×	—	
	ON delay timer remaining time (minutes)	1070	042EH	5070	13CEH	○	×	×	×	—	
	ON delay timer remaining time (seconds)	1071	042FH	5071	13CFH	○	×	×	×	—	
EV8	ON delay timer remaining time (hours)	1072	0430H	5072	13D0H	○	×	×	×	—	
	ON delay timer remaining time (minutes)	1073	0431H	5073	13D1H	○	×	×	×	—	
	ON delay timer remaining time (seconds)	1074	0432H	5074	13D2H	○	×	×	×	—	
CH1	Proportional band (P)	1075	0433H	5075	13D3H	○	○	○	○	△	1 to 9999 (10X value)
	Reset time (I)	1076	0434H	5076	13D4H	○	○	○	○	—	0 to 3600
	Rate time (D)	1077	0435H	5077	13D5H	○	○	○	○	—	0 to 1200
	Manual reset (RE)	1078	0436H	5078	13D6H	○	○	○	○	—	–10 to +110
CH2	Proportional band (P)	1079	0437H	5079	13D7H	○	○	○	○	△	1 to 9999 (10X value)
	Reset time (I)	1080	0438H	5080	13D8H	○	○	○	○	—	0 to 3600
	Rate time (D)	1081	0439H	5081	13D9H	○	○	○	○	—	0 to 1200
	Manual reset (RE)	1082	043AH	5082	13DAH	○	○	○	○	—	–10 to +110

Chapter 10. COMMUNICATIONS FUNCTIONS

Target Channel	Item	RAM address		ROM address		RAM		ROM		Decimal Point Information	Data Information
		Decimal	Hex	Decimal	Hex	R	W	R	W		
CH3	Proportional band (P)	1083	043BH	5083	13DBH	○	○	○	○	Δ	1 to 9999 (10X value)
	Reset time (I)	1084	043CH	5084	13DCH	○	○	○	○	–	0 to 3600
	Rate time (D)	1085	043DH	5085	13DDH	○	○	○	○	–	0 to 1200
	Manual reset (RE)	1086	043EH	5086	13DEH	○	○	○	○	–	–10 to +110
CH4	Proportional band (P)	1087	043FH	5087	13DFH	○	○	○	○	Δ	1 to 9999 (10X value)
	Reset time (I)	1088	0440H	5088	13E0H	○	○	○	○	–	0 to 3600
	Rate time (D)	1089	0441H	5089	13E1H	○	○	○	○	–	0 to 1200
	Manual reset (RE)	1090	0442H	5090	13E2H	○	○	○	○	–	–10 to +110
CH1	PID operation results (before ratio operation)	1091	0443H	5091	13E3H	○	X	○	X	Δ	
CH2		1092	0444H	5092	13E4H	○	X	○	X	Δ	
CH3		1093	0445H	5093	13E5H	○	X	○	X	Δ	
CH4		1094	0446H	5094	13E6H	○	X	○	X	Δ	
CH1	Manual operation when no position proportional FB is equipped	1095	0447H	5095	13E7H	○	○	○	○	–	
CH2		1096	0448H	5096	13E8H	○	○	○	○	–	
CH1	Motor feedback value	1097	0449H	5097	13E9H	○	X	○	X	Δ	
CH2		1098	044AH	5098	13EAH	○	X	○	X	Δ	
–	Communications DI input (1 to 12)	1100	044CH	5100	13ECH	○	○	○	○	–	0 to 4095
COMM1	Communications DI input	1101	044DH	5101	13EDH	○	○	○	○	–	0, 1
COMM2	Communications DI input	1102	044EH	5102	13EEH	○	○	○	○	–	
COMM3	Communications DI input	1103	044FH	5103	13EFH	○	○	○	○	–	
COMM4	Communications DI input	1104	0450H	5104	13F0H	○	○	○	○	–	
–	Latch release	1109	0455H	–	–	○	○	X	X	–	
COMM1	Communications DI input	1111	0457H	5111	13F7H	○	○	○	○	–	0, 1 Reading/writing of addresses 1101–1104 is done to the same COMM1–4 locations as for addresses 1111–1114 (1101 and 1111 to COMM1, 1102 and 1112 to COMM2, etc.).
COMM2	Communications DI input	1112	0458H	5112	13F8H	○	○	○	○	–	
COMM3	Communications DI input	1113	0459H	5113	13F9H	○	○	○	○	–	
COMM4	Communications DI input	1114	045AH	5114	13FAH	○	○	○	○	–	
COMM5	Communications DI input	1115	045BH	5115	13FBH	○	○	○	○	–	
COMM6	Communications DI input	1116	045CH	5116	13FCH	○	○	○	○	–	
COMM7	Communications DI input	1117	045DH	5117	13FDH	○	○	○	○	–	
COMM8	Communications DI input	1118	045EH	5118	13FEH	○	○	○	○	–	
COMM9	Communications DI input	1119	045FH	5119	13FFH	○	○	○	○	–	
COMM10	Communications DI input	1120	0460H	5120	1400H	○	○	○	○	–	
COMM11	Communications DI input	1121	0461H	5121	1401H	○	○	○	○	–	
COMM12	Communications DI input	1122	0462H	5122	1402H	○	○	○	○	–	
–	All alarms representative	1501	05DDH	–	–	○	X	X	X	–	RAM address: Alias of 1001W
–	PV alarm details	1502	05DEH	–	–	○	X	X	X	–	RAM address: Alias of 1002W
–	Control-related status	1503	05DFH	–	–	○	X	X	X	–	RAM address: Alias of 1003W
CH1	PV value	1504	05E0H	–	–	○	X	X	X	○	RAM address: Alias of 1004W
	SP value in use	1505	05E1H	5505	1581H	○	○	○	○	○	RAM address: Alias of 1008W
	SP set number in use	1506	05E2H	5506	1582H	○	○	○	○	–	RAM address: Alias of 1012W
	Manipulated variable (during regular control)	1507	05E3H	–	–	○	○	X	X	Δ	RAM address: Alias of 1020W
	Manipulated variable of heat side (valid only for heat/cool control)	1508	05E4H	–	–	○	X	X	X	Δ	RAM address: Alias of 1024W
	Manipulated variable of cool side (valid only for heat/cool control)	1509	05E5H	–	–	○	X	X	X	Δ	RAM address: Alias of 1026W
	AUTO/MANUAL mode	1510	05E6H	5510	1586H	○	○	○	○	–	RAM address: Alias of 1028W
	RUN/READY mode	1511	05E7H	5511	1587H	○	○	○	○	–	RAM address: Alias of 1032W
	LOCAL/REMOTE mode	1512	05E8H	5512	1588H	○	○	○	○	–	RAM address: Alias of 1036W
	Auto-tuning stop/start state	1513	05E9H	5513	1589H	○	○	○	○	–	RAM address: Alias of 1040W
	CT value	1514	05EAH	–	–	○	X	X	X	Δ	RAM address: Alias of 1047W
	Proportional band (P)	1515	05EBH	5515	158BH	○	○	○	○	Δ	RAM address: Alias of 1075W
Reset time (I)	1516	05ECH	5516	158CH	○	○	○	○	–	RAM address: Alias of 1076W	
Rate time (D)	1517	05EDH	5517	158DH	○	○	○	○	–	RAM address: Alias of 1077W	
Manual reset (RE)	1518	05EEH	5518	158EH	○	○	○	○	–	RAM address: Alias of 1078W	
CH2	PV value	1519	05F0H	–	–	○	X	X	X	○	RAM address: Alias of 1005W
	SP value in use	1520	05F0H	5520	1590H	○	○	○	○	○	RAM address: Alias of 1009W
	SP set number in use	1521	05F1H	5521	1591H	○	○	○	○	–	RAM address: Alias of 1013W
	Manipulated variable (during regular control)	1522	05F2H	–	–	○	○	X	X	Δ	RAM address: Alias of 1021W
	Manipulated variable of heat side (valid only for heat/cool control)	1523	05F3H	–	–	○	X	X	X	Δ	RAM address: Alias of 1025W

Target Channel	Item	RAM address		ROM address		RAM		ROM		Decimal Point Information	Data Information
		Decimal	Hex	Decimal	Hex	R	W	R	W		
CH2	Manipulated variable of cool side (valid only for heat/cool control)	1524	05F4H	—	—	○	X	X	X	△	RAM address: Alias of 1027W
	AUTO/MANUAL mode	1525	05F5H	5525	1595H	○	○	○	○	—	RAM address: Alias of 1029W
	RUN/READY mode	1526	05F6H	5526	1596H	○	○	○	○	—	RAM address: Alias of 1033W
	LOCAL/REMOTE mode	1527	05F7H	5527	1597H	○	○	○	○	—	RAM address: Alias of 1037W
	Auto-tuning stop/start state	1528	05F8H	5528	1598H	○	○	○	○	—	RAM address: Alias of 1041W
	CT value	1529	05F9H	—	—	○	X	X	X	△	RAM address: Alias of 1048W
	Proportional band (P)	1530	05FAH	5530	159AH	○	○	○	○	△	RAM address: Alias of 1079W
	Reset time (I)	1531	05FBH	5531	159BH	○	○	○	○	—	RAM address: Alias of 1080W
	Rate time (D)	1532	05FCH	5532	159CH	○	○	○	○	—	RAM address: Alias of 1081W
Manual reset (RE)	1533	05FDH	5533	159DH	○	○	○	○	—	RAM address: Alias of 1082W	
CH3	PV value	1534	05FEH	—	—	○	X	X	X	○	RAM address: Alias of 1006W
	SP value in use	1535	05FFH	5535	159FH	○	○	○	○	○	RAM address: Alias of 1010W
	SP set number in use	1536	0600H	5536	15A0H	○	○	○	○	—	RAM address: Alias of 1014W
	Manipulated variable (during regular control)	1537	0601H	—	—	○	○	X	X	△	RAM address: Alias of 1022W
	AUTO/MANUAL mode	1540	0604H	5540	15A4H	○	○	○	○	—	RAM address: Alias of 1030W
	RUN/READY mode	1541	0605H	5541	15A5H	○	○	○	○	—	RAM address: Alias of 1034W
	Auto-tuning stop/start state	1543	0607H	5543	15A7H	○	○	○	○	—	RAM address: Alias of 1042W
	Proportional band (P)	1545	0609H	5545	15A9H	○	○	○	○	△	RAM address: Alias of 1083W
	Reset time (I)	1546	060AH	5546	15AAH	○	○	○	○	—	RAM address: Alias of 1084W
Rate time (D)	1547	060BH	5547	15ABH	○	○	○	○	—	RAM address: Alias of 1085W	
Manual reset (RE)	1548	060CH	5548	15ACH	○	○	○	○	—	RAM address: Alias of 1086W	
CH4	PV value	1549	060DH	—	—	○	X	X	X	○	RAM address: Alias of 1007W
	SP value in use	1550	060EH	5550	15AEH	○	○	○	○	○	RAM address: Alias of 1011W
	SP set number in use	1551	060FH	5551	15AFH	○	○	○	○	—	RAM address: Alias of 1015W
	Manipulated variable (during regular control)	1552	0610H	5552	15B0H	○	○	X	X	△	RAM address: Alias of 1023W
	AUTO/MANUAL mode	1555	0613H	5555	15B3H	○	○	○	○	—	RAM address: Alias of 1031W
	RUN/READY mode	1556	0614H	5556	15B4H	○	○	○	○	—	RAM address: Alias of 1035W
	Auto-tuning stop/start state	1558	0616H	5558	15B6H	○	○	○	○	—	RAM address: Alias of 1043W
	Proportional band (P)	1560	0618H	5560	15B8H	○	○	○	○	△	RAM address: Alias of 1087W
	Reset time (I)	1561	0619H	5561	15B9H	○	○	○	○	—	RAM address: Alias of 1088W
Rate time (D)	1562	061AH	5562	15BAH	○	○	○	○	—	RAM address: Alias of 1089W	
Manual reset (RE)	1563	061BH	5563	15BBH	○	○	○	○	—	RAM address: Alias of 1090W	
CH1	SP value (No.1 SP)	2001	07D1H	6001	1771H	○	○	○	○	○	Varies according to range type and decimal point information.
	SP value (No.2 SP)	2002	07D2H	6002	1772H	○	○	○	○	○	
	SP value (No.3 SP)	2003	07D3H	6003	1773H	○	○	○	○	○	
	SP value (No.4 SP)	2004	07D4H	6004	1774H	○	○	○	○	○	
	SP value (No.5 SP) *	2005	07D5H	6005	1775H	○	○	○	○	○	
	SP value (No.6 SP) *	2006	07D6H	6006	1776H	○	○	○	○	○	
	SP value (No.7 SP) *	2007	07D7H	6007	1777H	○	○	○	○	○	
CH2	SP value (No.1 SP)	2009	07D9H	6009	1779H	○	○	○	○	○	Varies according to range type and decimal point information.
	SP value (No.2 SP)	2010	07DAH	6010	177AH	○	○	○	○	○	
	SP value (No.3 SP)	2011	07DBH	6011	177BH	○	○	○	○	○	
	SP value (No.4 SP)	2012	07DCH	6012	177CH	○	○	○	○	○	
	SP value (No.5 SP) *	2013	07DDH	6013	177DH	○	○	○	○	○	
	SP value (No.6 SP) *	2014	07DEH	6014	177EH	○	○	○	○	○	
	SP value (No.7 SP) *	2015	07DFH	6015	177FH	○	○	○	○	○	
CH3	SP value (No.1 SP)	2017	07E1H	6017	1781H	○	○	○	○	○	Varies according to range type and decimal point information.
	SP value (No.2 SP)	2018	07E2H	6018	1782H	○	○	○	○	○	
	SP value (No.3 SP)	2019	07E3H	6019	1783H	○	○	○	○	○	
	SP value (No.4 SP)	2020	07E4H	6020	1784H	○	○	○	○	○	
CH4	SP value (No.1 SP)	2025	07E9H	6025	1789H	○	○	○	○	○	Varies according to range type and decimal point information.
	SP value (No.2 SP)	2026	07EAH	6026	178AH	○	○	○	○	○	
	SP value (No.3 SP)	2027	07EBH	6027	178BH	○	○	○	○	○	
	SP value (No.4 SP)	2028	07ECH	6028	178CH	○	○	○	○	○	

* Enabled only on 2-channel models

Chapter 10. COMMUNICATIONS FUNCTIONS

Target Channel	Item	RAM address		ROM address		RAM		ROM		Decimal Point Information	Data Information	
		Decimal	Hex	Decimal	Hex	R	W	R	W			
CH1 or H/C *	Proportional band (P)	2101	0835H	6101	17D5H	○	○	○	○	Δ	1 to 9999 (10X value)	
	Reset time (I)	2102	0836H	6102	17D6H	○	○	○	○	–	0 to 3600	
	Rate time (D)	2103	0837H	6103	17D7H	○	○	○	○	–	0 to 1200	
	CH1 heat	MV lower value (OL)	2104	0838H	6104	17D8H	○	○	○	○	–	–10 to +110
		MV upper value (OH)	2105	0839H	6105	17D9H	○	○	○	○	–	
		Manual reset (RE)	2106	083AH	6106	17DAH	○	○	○	○	–	
		Disturbance response coefficient	2112	0840H	6112	17E0H	○	○	○	○	–	
Differential (DIFF)	2114	0842H	6114	17E2H	○	○	○	○	○	Varies according to decimal point information		
CH2 or H/C *	Proportional band (P)	2115	0843H	6115	17E3H	○	○	○	○	Δ	1 to 9999 (10X value)	
	Reset time (I)	2116	0844H	6116	17E4H	○	○	○	○	–	0 to 3600	
	Rate time (D)	2117	0845H	6117	17E5H	○	○	○	○	–	0 to 1200	
	CH2 heat	MV lower value (OL)	2118	0846H	6118	17E6H	○	○	○	○	–	–10 to +110
		MV upper value (OH)	2119	0847H	6119	17E7H	○	○	○	○	–	
		Manual reset (RE)	2120	0848H	6120	17E8H	○	○	○	○	–	
		Disturbance response coefficient	2126	084EH	6126	17EEH	○	○	○	○	–	
Differential (DIFF)	2128	0850H	6128	17F0H	○	○	○	○	○	Varies according to decimal point information		
CH3 or H/C *	Proportional band (P)	2129	0851H	6129	17F1H	○	○	○	○	Δ	1 to 9999 (10X value)	
	Reset time (I)	2130	0852H	6130	17F2H	○	○	○	○	–	0 to 3600	
	Rate time (D)	2131	0853H	6131	17F3H	○	○	○	○	–	0 to 1200	
	CH1 cool	MV lower value (OL)	2132	0854H	6132	17F4H	○	○	○	○	–	–10 to +110
		MV upper value (OH)	2133	0855H	6133	17F5H	○	○	○	○	–	
		Manual reset (RE)	2134	0856H	6134	17F6H	○	○	○	○	–	
		Disturbance response coefficient	2140	085CH	6140	17FCH	○	○	○	○	–	
Differential (DIFF)	2142	085EH	6142	17FEH	○	○	○	○	○	Varies according to decimal point information		
CH4 or H/C *	Proportional band (P)	2143	085FH	6143	17FFH	○	○	○	○	Δ	1 to 9999 (10X value)	
	Reset time (I)	2144	0860H	6144	1800H	○	○	○	○	–	0 to 3600	
	Rate time (D)	2145	0861H	6145	1801H	○	○	○	○	–	0 to 1200	
	CH2 cool	MV lower value (OL)	2146	0862H	6146	1802H	○	○	○	○	–	–10 to +110
		MV upper value (OH)	2147	0863H	6147	1803H	○	○	○	○	–	
		Manual reset (RE)	2148	0864H	6148	1804H	○	○	○	○	–	
		Disturbance response coefficient	2154	086AH	6154	180AH	○	○	○	○	–	
Differential (DIFF)	2156	086CH	6156	180CH	○	○	○	○	○	Varies according to decimal point information		
EV1	Event 1 setting value (main)	2901	0B55H	6901	1AF5H	○	○	○	○	–	RAM address: Alias of 3004W	
	Event 1 setting value (sub)	2902	0B56H	6902	1AF6H	○	○	○	○	–	RAM address: Alias of 3005W	
EV2	Event 2 setting value (main)	2903	0B57H	6903	1AF7H	○	○	○	○	–	RAM address: Alias of 3021W	
	Event 2 setting value (sub)	2904	0B58H	6904	1AF8H	○	○	○	○	–	RAM address: Alias of 3022W	
EV3	Event 3 setting value (main)	2905	0B59H	6905	1AF9H	○	○	○	○	–	RAM address: Alias of 3038W	
	Event 3 setting value (sub)	2906	0B5AH	6906	1AFAH	○	○	○	○	–	RAM address: Alias of 3039W	
EV4	Event 4 setting value (main)	2907	0B5BH	6907	1AFBH	○	○	○	○	–	RAM address: Alias of 3055W	
	Event 4 setting value (sub)	2908	0B5CH	6908	1AFCH	○	○	○	○	–	RAM address: Alias of 3056W	
EV bus1	Event 5 setting value (main)	2909	0B5DH	6909	1AFDH	○	○	○	○	–	RAM address: Alias of 3072W	
	Event 5 setting value (sub)	2910	0B5EH	6910	1AFEH	○	○	○	○	–	RAM address: Alias of 3073W	
EV bus2	Event 6 setting value (main)	2911	0B5FH	6911	1AFFH	○	○	○	○	–	RAM address: Alias of 3089W	
	Event 6 setting value (sub)	2912	0B60H	6912	1B00H	○	○	○	○	–	RAM address: Alias of 3090W	
EV bus3	Event 7 setting value (main)	2913	0B61H	6913	1B01H	○	○	○	○	–	RAM address: Alias of 3106W	
	Event 7 setting value (sub)	2914	0B62H	6914	1B02H	○	○	○	○	–	RAM address: Alias of 3107W	
EV bus4	Event 8 setting value (main)	2915	0B63H	6915	1B03H	○	○	○	○	–	RAM address: Alias of 3123W	
	Event 8 setting value (sub)	2916	0B64H	6916	1B04H	○	○	○	○	–	RAM address: Alias of 3124W	

* H/C: when setting heat/cool control

Target Channel	Item	RAM address		ROM address		RAM		ROM		Decimal Point Information	Data Information
		Decimal	Hex	Decimal	Hex	R	W	R	W		
EV1	Type of action	3001	0BB9H	7001	1B59H	○	○	○	○	-	0 to 28
	Target channel	3002	0BBAH	7002	1B5AH	○	○	○	○	-	1 to 4
	Alarm OR operation	3003	0BBBH	7003	1B5BH	○	○	○	○	-	0: OFF, 1: ON
	Event setting value (main)	3004	0BBCH	7004	1B5CH	○	○	○	○	-	-2000 to +10000 (Varies according to type selection.)
	Event setting value (sub)	3005	0BBDH	7005	1B5DH	○	○	○	○	-	
	Hysteresis	3006	0BBEH	7006	1B5EH	○	○	○	○	-	0 to 10000 (Varies according to type selection.)
	Direct/reverse	3007	0BBFH	7007	1B5FH	○	○	○	○	-	0: Direct action 1: Reverse action
	Standby	3008	0BC0H	7008	1B60H	○	○	○	○	-	0: None, 1: Standby 2: Reset at SP change
	Event action in READY mode	3010	0BC2H	7010	1B62H	○	○	○	○	-	0: Continued, 1: Forcibly OFF
	ON delay time (h)	3011	0BC3H	7011	1B63H	○	○	○	○	-	0 to 99
	ON delay time (min)	3012	0BC4H	7012	1B64H	○	○	○	○	-	0 to 59
	ON delay time (s)	3013	0BC5H	7013	1B65H	○	○	○	○	-	
OFF delay time (h)	3014	0BC6H	7014	1B66H	○	○	○	○	-	0 to 99	
OFF delay time (min)	3015	0BC7H	7015	1B67H	○	○	○	○	-	0 to 59	
OFF delay time (s)	3016	0BC8H	7016	1B68H	○	○	○	○	-		
EV2	Type of action	3018	0BCAH	7018	1B6AH	○	○	○	○	-	0 to 28
	Target channel	3019	0BCBH	7019	1B6BH	○	○	○	○	-	1 to 4
	Alarm OR operation	3020	0BCCH	7020	1B6CH	○	○	○	○	-	0: OFF, 1: ON
	Event setting value (main)	3021	0BCDH	7021	1B6DH	○	○	○	○	-	-2000 to +10000 (Varies according to type selection.)
	Event setting value (sub)	3022	0BCEH	7022	1B6EH	○	○	○	○	-	
	Hysteresis	3023	0BCFH	7023	1B6FH	○	○	○	○	-	0 to 10000 (Varies according to type selection.)
	Direct/reverse	3024	0BD0H	7024	1B70H	○	○	○	○	-	0: Direct action 1: Reverse action
	Standby	3025	0BD1H	7025	1B71H	○	○	○	○	-	0: None, 1: Standby 2: Reset at SP change
	Event action in READY mode	3027	0BD4H	7027	1B74H	○	○	○	○	-	0: Continued, 1: Forcibly OFF
	ON delay time (h)	3028	0BD5H	7028	1B75H	○	○	○	○	-	0 to 99
	ON delay time (min)	3029	0BD6H	7029	1B76H	○	○	○	○	-	0 to 59
	ON delay time (s)	3030	0BD7H	7030	1B77H	○	○	○	○	-	
OFF delay time (h)	3031	0BD8H	7031	1B78H	○	○	○	○	-	0 to 99	
OFF delay time (min)	3032	0BD9H	7032	1B79H	○	○	○	○	-	0 to 59	
OFF delay time (s)	3033	0BDAH	7033	1B7AH	○	○	○	○	-		
EV3	Type of action	3035	0BDBH	7035	1B7BH	○	○	○	○	-	0 to 28
	Target channel	3036	0BDCH	7036	1B7CH	○	○	○	○	-	1 to 4
	Alarm OR operation	3037	0BDDH	7037	1B7DH	○	○	○	○	-	0: OFF, 1: ON
	Event setting value (main)	3038	0BDEH	7038	1B7EH	○	○	○	○	-	-2000 to +10000 (Varies according to type selection.)
	Event setting value (sub)	3039	0BDFH	7039	1B7FH	○	○	○	○	-	
	Hysteresis	3040	0BE0H	7040	1B80H	○	○	○	○	-	0 to 10000 (Varies according to type selection.)
	Direct/reverse	3041	0BE1H	7041	1B81H	○	○	○	○	-	0: Direct action 1: Reverse action
	Standby	3042	0BE2H	7042	1B82H	○	○	○	○	-	0: None, 1: Standby 2: Reset at SP change
	Event action in READY mode	3044	0BE4H	7044	1B84H	○	○	○	○	-	0: Continued, 1: Forcibly OFF
	ON delay time (h)	3045	0BE5H	7045	1B85H	○	○	○	○	-	0 to 99
	ON delay time (min)	3046	0BE6H	7046	1B86H	○	○	○	○	-	0 to 59
	ON delay time (s)	3047	0BE7H	7047	1B87H	○	○	○	○	-	
OFF delay time (h)	3048	0BE8H	7048	1B88H	○	○	○	○	-	0 to 99	
OFF delay time (min)	3049	0BE9H	7049	1B89H	○	○	○	○	-	0 to 59	
OFF delay time (s)	3050	0BEAH	7050	1B8AH	○	○	○	○	-		
EV4	Type of action	3052	0BECH	7052	1B8CH	○	○	○	○	-	0 to 28
	Target channel	3053	0BEDH	7053	1B8DH	○	○	○	○	-	1 to 4
	Alarm OR operation	3054	0BEEH	7054	1B8EH	○	○	○	○	-	0: OFF, 1: ON
	Event setting value (main)	3055	0BEFH	7055	1B8FH	○	○	○	○	-	-2000 to +10000 (Varies according to type selection.)
	Event setting value (sub)	3056	0BF0H	7056	1B90H	○	○	○	○	-	
	Hysteresis	3057	0BF1H	7057	1B91H	○	○	○	○	-	0 to 10000 (Varies according to type selection.)
	Direct/reverse	3058	0BF2H	7058	1B92H	○	○	○	○	-	0: Direct action 1: Reverse action
Standby	3059	0BF3H	7059	1B93H	○	○	○	○	-	0: None, 1: Standby 2: Reset at SP change	

Chapter 10. COMMUNICATIONS FUNCTIONS

Target Channel	Item	RAM address		ROM address		RAM		ROM		Decimal Point Information	Data Information
		Decimal	Hex	Decimal	Hex	R	W	R	W		
EV4	Event action in READY mode	3061	0BF5H	7061	1B95H	○	○	○	○	—	0: Continued, 1: Forcibly OFF
	ON delay time (h)	3062	0BF6H	7062	1B96H	○	○	○	○	—	0 to 99
	ON delay time (min)	3063	0BF7H	7063	1B97H	○	○	○	○	—	0 to 59
	ON delay time (s)	3064	0BF8H	7064	1B98H	○	○	○	○	—	
	OFF delay time (h)	3065	0BF9H	7065	1B99H	○	○	○	○	—	0 to 99
	OFF delay time (min)	3066	0BFAH	7066	1B9AH	○	○	○	○	—	0 to 59
	OFF delay time (s)	3067	0BFBH	7067	1B9BH	○	○	○	○	—	
EV bus 1	Type of action	3069	0BFDH	7069	1B9DH	○	○	○	○	—	0 to 28
	Target channel	3070	0BFEH	7070	1B9EH	○	○	○	○	—	1 to 4
	Alarm OR operation	3071	0BFFH	7071	1B9FH	○	○	○	○	—	0: OFF, 1: ON
	Event setting value (main)	3072	0C00H	7072	1BA0H	○	○	○	○	—	-2000 to +10000 (Varies according to type selection.)
	Event setting value (sub)	3073	0C01H	7073	1BA1H	○	○	○	○	—	
	Hysteresis	3074	0C02H	7074	1BA2H	○	○	○	○	—	0 to 10000 (Varies according to type selection.)
	Direct/reverse	3075	0C03H	7075	1BA3H	○	○	○	○	—	0: Direct action 1: Reverse action
	Standby	3076	0C04H	7076	1BA4H	○	○	○	○	—	0: None, 1: Standby 2: Reset at SP change
	Event action in READY mode	3078	0C06H	7078	1BA6H	○	○	○	○	—	0: Continued, 1: Forcibly OFF
	ON delay time (h)	3079	0C07H	7079	1BA7H	○	○	○	○	—	0 to 99
	ON delay time (min)	3080	0C08H	7080	1BA8H	○	○	○	○	—	0 to 59
	ON delay time (s)	3081	0C09H	7081	1BA9H	○	○	○	○	—	
	OFF delay time (h)	3082	0C0AH	7082	1BAAH	○	○	○	○	—	0 to 99
	OFF delay time (min)	3083	0C0BH	7083	1BABH	○	○	○	○	—	0 to 59
OFF delay time (s)	3084	0C0CH	7084	1BACH	○	○	○	○	—		
EV bus 2	Type of action	3086	0C0EH	7086	1BAEH	○	○	○	○	—	0 to 28
	Target channel	3087	0C0FH	7087	1BAFH	○	○	○	○	—	1 to 4
	Alarm OR operation	3088	0C00H	7088	1BA0H	○	○	○	○	—	0: OFF, 1: ON
	Event setting value (main)	3089	0C11H	7089	1BB1H	○	○	○	○	—	-2000 to +10000 (Varies according to type selection.)
	Event setting value (sub)	3090	0C12H	7090	1BB2H	○	○	○	○	—	
	Hysteresis	3091	0C13H	7091	1BB3H	○	○	○	○	—	0 to 10000 (Varies according to type selection.)
	Direct/reverse	3092	0C14H	7092	1BB4H	○	○	○	○	—	0: Direct action 1: Reverse action
	Standby	3093	0C15H	7093	1BB5H	○	○	○	○	—	0: None, 1: Standby 2: Reset at SP change
	Event action in READY mode	3095	0C17H	7095	1BB7H	○	○	○	○	—	0: Continued, 1: Forcibly OFF
	ON delay time (h)	3096	0C18H	7096	1BB8H	○	○	○	○	—	0 to 99
	ON delay time (min)	3097	0C19H	7097	1BB9H	○	○	○	○	—	0 to 59
	ON delay time (s)	3098	0C1AH	7098	1BBAH	○	○	○	○	—	
	OFF delay time (h)	3099	0C1BH	7099	1BBBH	○	○	○	○	—	0 to 99
	OFF delay time (min)	3100	0C1CH	7100	1BBCH	○	○	○	○	—	0 to 59
OFF delay time (s)	3101	0C1DH	7101	1BBDH	○	○	○	○	—		
EV bus 3	Type of action	3103	0C1FH	7103	1BBFH	○	○	○	○	—	0 to 28
	Target channel	3104	0C20H	7104	1BC0H	○	○	○	○	—	1 to 4
	Alarm OR operation	3105	0C21H	7105	1BC1H	○	○	○	○	—	0: OFF, 1: ON
	Event setting value (main)	3106	0C22H	7106	1BC2H	○	○	○	○	—	-2000 to +10000 (Varies according to type selection.)
	Event setting value (sub)	3107	0C23H	7107	1BC3H	○	○	○	○	—	
	Hysteresis	3108	0C24H	7108	1BC4H	○	○	○	○	—	0 to 10000 (Varies according to type selection.)
	Direct/reverse	3109	0C25H	7109	1BC5H	○	○	○	○	—	0: Direct action 1: Reverse action
	Standby	3110	0C26H	7110	1BC6H	○	○	○	○	—	0: None, 1: Standby 2: Reset at SP change
	Event action in READY mode	3112	0C28H	7112	1BC8H	○	○	○	○	—	0: Continued, 1: Forcibly OFF
	ON delay time (h)	3113	0C29H	7113	1BC9H	○	○	○	○	—	0 to 99
	ON delay time (min)	3114	0C2AH	7114	1BCAH	○	○	○	○	—	0 to 59
	ON delay time (s)	3115	0C2BH	7115	1BCBH	○	○	○	○	—	
	OFF delay time (h)	3116	0C2CH	7116	1BCCH	○	○	○	○	—	0 to 99
	OFF delay time (min)	3117	0C2DH	7117	1BCDH	○	○	○	○	—	0 to 59
OFF delay time (s)	3118	0C2EH	7118	1BCEH	○	○	○	○	—		

Target Channel	Item	RAM address		ROM address		RAM		ROM		Decimal Point Information	Data Information
		Decimal	Hex	Decimal	Hex	R	W	R	W		
EV bus 4	Type of action	3120	0C30H	7120	1BD0H	○	○	○	○	–	0 to 28
	Target channel	3121	0C31H	7121	1BD1H	○	○	○	○	–	1 to 4
	Alarm OR operation	3122	0C32H	7122	1BD2H	○	○	○	○	–	0: OFF, 1: ON
	Event setting value (main)	3123	0C33H	7123	1BD3H	○	○	○	○	–	–2000 to +10000 (Varies according to type selection.)
	Event setting value (sub)	3124	0C34H	7124	1BD4H	○	○	○	○	–	
	Hysteresis	3125	0C35H	7125	1BD5H	○	○	○	○	–	0 to 10000 (Varies according to type selection.)
	Direct/reverse	3126	0C36H	7126	1BD6H	○	○	○	○	–	0: Direct action 1: Reverse action
	Standby	3127	0C37H	7127	1BD7H	○	○	○	○	–	0: None, 1: Standby 2: Reset at SP change
	Event action in READY mode	3129	0C39H	7129	1BD9H	○	○	○	○	–	0: Continued, 1: Forcibly OFF
	ON delay time (h)	3130	0C3AH	7130	1BDAH	○	○	○	○	–	0 to 99
	ON delay time (min)	3131	0C3BH	7131	1BDBH	○	○	○	○	–	0 to 59
	ON delay time (s)	3132	0C3CH	7132	1BDDH	○	○	○	○	–	0 to 99
	OFF delay time (h)	3133	0C3DH	7133	1BDDH	○	○	○	○	–	0 to 99
	OFF delay time (min)	3134	0C3EH	7134	1BDEH	○	○	○	○	–	0 to 59
OFF delay time (s)	3135	0C3FH	7135	1BDFH	○	○	○	○	–		
CH1	Control method	3201	0C81H	7201	1C21H	○	○	○	○	–	0: ON/OFF
CH2		3202	0C82H	7202	1C22H	○	○	○	○	–	1: Self-tuning
CH3		3203	0C83H	7203	1C23H	○	○	○	○	–	2: Fixed PID
CH4		3204	0C84H	7204	1C24H	○	○	○	○	–	
CH1	Time proportional cycle	3207	0C87H	7207	1C27H	○	○	○	○	–	5 to 120 (relay)
CH2		3208	0C88H	7208	1C28H	○	○	○	○	–	1 to 120 (voltage)
CH3		3209	0C89H	7209	1C29H	○	○	○	○	–	
CH4		3210	0C8AH	7210	1C2AH	○	○	○	○	–	
CH1	PV bias	3211	0C8BH	7211	1C2BH	○	○	○	○	○	Varies according to decimal point information
CH2		3212	0C8CH	7212	1C2CH	○	○	○	○	○	
CH3		3213	0C8DH	7213	1C2DH	○	○	○	○	○	
CH4		3214	0C8EH	7214	1C2EH	○	○	○	○	○	
CH1	PV filter	3215	0C8FH	7215	1C2FH	○	○	○	○	Δ	0 to 1200 (10X value)
CH2		3216	0C90H	7216	1C30H	○	○	○	○	Δ	
CH3		3217	0C91H	7217	1C31H	○	○	○	○	Δ	
CH4		3218	0C92H	7218	1C32H	○	○	○	○	Δ	
–	Use of output branch control	3903	0F3FH	7903	1EDFH	○	○	○	○	–	0: OFF 1: ON
CH1	MV branch output channel	3219	0C93H	7219	1C33H	○	○	○	○	–	1 to 4
CH2		3220	0C94H	7220	1C34H	○	○	○	○	–	
CH3		3221	0C95H	7221	1C35H	○	○	○	○	–	
CH4		3222	0C96H	7222	1C36H	○	○	○	○	–	
CH1	Ratio for MV branch output	3223	0C97H	7223	1C37H	○	○	○	○	Δ1	0 to 10000 (1000X value)
CH2		3224	0C98H	7224	1C38H	○	○	○	○	Δ1	
CH3		3225	0C99H	7225	1C39H	○	○	○	○	Δ1	
CH4		3226	0C9AH	7226	1C3AH	○	○	○	○	Δ1	
CH1	MV rate-of-change limit	3227	0C9BH	7227	1C3BH	○	○	○	○	Δ	0 to 1000 (10X value)
CH2		3228	0C9CH	7228	1C3CH	○	○	○	○	Δ	
CH3		3229	0C9DH	7229	1C3DH	○	○	○	○	Δ	
CH4		3230	0C9EH	7230	1C3EH	○	○	○	○	Δ	
CT1	Designated channel for CT input	3231	0C9FH	7231	1C3FH	○	○	○	○	–	1 to 6
CT2		3232	0CA0H	7232	1C40H	○	○	○	○	–	
CH1	Current transformer input measurement standby time	3235	0CA3H	7235	1C43H	○	○	○	○	–	3 to 30
CH2		3236	0CA4H	7236	1C44H	○	○	○	○	–	
CH1	Time proportional operating mode	3239	0CA7H	7239	1C47H	○	○	○	○	–	0: Priority on controllability
CH2		3240	0CA8H	7240	1C48H	○	○	○	○	–	1: Priority on control device life
CH3		3241	0CA9H	7241	1C49H	○	○	○	○	–	
CH4		3242	0CAAH	7242	1C4AH	○	○	○	○	–	
CH1	Self-tuning up/down startup condition	3243	0CABH	7243	1C4BH	○	○	○	○	–	0: During PV up/down
CH2		3244	0CACH	7244	1C4CH	○	○	○	○	–	1: During PV up
CH3		3245	0CADH	7245	1C4DH	○	○	○	○	–	
CH4		3246	0CAEH	7246	1C4EH	○	○	○	○	–	
CH1	Self-tuning correction width	3247	0CAFH	7247	1C4FH	○	○	○	○	Δ	Thermocouple/RTD 0 to 20 DC voltage/current 0 to 50 (10X value)
CH2		3248	0CB0H	7248	1C50H	○	○	○	○	Δ	
CH3		3249	0CB1H	7249	1C51H	○	○	○	○	Δ	
CH4		3250	0CB2H	7250	1C52H	○	○	○	○	Δ	
CH1	Inter-channel deviation control	3255	0CB7H	7255	1C57H	○	○	○	○	–	0: OFF
CH2		3256	0CB8H	7256	1C58H	○	○	○	○	–	1: ON
CH3		3257	0CB9H	7257	1C59H	○	○	○	○	–	
CH4		3258	0CBAH	7258	1C5AH	○	○	○	○	–	

Chapter 10. COMMUNICATIONS FUNCTIONS

Target Channel	Item	RAM address		ROM address		RAM		ROM		Decimal Point Information	Data Information
		Decimal	Hex	Decimal	Hex	R	W	R	W		
CH1	Designated channel for inter-channel deviation control	3259	0CBBH	7259	1C5BH	○	○	○	○	–	1 to 4
CH2		3260	0CBCH	7260	1C5CH	○	○	○	○	–	
CH3		3261	0CBDH	7261	1C5DH	○	○	○	○	–	
CH4		3262	0CBEH	7262	1C5EH	○	○	○	○	–	
CH1	Inter-channel deviation control type	3263	0CBFH	7263	1C5FH	○	○	○	○	–	0: PV + deviation value 1: SP + deviation value
CH2		3264	0CC0H	7264	1C60H	○	○	○	○	–	
CH3		3265	0CC1H	7265	1C61H	○	○	○	○	–	
CH4		3266	0CC2H	7266	1C62H	○	○	○	○	–	
CH1	Inter-channel deviation control deviation value	3267	0CC3H	7267	1C63H	○	○	○	○	○	–2000 to +10000 (Varies according to decimal point information)
CH2		3268	0CC4H	7268	1C64H	○	○	○	○	○	
CH3		3269	0CC5H	7269	1C65H	○	○	○	○	○	
CH4		3270	0CC6H	7270	1C66H	○	○	○	○	○	
CH1	MV branch output offset	3271	0CC7H	7271	1C67H	○	○	○	○	Δ	–2000 to +10000 (10X value)
CH2		3272	0CC8H	7272	1C68H	○	○	○	○	Δ	
CH3		3273	0CC9H	7273	1C69H	○	○	○	○	Δ	
CH4		3274	0CCA	7274	1C6AH	○	○	○	○	Δ	
–	Position proportional control type	3275	0CCBH	7275	1C6BH	○	○	○	○	–	For details, see page 9-6.
CH1	Dead zone	3276	0CCCH	7276	1C6CH	○	○	○	○	–	1 to 250 (10X value)
CH2		3277	0CCDH	7277	1C6DH	○	○	○	○	–	
CH1	Motor adjustment	3278	0CCEH	7278	1C6EH	○	○	○	○	–	0: Stop 1: Startup
CH2		3279	0CCFH	7279	1C6FH	○	○	○	○	–	
CH1	Adjustment value on the fully closed side	3280	0CD0H	7280	1C70H	○	○	○	○	–	0 to 9999
CH2		3281	0CD1H	7281	1C71H	○	○	○	○	–	
CH1	Adjustment value on the full open side	3282	0CD2H	7282	1C72H	○	○	○	○	–	0 to 9999
CH2		3283	0CD3H	7283	1C73H	○	○	○	○	–	
CH1	Motor open time	3284	0CD4H	7284	1C74H	○	○	○	○	–	0 to 250
CH2		3285	0CD5H	7285	1C75H	○	○	○	○	–	
CH1	Motor resistance selection	3286	0CD6H	7286	1C76H	○	○	○	○	–	For details, see page 9-6.
CH2		3287	0CD7H	7287	1C77H	○	○	○	○	–	
CH1	Potentiometer long service life	3288	0CD8H	7288	1C78H	○	○	○	○	–	For details, see page 9-6.
CH2		3289	0CD9H	7289	1C79H	○	○	○	○	–	
CH1	External bus type definitions	3292	0CDCH	7292	1C7CH	○	○	○	○	–	0 to 1 For details, see page 8-30.
–	Energy saving	3293	0CDDH	7293	1C7DH	○	○	○	○	–	For details, see page 9-12.
–	Energy saving delay	3294	0CDEH	7294	1C7EH	○	○	○	○	–	
CH1	Control method	3301	0CE5H	7301	1C85H	○	○	○	○	–	RAM address: Alias of 3201W
	Time proportional cycle	3302	0CE6H	7302	1C86H	○	○	○	○	–	RAM address: Alias of 3207W
	PV bias	3303	0CE7H	7303	1C87H	○	○	○	○	○	RAM address: Alias of 3211W
	PV filter	3304	0CE8H	7304	1C88H	○	○	○	○	Δ	RAM address: Alias of 3215W
	Self-tuning up/down startup condition	3305	0CE9H	7305	1C89H	○	○	○	○	–	RAM address: Alias of 3243W
	Self-tuning correction width	3306	0CEAH	7306	1C8AH	○	○	○	○	Δ	RAM address: Alias of 3247W
	MV branch output channel	3307	0CEBH	7307	1C8BH	○	○	○	○	–	RAM address: Alias of 3903W
	Ratio for MV branch output	3308	0CECH	7308	1C8CH	○	○	○	○	Δ1	RAM address: Alias of 3223W
	MV rate-of-change limit	3309	0CEDH	7309	1C8DH	○	○	○	○	Δ	RAM address: Alias of 3227W
	CT measurement standby time	3311	0CEFH	7311	1C8FH	○	○	○	○	–	RAM address: Alias of 3235W
	Time proportional operating mode	3312	0CF0H	7312	1C90H	○	○	○	○	–	RAM address: Alias of 3239W
CH2	Control method	3313	0CF1H	7313	1C91H	○	○	○	○	–	RAM address: Alias of 3202W
	Time proportional cycle	3314	0CF2H	7314	1C92H	○	○	○	○	–	RAM address: Alias of 3208W
	PV bias	3315	0CF3H	7315	1C93H	○	○	○	○	○	RAM address: Alias of 3212W
	PV filter	3316	0CF4H	7316	1C94H	○	○	○	○	Δ	RAM address: Alias of 3216W
	Self-tuning up/down startup condition	3317	0CF5H	7317	1C95H	○	○	○	○	–	RAM address: Alias of 3244W
	Self-tuning correction width	3318	0CF6H	7318	1C96H	○	○	○	○	Δ	RAM address: Alias of 3248W
	MV branch output channel	3319	0CF7H	7319	1C97H	○	○	○	○	–	RAM address: Alias of 3904W
	Ratio for MV branch output	3320	0CF8H	7320	1C98H	○	○	○	○	Δ1	RAM address: Alias of 3224W
	MV rate-of-change limit	3321	0CF9H	7321	1C99H	○	○	○	○	Δ	RAM address: Alias of 3228W
	CT measurement standby time	3323	0CFBH	7323	1C9BH	○	○	○	○	–	RAM address: Alias of 3236W
	Time proportional operating mode	3324	0CFCH	7324	1C9CH	○	○	○	○	–	RAM address: Alias of 3240W
CH3	Control method	3325	0CFDH	7325	1C9DH	○	○	○	○	–	RAM address: Alias of 3203W
	Time proportional cycle	3326	0CFEH	7326	1C9EH	○	○	○	○	–	RAM address: Alias of 3209W
	PV bias	3327	0CFFH	7327	1C9FH	○	○	○	○	○	RAM address: Alias of 3213W
	PV filter	3328	0D00H	7328	1CA0H	○	○	○	○	Δ	RAM address: Alias of 3217W
	Self-tuning up/down startup condition	3329	0D01H	7329	1CA1H	○	○	○	○	–	RAM address: Alias of 3245W

Target Channel	Item	RAM address		ROM address		RAM		ROM		Decimal Point Information	Data Information
		Decimal	Hex	Decimal	Hex	R	W	R	W		
CH3	Self-tuning correction width	3330	0D02H	7330	1CA2H	○	○	○	○	Δ	RAM address: Alias of 3249W
	MV branch output channel	3331	0D03H	7331	1CA3H	○	○	○	○	–	RAM address: Alias of 3905W
	Ratio for MV branch output	3332	0D04H	7332	1CA4H	○	○	○	○	Δ1	RAM address: Alias of 3225W
	MV rate-of-change limit	3333	0D05H	7333	1CA5H	○	○	○	○	Δ	RAM address: Alias of 3229W
	Time proportional operating mode	3336	0D08H	7336	1CA8H	○	○	○	○	–	RAM address: Alias of 3241W
CH4	Control method	3337	0D09H	7337	1CA9H	○	○	○	○	–	RAM address: Alias of 3204W
	Time proportional cycle	3338	0D0AH	7338	1CAAH	○	○	○	○	–	RAM address: Alias of 3210W
	PV bias	3339	0D0BH	7339	1CABH	○	○	○	○	○	RAM address: Alias of 3214W
	PV filter	3340	0D0CH	7340	1CACH	○	○	○	○	Δ	RAM address: Alias of 3218W
	Self-tuning up/down startup condition	3341	0D0DH	7341	1CADH	○	○	○	○	–	RAM address: Alias of 3246W
	Self-tuning correction width	3342	0D0EH	7342	1CAEH	○	○	○	○	Δ	RAM address: Alias of 3250W
	MV branch output channel	3343	0D0FH	7343	1CAFH	○	○	○	○	–	RAM address: Alias of 3906W
	Ratio for MV branch output	3344	0D10H	7344	1CB0H	○	○	○	○	Δ1	RAM address: Alias of 3226W
	MV rate-of-change limit	3345	0D11H	7345	1CB1H	○	○	○	○	Δ	RAM address: Alias of 3230W
	Time proportional operating mode	3348	0D14H	7348	1CB4H	○	○	○	○	–	RAM address: Alias of 3242W
–	Memory protection	3401	0D49H	7401	1CE9H	○	○	○	○	–	0 to 3
–	Single/multi-SP set	3402	0D4AH	7402	1CEAH	○	○	○	○	–	0: Single SP 1: Multi-SP
CH1	Temperature unit	3403	0D4BH	7403	1CEBH	○	○	○	○	–	0: °C, 1: Special unit
	Control action	3404	0D4CH	7404	1CECH	○	○	○	○	–	0: Heat control 1: Cooling control
	Input type	3405	0D4DH	7405	1CEDH	○	○	○	○	–	0 to 13, 21 to 28, 41 to 44
	Decimal point position	3406	0D4EH	7406	1CEEH	○	□	○	□	–	0, 1 (Varies according to range type.)
	PV range lower limit	3407	0D4FH	7407	1CEFH	○	○	○	○	○	Varies according to range type and decimal point information.
	PV range upper limit	3408	0D50H	7408	1CF0H	○	○	○	○	○	
	Lower SP limit	3409	0D51H	7409	1CF1H	○	○	○	○	○	
	Upper SP limit	3410	0D52H	7410	1CF2H	○	○	○	○	○	
	MV at PV alarm occurrence	3411	0D53H	7411	1CF3H	○	○	○	○	Δ	–100 to +1100 (10X value)
	MV in READY mode	3412	0D54H	7412	1CF4H	○	○	○	○	Δ	
	PID initial MV	3413	0D55H	7413	1CF5H	○	○	○	○	Δ	
	Cold junction compensation action	3414	0D56H	7414	1CF6H	○	○	○	○	–	0: ON 1: OFF
	AUTO/MANUAL switching action	3415	0D57H	7415	1CF7H	○	○	○	○	–	0: Bumpless 1: Preset
	Preset manual value	3416	0D58H	7416	1CF8H	○	○	○	○	Δ	–100 to +1100 (10X value)
	SP down gradient	3417	0D59H	7417	1CF9H	○	○	○	○	○	Varies according to decimal point information
	SP up gradient	3418	0D5AH	7418	1CFAH	○	○	○	○	○	
SP gradient time unit	3419	0D5BH	7419	1CFBH	○	○	○	○	○	0: unit/min 1: unit/h	
CH2	Temperature unit	3421	0D5DH	7421	1CFDH	○	○	○	○	–	0: °C, 1: Special unit
	Control action	3422	0D5EH	7422	1CFEH	○	○	○	○	–	0: Heat control 1: Cooling control
	Input type	3423	0D5FH	7423	1CFFH	○	○	○	○	–	0 to 13, 21 to 28, 41 to 44
	Decimal point position	3424	0D60H	7424	1D00H	○	○	○	○	–	0, 1 (Varies according to range type.)
	PV range lower limit	3425	0D61H	7425	1D01H	○	○	○	○	○	Varies according to range type and decimal point information.
	PV range upper limit	3426	0D62H	7426	1D02H	○	○	○	○	○	
	Lower SP limit	3427	0D63H	7427	1D03H	○	○	○	○	○	
	Upper SP limit	3428	0D64H	7428	1D04H	○	○	○	○	○	
	MV at PV alarm occurrence	3429	0D65H	7429	1D05H	○	○	○	○	Δ	–100 to +1100 (10X value)
	MV in READY mode	3430	0D66H	7430	1D06H	○	○	○	○	Δ	
	PID initial MV	3431	0D67H	7431	1D07H	○	○	○	○	Δ	
	Cold junction compensation action	3432	0D68H	7432	1D08H	○	○	○	○	–	0: ON 1: OFF
	AUTO/MANUAL switching action	3433	0D69H	7433	1D09H	○	○	○	○	–	0: Bumpless 1: Preset
	Preset manual value	3434	0D6AH	7434	1D0AH	○	○	○	○	Δ	–100 to +1100 (10X value)
SP down gradient	3435	0D6BH	7435	1D0BH	○	○	○	○	○	Varies according to decimal point information	
SP up gradient	3436	0D6CH	7436	1D0CH	○	○	○	○	○		
SP gradient time unit	3437	0D6DH	7437	1D0DH	○	○	○	○	○	0: unit/min 1: unit/h	
CH3	Temperature unit	3439	0D6FH	7439	1D0FH	○	○	○	○	–	0: °C, 1: Special unit
	Control action	3440	0D70H	7440	1D10H	○	○	○	○	–	0: Heat control 1: Cooling control
	Input type	3441	0D71H	7441	1D11H	○	○	○	○	–	0 to 13, 21 to 28, 41 to 44
	Decimal point position	3442	0D72H	7442	1D12H	○	○	○	○	–	0, 1 (Varies according to range type.)
	PV range lower limit	3443	0D73H	7443	1D13H	○	○	○	○	○	Varies according to range type and decimal point information.
	PV range upper limit	3444	0D74H	7444	1D14H	○	○	○	○	○	
	Lower SP limit	3445	0D75H	7445	1D15H	○	○	○	○	○	
	Upper SP limit	3446	0D76H	7446	1D16H	○	○	○	○	○	

Chapter 10. COMMUNICATIONS FUNCTIONS

Target Channel	Item	RAM address		ROM address		RAM		ROM		Decimal Point Information	Data Information
		Decimal	Hex	Decimal	Hex	R	W	R	W		
CH3	MV at PV alarm occurrence	3447	0D77H	7447	1D17H	○	○	○	○	Δ	-100 to +1100 (10X value)
	MV in READY mode	3448	0D78H	7448	1D18H	○	○	○	○	Δ	
	PID initial MV	3449	0D79H	7449	1D19H	○	○	○	○	Δ	
	Cold junction compensation action	3450	0D7AH	7450	1D1AH	○	○	○	○	-	0: ON 1: OFF
	AUTO/MANUAL switching action	3451	0D7BH	7451	1D1BH	○	○	○	○	-	0: Bumpless 1: Preset
	Preset manual value	3452	0D7CH	7452	1D1CH	○	○	○	○	Δ	-100 to +1100 (10X value)
	SP down gradient	3453	0D7DH	7453	1D1DH	○	○	○	○	○	Varies according to decimal point information
	SP up gradient	3454	0D7EH	7454	1D1EH	○	○	○	○	○	
SP gradient time unit	3455	0D7FH	7455	1D1FH	○	○	○	○	○	0: unit/min 1: unit/h	
CH4	Temperature unit	3457	0D81H	7457	1D21H	○	○	○	○	-	0: °C, 1: Special unit
	Control action	3458	0D82H	7458	1D22H	○	○	○	○	-	0: Heat control 1: Cooling control
	Input type	3459	0D83H	7459	1D23H	○	○	○	○	-	0 to 13, 21 to 28, 41 to 44
	Decimal point position	3460	0D84H	7460	1D24H	○	○	○	○	-	0, 1 (Varies according to range type.)
	PV range lower limit	3461	0D85H	7461	1D25H	○	○	○	○	○	Varies according to range type and decimal point information.
	PV range upper limit	3462	0D86H	7462	1D26H	○	○	○	○	○	
	Lower SP limit	3463	0D87H	7463	1D27H	○	○	○	○	○	
	Upper SP limit	3464	0D88H	7464	1D28H	○	○	○	○	○	
	MV at PV alarm occurrence	3465	0D89H	7465	1D29H	○	○	○	○	Δ	-100 to +1100 (10X value)
	MV in READY mode	3466	0D8AH	7466	1D2AH	○	○	○	○	Δ	
	PID initial MV	3467	0D8BH	7467	1D2BH	○	○	○	○	Δ	
	Cold junction compensation action	3468	0D8CH	7468	1D2CH	○	○	○	○	-	0: ON 1: OFF
	AUTO/MANUAL switching action	3469	0D8DH	7469	1D2DH	○	○	○	○	-	0: Bumpless 1: Preset
	Preset manual value	3470	0D8EH	7470	1D2EH	○	○	○	○	Δ	-100 to +1100 (10X value)
	SP down gradient	3471	0D8FH	7471	1D2FH	○	○	○	○	○	Varies according to decimal point information
	SP up gradient	3472	0D90H	7472	1D30H	○	○	○	○	○	
SP gradient time unit	3473	0D91H	7473	1D31H	○	○	○	○	○	0: unit/min 1: unit/h	
-	LED operation type	3501	0DADH	7501	1D4DH	○	○	○	○	-	0 to 18
-	Channel targeted for LED operation	3502	0DAEH	7502	1D4EH	○	○	○	○	-	0 to 4
AUX1	Type of action	3503	0DAFH	7503	1D4FH	○	○	○	○	-	0 to 5
	Target channel	3504	0DB0H	7504	1D50H	○	○	○	○	-	1 to 4
	0% setting	3505	0DB1H	7505	1D51H	○	○	○	○	-	-2000 to +10000 (Varies according to type selection.)
	100% setting	3506	0DB2H	7506	1D52H	○	○	○	○	-	
Output type	3507	0DB3H	7507	1D53H	○	○	○	○	-	0: 4 to 20mA 1: 0 to 20mA	
AUX2	Type of action	3508	0DB4H	7508	1D54H	○	○	○	○	-	0 to 5
	Target channel	3509	0DB5H	7509	1D55H	○	○	○	○	-	1 to 4
	0% setting	3510	0DB6H	7510	1D56H	○	○	○	○	-	-2000 to +10000 (Varies according to type selection.)
	100% setting	3511	0DB7H	7511	1D57H	○	○	○	○	-	
Output type	3512	0DB8H	7512	1D58H	○	○	○	○	-	0: 4 to 20mA 1: 0 to 20mA	
-	Operation of heat/cool control	3513	0DB9H	7513	1D59H	○	○	○	○	-	0: OFF 1: ON
CH1	Heat/cool control dead zone	3514	0DBAH	7514	1D5AH	○	○	○	○	Δ	-1000 to +1000 (10X value)
CH2		3517	0DBDH	7517	1D5DH	○	○	○	○	Δ	
-	Remote SP input	3519	0DBFH	7519	1D5FH	○	○	○	○	-	0: OFF 1: ON
RSW1	Type of action	3601	0E11H	7601	1DB1H	○	○	○	○	-	0 to 14
	Target channel	3602	0E12H	7602	1DB2H	○	○	○	○	-	0 to 8 (Varies according to type selection.)
	Input assignment 2	3603	0E13H	7603	1DB3H	○	○	○	○	-	For details, see Table 10-12.
	Input assignment 1	3604	0E14H	7604	1DB4H	○	○	○	○	-	For details, see Table 10-11.
	Logic	3605	0E15H	7605	1DB5H	○	○	○	○	-	0: OR 1: AND
	Direct/reverse	3606	0E16H	7606	1DB6H	○	○	○	○	-	0: Direct action 1: Reverse action
RSW2	Type of action	3607	0E17H	7607	1DB7H	○	○	○	○	-	0 to 14
	Target channel	3608	0E18H	7608	1DB8H	○	○	○	○	-	0 to 2
	Input assignment 2	3609	0E19H	7609	1DB9H	○	○	○	○	-	For details, see Table 10-12.
	Input assignment 1	3610	0E1AH	7610	1DBAH	○	○	○	○	-	For details, see Table 10-11.
	Logic	3611	0E1BH	7611	1DBBH	○	○	○	○	-	0: OR 1: AND
	Direct/reverse	3612	0E1CH	7612	1DBCH	○	○	○	○	-	0: Direct action 1: Reverse action

Target Channel	Item	RAM address		ROM address		RAM		ROM		Decimal Point Information	Data Information
		Decimal	Hex	Decimal	Hex	R	W	R	W		
RSW3	Type of action	3613	0E1DH	7613	1DBDH	○	○	○	○	–	0 to 14
	Target channel	3614	0E1EH	7614	1DBEH	○	○	○	○	–	0 to 2
	Input assignment 2	3615	0E1FH	7615	1DBFH	○	○	○	○	–	For details, see Table 10-12.
	Input assignment 1	3616	0E20H	7616	1DC0H	○	○	○	○	–	For details, see Table 10-11.
	Logic	3617	0E21H	7617	1DC1H	○	○	○	○	–	0: OR 1: AND
	Direct/reverse	3618	0E22H	7618	1DC2H	○	○	○	○	–	0: Direct action 1: Reverse action
RSW4	Type of action	3619	0E23H	7619	1DC3H	○	○	○	○	–	0 to 14
	Target channel	3620	0E24H	7620	1DC4H	○	○	○	○	–	0 to 2
	Input assignment 2	3621	0E25H	7621	1DC5H	○	○	○	○	–	For details, see Table 10-12.
	Input assignment 1	3622	0E26H	7622	1DC6H	○	○	○	○	–	For details, see Table 10-11.
	Logic	3623	0E27H	7623	1DC7H	○	○	○	○	–	0: OR 1: AND
	Direct/reverse	3624	0E28H	7624	1DC8H	○	○	○	○	–	0: Direct action 1: Reverse action
RSW bus 1	Type of action	3625	0E29H	7625	1DC9H	○	○	○	○	–	0 to 14
	Target channel	3626	0E2AH	7626	1DCAH	○	○	○	○	–	0 to 2
	Input assignment 2	3627	0E2BH	7627	1DCBH	○	○	○	○	–	For details, see Table 10-12.
	Input assignment 1	3628	0E2CH	7628	1DCCH	○	○	○	○	–	For details, see Table 10-11.
	Logic	3629	0E2DH	7629	1DCDH	○	○	○	○	–	0: OR 1: AND
	Direct/reverse	3630	0E2EH	7630	1DCEH	○	○	○	○	–	0: Direct action 1: Reverse action
RSW bus 2	Type of action	3631	0E2FH	7631	1DCFH	○	○	○	○	–	0 to 14
	Target channel	3632	0E30H	7632	1DD0H	○	○	○	○	–	0 to 2
	Input assignment 2	3633	0E31H	7633	1DD1H	○	○	○	○	–	For details, see Table 10-12.
	Input assignment 1	3634	0E32H	7634	1DD2H	○	○	○	○	–	For details, see Table 10-11.
	Logic	3635	0E33H	7635	1DD3H	○	○	○	○	–	0: OR 1: AND
	Direct/reverse	3636	0E34H	7636	1DD4H	○	○	○	○	–	0: Direct action 1: Reverse action
RSW bus 3	Type of action	3637	0E35H	7637	1DD5H	○	○	○	○	–	0 to 14
	Target channel	3638	0E36H	7638	1DD6H	○	○	○	○	–	0 to 2
	Input assignment 2	3639	0E37H	7639	1DD7H	○	○	○	○	–	For details, see Table 10-12.
	Input assignment 1	3640	0E38H	7640	1DD8H	○	○	○	○	–	For details, see Table 10-11.
	Logic	3641	0E39H	7641	1DD9H	○	○	○	○	–	0: OR 1: AND
	Direct/reverse	3642	0E3AH	7642	1DDAH	○	○	○	○	–	0: Direct action 1: Reverse action
RSW bus 4	Type of action	3643	0E3BH	7643	1DDBH	○	○	○	○	–	0 to 14
	Target channel	3644	0E3CH	7644	1DDCH	○	○	○	○	–	0 to 2
	Input assignment 2	3645	0E3DH	7645	1DDDH	○	○	○	○	–	For details, see Table 10-12.
	Input assignment 1	3646	0E3EH	7646	1DDEH	○	○	○	○	–	For details, see Table 10-11.
	Logic	3647	0E3FH	7647	1DDFH	○	○	○	○	–	0: OR 1: AND
	Direct/reverse	3648	0E40H	7648	1DE0H	○	○	○	○	–	0: Direct action 1: Reverse action
RSW1	Input assignment 3	3649	0E41H	7649	1DE1H	○	○	○	○	–	For details, see Table 10-13.
RSW2		3650	0E42H	7650	1DE2H	○	○	○	○	–	
RSW3		3651	0E43H	7651	1DE3H	○	○	○	○	–	
RSW4		3652	0E44H	7652	1DE4H	○	○	○	○	–	
RSW bus1		3653	0E45H	7653	1DE5H	○	○	○	○	–	
RSW bus2	3654	0E46H	7654	1DE6H	○	○	○	○	–		
RSW bus3	3655	0E47H	7655	1DE7H	○	○	○	○	–		
RSW bus4	3656	0E48H	7656	1DE8H	○	○	○	○	–		
EV1	Output assignment 2	3701	0E75H	7701	1E15H	○	○	○	○	–	For details, see Table 10-9.
	Output assignment 1	3702	0E76H	7702	1E16H	○	○	○	○	–	For details, see Table 10-8.
	Logic	3703	0E77H	7703	1E17H	○	○	○	○	–	0: OR 1: AND
	Latch	3704	0E78H	7704	1E18H	○	○	○	○	–	0: OFF 1: ON(latch in ON) 2: ON(latch in OFF)
	Direct/reverse	3705	0E79H	7705	1E19H	○	○	○	○	–	0: Direct action 1: Reverse action
EV2	Output assignment 2	3706	0E7AH	7706	1E1AH	○	○	○	○	–	For details, see Table 10-9.
	Output assignment 1	3707	0E7BH	7707	1E1BH	○	○	○	○	–	For details, see Table 10-8.
	Logic	3708	0E7CH	7708	1E1CH	○	○	○	○	–	0: OR 1: AND
	Latch	3709	0E7DH	7709	1E1DH	○	○	○	○	–	0: OFF 1: ON(latch in ON) 2: ON(latch in OFF)
	Direct/reverse	3710	0E7EH	7710	1E1EH	○	○	○	○	–	0: Direct action 1: Reverse action

Chapter 10. COMMUNICATIONS FUNCTIONS

Target Channel	Item	RAM address		ROM address		RAM		ROM		Decimal Point Information	Data Information
		Decimal	Hex	Decimal	Hex	R	W	R	W		
EV3	Output assignment 2	3711	0E7FH	7711	1E1FH	○	○	○	○	–	For details, see Table 10-9 .
	Output assignment 1	3712	0E80H	7712	1E20H	○	○	○	○	–	For details, see Table 10-8 .
	Logic	3713	0E81H	7713	1E21H	○	○	○	○	–	0: OR 1: AND
	Latch	3714	0E82H	7714	1E22H	○	○	○	○	–	0: OFF 1: ON(latch in ON) 2: ON(latch in OFF)
	Direct/reverse	3715	0E83H	7715	1E23H	○	○	○	○	–	0: Direct action 1: Reverse action
EV4	Output assignment 2	3716	0E84H	7716	1E24H	○	○	○	○	–	For details, see Table 10-9 .
	Output assignment 1	3717	0E85H	7717	1E25H	○	○	○	○	–	For details, see Table 10-8 .
	Logic	3718	0E86H	7718	1E26H	○	○	○	○	–	0: OR 1: AND
	Latch	3719	0E87H	7719	1E27H	○	○	○	○	–	0: OFF 1: ON(latch in ON) 2: ON(latch in OFF)
	Direct/reverse	3720	0E88H	7720	1E28H	○	○	○	○	–	0: Direct action 1: Reverse action
EV bus 1	Output assignment 2	3721	0E89H	7721	1E29H	○	○	○	○	–	For details, see Table 10-9 .
	Output assignment 1	3722	0E8AH	7722	1E2AH	○	○	○	○	–	For details, see Table 10-8 .
	Logic	3723	0E8BH	7723	1E2BH	○	○	○	○	–	0: OR 1: AND
	Latch	3724	0E8CH	7724	1E2CH	○	○	○	○	–	0: OFF 1: ON(latch in ON) 2: ON(latch in OFF)
	Direct/reverse	3725	0E8DH	7725	1E2DH	○	○	○	○	–	0: Direct action 1: Reverse action
EV bus 2	Output assignment 2	3726	0E8EH	7726	1E2EH	○	○	○	○	–	For details, see Table 10-9 .
	Output assignment 1	3727	0E8FH	7727	1E2FH	○	○	○	○	–	For details, see Table 10-8 .
	Logic	3728	0E90H	7728	1E30H	○	○	○	○	–	0: OR 1: AND
	Latch	3729	0E91H	7729	1E31H	○	○	○	○	–	0: OFF 1: ON(latch in ON) 2: ON(latch in OFF)
	Direct/reverse	3730	0E92H	7730	1E32H	○	○	○	○	–	0: Direct action 1: Reverse action
EV bus 3	Output assignment 2	3731	0E93H	7731	1E33H	○	○	○	○	–	For details, see Table 10-9 .
	Output assignment 1	3732	0E94H	7732	1E34H	○	○	○	○	–	For details, see Table 10-8 .
	Logic	3733	0E95H	7733	1E35H	○	○	○	○	–	0: OR 1: AND
	Latch	3734	0E96H	7734	1E36H	○	○	○	○	–	0: OFF 1: ON(latch in ON) 2: ON(latch in OFF)
	Direct/reverse	3735	0E97H	7735	1E37H	○	○	○	○	–	0: Direct action 1: Reverse action
EV bus 4	Output assignment 2	3736	0E98H	7736	1E38H	○	○	○	○	–	For details, see Table 10-9 .
	Output assignment 1	3737	0E99H	7737	1E39H	○	○	○	○	–	For details, see Table 10-8 .
	Logic	3738	0E9AH	7738	1E3AH	○	○	○	○	–	0: OR 1: AND
	Latch	3739	0E9BH	7739	1E3BH	○	○	○	○	–	0: OFF 1: ON(latch in ON) 2: ON(latch in OFF)
	Direct/reverse	3740	0E9CH	7740	1E3CH	○	○	○	○	–	0: Direct action 1: Reverse action
OUT1	Output assignment 2	3741	0E9DH	7741	1E3DH	○	○	○	○	–	For details, see Table 10-9 .
	Output assignment 1	3742	0E9EH	7742	1E3EH	○	○	○	○	–	For details, see Table 10-8 .
	Logic	3743	0E9FH	7743	1E3FH	○	○	○	○	–	0: OR 1: AND
	Latch	3744	0EA0H	7744	1E40H	○	○	○	○	–	0: OFF 1: ON(latch in ON) 2: ON(latch in OFF)
	Direct/reverse	3745	0EA1H	7745	1E41H	○	○	○	○	–	0: Direct action 1: Reverse action
OUT2	Output assignment 2	3746	0EA2H	7746	1E42H	○	○	○	○	–	For details, see Table 10-9 .
	Output assignment 1	3747	0EA3H	7747	1E43H	○	○	○	○	–	For details, see Table 10-8 .
	Logic	3748	0EA4H	7748	1E44H	○	○	○	○	–	0: OR 1: AND
	Latch	3749	0EA5H	7749	1E45H	○	○	○	○	–	0: OFF 1: ON(latch in ON) 2: ON(latch in OFF)
	Direct/reverse	3750	0EA6H	7750	1E46H	○	○	○	○	–	0: Direct action 1: Reverse action

Target Channel	Item	RAM address		ROM address		RAM		ROM		Decimal Point Information	Data Information
		Decimal	Hex	Decimal	Hex	R	W	R	W		
OUT3	Output assignment 2	3751	0EA7H	7751	1E47H	○	○	○	○	–	For details, see Table 10-9 .
	Output assignment 1	3752	0EA8H	7752	1E48H	○	○	○	○	–	For details, see Table 10-8 .
	Logic	3753	0EA9H	7753	1E49H	○	○	○	○	–	0: OR 1: AND
	Latch	3754	0EAAH	7754	1E4AH	○	○	○	○	–	0: OFF 1: ON(latch in ON) 2: ON(latch in OFF)
	Direct/reverse	3755	0EABH	7755	1E4BH	○	○	○	○	–	0: Direct action 1: Reverse action
OUT4	Output assignment 2	3756	0EACH	7756	1E4CH	○	○	○	○	–	For details, see Table 10-9 .
	Output assignment 1	3757	0EADH	7757	1E4DH	○	○	○	○	–	For details, see Table 10-8 .
	Logic	3758	0EAEH	7758	1E4EH	○	○	○	○	–	0: OR 1: AND
	Latch	3759	0EAFH	7759	1E4FH	○	○	○	○	–	0: OFF 1: ON(latch in ON) 2: ON(latch in OFF)
	Direct/reverse	3760	0EB0H	7760	1E50H	○	○	○	○	–	0: Direct action 1: Reverse action
EV1	Output assignment 3	3761	0EB1H	7761	1E51H	○	○	○	○	–	For details, see Table 10-10 .
EV2		3762	0EB2H	7762	1E52H	○	○	○	○	–	
EV3		3763	0EB3H	7763	1E53H	○	○	○	○	–	
EV4		3764	0EB4H	7764	1E54H	○	○	○	○	–	
EV bus 1	Output assignment 3	3765	0EB5H	7765	1E55H	○	○	○	○	–	For details, see Table 10-10 .
EV bus 2		3766	0EB6H	7766	1E56H	○	○	○	○	–	
EV bus 3		3767	0EB7H	7767	1E57H	○	○	○	○	–	
EV bus 4		3768	0EB8H	7768	1E58H	○	○	○	○	–	
OUT1	Output assignment 3	3769	0EB9H	7769	1E59H	○	○	○	○	–	For details, see Table 10-10 .
OUT2		3770	0EBAH	7770	1E5AH	○	○	○	○	–	
OUT3		3771	0EBBH	7771	1E5BH	○	○	○	○	–	
OUT4		3772	0EBCH	7772	1E5CH	○	○	○	○	–	
–	Data format	3802	0EDAH	7802	1E7AH	○	×	○	×	–	0: 8bit EVEN 1st 1: 8bit NO 2st
–	Transmission speed	3803	0EDBH	7803	1E7BH	○	×	○	×	–	0: 2400 1: 4800 2: 9600 3: 19200
–	Min. communications response time	3804	0EDCH	7804	1E7CH	○	○	○	○	–	0: 1ms, 2: 10ms 3: 100ms 4: 200ms
–	Min. communications response time (addition)	3805	0EDDH	7805	1E7DH	○	○	○	○	–	0 to 100ms
–	Communications type	3806	0EDEH	7806	1E7EH	○	○	○	○	–	For details, see page 10-1 .

■ Bit Information Data

● Table 10-1: Representative all alarms

2 ¹⁵	2 ¹⁴	2 ¹³	2 ¹²	2 ¹¹	2 ¹⁰	2 ⁹	2 ⁸	2 ⁷	2 ⁶	2 ⁵	2 ⁴	2 ³	2 ²	2 ¹	2 ⁰
16	15	14	13	12	11	10	9	8	7	6	5	4	3	2	1

Item	Value	Remarks
1 PV error representative	The value becomes "1" if an error occurs on even one of PV1 to PV4.	PV upper/lower limit error, CJ error, B line error
2 Internal data error	The value becomes "1" if an error occurs on even one of PV14 to PV16.	Memory alarm has occurred in RAM or EEPROM.
3 Reserved	"0" at all times	-
4 Reserved	"0" at all times	-
5 Reserved	"0" at all times	-
6 CH1 motor adjustment error	The value becomes "1" if the position proportional motor adjustment does not normally end.	The value of "1" is maintained until the power is reapplied or the adjustment normally ends.
7 CH2 motor adjustment error		
8 Reserved	"0" at all times	
9 PV error of PV channel 1	The value becomes "1" if an error occurs on even one of the bits related to PV channel 1 for PV input error.	Either upper/lower limit alarm or A/D error has occurred in PV channel 1.
10 PV error of PV channel 2	The value becomes "1" if an error occurs on even one of the bits related to PV channel 2 for PV input error.	Either upper/lower limit alarm or A/D error has occurred in PV channel 2.
11 PV error of PV channel 3	The value becomes "1" if an error occurs on even one of the bits related to PV channel 3 for PV input error.	Either upper/lower limit alarm or A/D error has occurred in PV channel 3.
12 PV error of PV channel 4	The value becomes "1" if an error occurs on even one of the bits related to PV channel 4 for PV input error.	Either upper/lower limit alarm or A/D error has occurred in PV channel 4.
13 Reserved	"0" at all times	-
14 RAM parameter checksum error	At error occurrence = 1	Checksum error in RAM (parameter area)
15 RAM adjustment checksum error	At error occurrence = 1	Checksum error in RAM (adjustment area)
16 EEPROM all areas checksum error	At error occurrence = 1	Checksum error occurred in EEPROM.

Note: The data of all 16 bits is obtained as the data of a single signed word (-32768 to +32767, 8000H to 7FFFH).

<Read example>

When a PV error at PV channel 1 occurs, 1 and 9 turn ON simultaneously, and send and response are as follows:

Send: RS, 1001W, 1
 Response: 00, 257

● Table 10-2: PV alarm details

2 ¹⁵	2 ¹⁴	2 ¹³	2 ¹²	2 ¹¹	2 ¹⁰	2 ⁹	2 ⁸	2 ⁷	2 ⁶	2 ⁵	2 ⁴	2 ³	2 ²	2 ¹	2 ⁰
16	15	14	13	12	11	10	9	8	7	6	5	4	3	2	1

	Item	Value	Remarks
1	PV channel 1 upper limit alarm	At error occurrence = 1	An error occurs when the range upper limit+10% is exceeded. The manipulated variable is output when a PV alarm occurs.*1
2	PV channel 2 upper limit alarm	At error occurrence = 1	
3	PV channel 3 upper limit alarm	At error occurrence = 1	
	Feedback input 1 Y line break	At error occurrence = 1	No special action
4	PV channel 4 upper limit alarm	At error occurrence = 1	Same as *1
	Feedback input 2 Y line break	At error occurrence = 1	No special action
5	PV channel 1 lower limit alarm	At error occurrence = 1	An error occurs when the range upper limit-10% is exceeded. The manipulated variable is output when a PV alarm occurs.*2
6	PV channel 2 lower limit alarm	At error occurrence = 1	
7	PV channel 3 lower limit alarm	At error occurrence = 1	
	Feedback input 1 G line break	At error occurrence = 1	No special action
8	PV channel 4 lower limit alarm	At error occurrence = 1	Same as *2
	Feedback input 2 G line break	At error occurrence = 1	No special action
9	PV channel 1 CJ/BC line alarm	At error occurrence = 1	CJ malfunction (thermocouple) B or C line break (RTD) The manipulated variable is output when a PV alarm occurs.
10	PV channel 2 CJ/BC line alarm	At error occurrence = 1	CJ malfunction (thermocouple) B or C line break (RTD) The manipulated variable is output when a PV alarm occurs.
11	PV channel 3 CJ/BC line alarm	At error occurrence = 1	CJ malfunction (thermocouple) B or C line break (RTD) The manipulated variable is output when a PV alarm occurs.
	Feedback input 1 T line break	At error occurrence = 1	No special action
12	PV channel 4 CJ/BC line alarm	At error occurrence = 1	CJ malfunction (thermocouple) B or C line break (RTD) The manipulated variable is output when a PV alarm occurs.
	Feedback input 2 T line break	At error occurrence = 1	No special action
13	PV channel 1 A/D alarm	At error occurrence = 1	An error occurs when the A/D converter does not function. The manipulated variable is output when a PV alarm occurs.
14	PV channel 2 A/D alarm	At error occurrence = 1	
15	PV channel 3 A/D alarm	At error occurrence = 1	
16	PV channel 4 A/D alarm	At error occurrence = 1	

Note: The data of all 16 bits is obtained as the data of a single signed word (-32768 to +32767, 8000H to 7FFFH).

! Handling Precautions

When the setting for using the remote SP is used, and the local SP is selected, the PV upper/lower alarm does not occur on the channel to which the remote SP is entered.

PV upper/lower alarms when remote SP is used (word 3519, 7519 are set to "1")

	During Local SP				During Remote SP			
	1	2	3	4	1	2	3	4
PV channel	1	2	3	4	1	2	3	4
2-channel model	ON	OFF	—	—	ON	ON	—	—
4-channel model	ON	ON	OFF	OFF	ON	ON	ON	ON

ON: W/ PV upper/lower limit alarm

OFF: W/out upper/lower limit alarm

● **Table 10-3: Control related status**

2 ¹⁵	2 ¹⁴	2 ¹³	2 ¹²	2 ¹¹	2 ¹⁰	2 ⁹	2 ⁸	2 ⁷	2 ⁶	2 ⁵	2 ⁴	2 ³	2 ²	2 ¹	2 ⁰
16	15	14	13	12	11	10	9	8	7	6	5	4	3	2	1

	Item	Value	Remarks
1	Channel 1 self-tuning correction/correction standby	During correction standby = 1	-
2	Channel 1 current transformer measurement disabled/enabled	When measurement is enabled = 1	-
3	Channel 1 position proportional inference state	0: Potentiometer feedback value in use 1: Inferred feedback value in use	Meaningful only while position proportional control being used
4	Channel 1 position proportional adjustment state	0: Motor running 1: Motor being adjusted	Meaningful only while position proportional control being used
5	Channel 2 self-tuning correction/correction standby	During correction standby = 1	-
6	Channel 2 current transformer measurement disabled/enabled	When measurement is enabled = 1	-
7	Channel 2 position proportional inference state	0: Potentiometer feedback value in use 1: Inferred feedback value in use	Meaningful only while position proportional control being used
8	Channel 1 position proportional adjustment state	0: Motor running 1: Motor being adjusted	Meaningful only while position proportional control being used
9	Channel 3 self-tuning correction/correction standby	During correction standby = 1	-
10	Channel 3 current transformer measurement disabled/enabled	When measurement is enabled = 1	-
11	Channel 1 motor action close	Output on the open side 0: OFF 1: ON	-
12	Channel 1 motor action open	Output on the close side 0: OFF 1: ON	-
13	Channel 4 self-tuning correction/correction standby	During correction standby = 1	-
14	Channel 4 current transformer measurement disabled/enabled	When measurement is enabled = 1	-
15	Channel 2 motor action close	Output on the open side 0: OFF 1: ON	-
16	Channel 2 motor action open	Output on the close side 0: OFF 1: ON	-

Note: The data of all 16 bits is obtained as the data of a single signed word (−32768 to +32767, 8000H to 7FFFH).

● **Table 10-4: Internal calculation result of event output / external switch input (1044W)**

	2^{15}	2^{14}	2^{13}	2^{12}	2^{11}	2^{10}	2^9	2^8	2^7	2^6	2^5	2^4	2^3	2^2	2^1	2^0
	16	15	14	13	12	11	10	9	8	7	6	5	4	3	2	1

	Item	Value	Remarks
1	Event output internal calculation result 1	0: OFF 1: ON	Internal event calculation result. This is the calculation result of a function indicated in the loader as event output related and defined in an event table. (It is not the output state of the output terminal or external bus.)
2	Event output internal calculation result 2	0: OFF 1: ON	
3	Event output internal calculation result 3	0: OFF 1: ON	
4	Event output internal calculation result 4	0: OFF 1: ON	
5	Event output internal calculation result 5	0: OFF 1: ON	
6	Event output internal calculation result 6	0: OFF 1: ON	
7	Event output internal calculation result 7	0: OFF 1: ON	
8	Event output internal calculation result 8	0: OFF 1: ON	
9	External switch input internal calculation result 1	0: OFF 1: ON	External switch input calculation result. This is the calculation result of a function indicated in the loader as "external switch input." (It is not the external switch input or external bus input terminal state. For the input terminal state, refer to Table 10-5.)
10	External switch input internal calculation result 2	0: OFF 1: ON	
11	External switch input internal calculation result 3	0: OFF 1: ON	
12	External switch input internal calculation result 4	0: OFF 1: ON	
13	External switch input internal calculation result 5	0: OFF 1: ON	
14	External switch input internal calculation result 6	0: OFF 1: ON	
15	External switch input internal calculation result 7	0: OFF 1: ON	
16	External switch input internal calculation result 8	0: OFF 1: ON	

Note: The data of all 16 bits is obtained as the data of a single signed word (–32768 to +32767, 8000H to 7FFFH).

● **Table 10-5: External switch input state (1045W)**

	2^{15}	2^{14}	2^{13}	2^{12}	2^{11}	2^{10}	2^9	2^8	2^7	2^6	2^5	2^4	2^3	2^2	2^1	2^0
	16	15	14	13	12	11	10	9	8	7	6	5	4	3	2	1

	Item	Value	Remarks
1	External switch input 1	0: OFF 1: ON	External switch models only External switch input terminal on/off state.
2	External switch input 2	0: OFF 1: ON	
3	External switch input 3	0: OFF 1: ON	
4	External switch input 4	0: OFF 1: ON	
5	External switch bus input 1	0: OFF 1: ON	External bus input on/off state
6	External switch bus input 2	0: OFF 1: ON	
7	External switch bus input 3	0: OFF 1: ON	
8	External switch bus input 4	0: OFF 1: ON	
9	Reserved	"0" at all times	-
10	Reserved	"0" at all times	-
11	Reserved	"0" at all times	-
12	Reserved	"0" at all times	-
13	Reserved	"0" at all times	-
14	Reserved	"0" at all times	-
15	Reserved	"0" at all times	-
16	Reserved	"0" at all times	-

Note: The data of all 16 bits is obtained as the data of a single signed word (–32768 to +32767, 8000H to 7FFFH).

● **Table 10-6: Event output/control output state (1046W)**

2 ¹⁵	2 ¹⁴	2 ¹³	2 ¹²	2 ¹¹	2 ¹⁰	2 ⁹	2 ⁸	2 ⁷	2 ⁶	2 ⁵	2 ⁴	2 ³	2 ²	2 ¹	2 ⁰
16	15	14	13	12	11	10	9	8	7	6	5	4	3	2	1

	Item	Value	Remarks
1	Event output 1	0: OFF 1: ON	Event output terminal on/off state. Enabled only on models with an event output terminal. Indefinite value on other models.
2	Event output 2	0: OFF 1: ON	
3	Event output 3	0: OFF 1: ON	
4	Event output 4	0: OFF 1: ON	
5	Event bus output 1	0: OFF 1: ON	External bus output on/off state
6	Event bus output 2	0: OFF 1: ON	
7	Event bus output 3	0: OFF 1: ON	
8	Event bus output 4	0: OFF 1: ON	
9	OUT1	0: OFF 1: ON	Control output terminal on/off state. (In the case of 2-channel models, value is indefinite as OUT3 and OUT4 do not have terminals)
10	OUT2	0: OFF 1: ON	
11	OUT3	0: OFF 1: ON	
12	OUT4	0: OFF 1: ON	
13	Reserved	Not fixed	-
14	Reserved	Not fixed	-
15	Reserved	Not fixed	-
16	Reserved	Not fixed	-

Note: The data of all 16 bits is obtained as the data of a single signed word (–32768 to +32767, 8000H to 7FFFH).

● **Table 10-7: Latch release**

2 ¹⁵	2 ¹⁴	2 ¹³	2 ¹²	2 ¹¹	2 ¹⁰	2 ⁹	2 ⁸	2 ⁷	2 ⁶	2 ⁵	2 ⁴	2 ³	2 ²	2 ¹	2 ⁰
16	15	14	13	12	11	10	9	8	7	6	5	4	3	2	1

	Item	Value	Remarks
1	Event output 1	0: No operation 1: Cancel	-
2	Event output 2	0: No operation 1: Cancel	-
3	Event output 3	0: No operation 1: Cancel	-
4	Event output 4	0: No operation 1: Cancel	-
5	Event bus output 1	0: No operation 1: Cancel	-
6	Event bus output 2	0: No operation 1: Cancel	-
7	Event bus output 3	0: No operation 1: Cancel	-
8	Event bus output 4	0: No operation 1: Cancel	-
9	OUT1	0: No operation 1: Cancel	-
10	OUT2	0: No operation 1: Cancel	-
11	OUT3	0: No operation 1: Cancel	-
12	OUT4	0: No operation 1: Cancel	-
13	Reserved	“0” at all times	-
14	Reserved	“0” at all times	-
15	Reserved	“0” at all times	-
16	Reserved	“0” at all times	-

Note: The data of all 16 bits is obtained as the data of a single signed word (–32768 to +32767, 8000H to 7FFFH).

● **Table 10-8: Output assignments 1 (7702W, 7707W, etc.)**

2^{15}	2^{14}	2^{13}	2^{12}	2^{11}	2^{10}	2^9	2^8	2^7	2^6	2^5	2^4	2^3	2^2	2^1	2^0
16	15	14	13	12	11	10	9	8	7	6	5	4	3	2	1

	Item	Value	Remarks
1	EV_TBL1 internal calculation result	0: OFF 1: ON	The 1: ON bit state is used for output.
2	EV_TBL2 internal calculation result	0: OFF 1: ON	
3	EV_TBL3 internal calculation result	0: OFF 1: ON	
4	EV_TBL4 internal calculation result	0: OFF 1: ON	
5	EV_TBL5 internal calculation result	0: OFF 1: ON	
6	EV_TBL6 internal calculation result	0: OFF 1: ON	
7	EV_TBL7 internal calculation result	0: OFF 1: ON	
8	EV_TBL8 internal calculation result	0: OFF 1: ON	
9	External switch input 1	0: OFF 1: ON	
10	External switch input 2	0: OFF 1: ON	
11	External switch input 3	0: OFF 1: ON	
12	External switch input 4	0: OFF 1: ON	
13	OUT1 control calculation result	0: OFF 1: ON	
14	OUT2 control calculation result	0: OFF 1: ON	
15	OUT3 control calculation result	0: OFF 1: ON	
16	OUT4 control calculation result	0: OFF 1: ON	

Note: The data of all 16 bits is obtained as the data of a single signed word (–32768 to +32767, 8000H to 7FFFH).

● **Table 10-9: Output assignments 2 (7701W, 7706W, etc.)**

2^{15}	2^{14}	2^{13}	2^{12}	2^{11}	2^{10}	2^9	2^8	2^7	2^6	2^5	2^4	2^3	2^2	2^1	2^0
16	15	14	13	12	11	10	9	8	7	6	5	4	3	2	1

	Item	Value	Remarks
1	RSW_TBL1 internal calculation result	0: OFF 1: ON	The 1: ON bit state is used for output.
2	RSW_TBL2 internal calculation result	0: OFF 1: ON	
3	RSW_TBL3 internal calculation result	0: OFF 1: ON	
4	RSW_TBL4 internal calculation result	0: OFF 1: ON	
5	RSW_TBL5 internal calculation result	0: OFF 1: ON	
6	RSW_TBL6 internal calculation result	0: OFF 1: ON	
7	RSW_TBL7 internal calculation result	0: OFF 1: ON	
8	RSW_TBL8 internal calculation result	0: OFF 1: ON	
9	External switching bus input 1	0: OFF 1: ON	
10	External switching bus input 2	0: OFF 1: ON	
11	External switching bus input 3	0: OFF 1: ON	
12	External switching bus input 4	0: OFF 1: ON	
13	Communications DI1	0: OFF 1: ON	
14	Communications DI2	0: OFF 1: ON	
15	Communications DI3	0: OFF 1: ON	
16	Communications DI4	0: OFF 1: ON	

Note: The data of all 16 bits is obtained as the data of a single signed word (–32768 to +32767, 8000H to 7FFFH).

● **Table 10-10: Output assignments 3 (7761W to 7772W)**

2 ¹⁵	2 ¹⁴	2 ¹³	2 ¹²	2 ¹¹	2 ¹⁰	2 ⁹	2 ⁸	2 ⁷	2 ⁶	2 ⁵	2 ⁴	2 ³	2 ²	2 ¹	2 ⁰
16	15	14	13	12	11	10	9	8	7	6	5	4	3	2	1

	Item	Value	Remarks
1	Communications DI5	0: OFF 1: ON	The 1: ON bit state is used for output.
2	Communications DI6	0: OFF 1: ON	
3	Communications DI7	0: OFF 1: ON	
4	Communications DI8	0: OFF 1: ON	
5	Communications DI9	0: OFF 1: ON	
6	Communications DI10	0: OFF 1: ON	
7	Communications DI11	0: OFF 1: ON	
8	Communications DI12	0: OFF 1: ON	
9	Undefined	"0" at all times	
10	Undefined	"0" at all times	
11	Undefined	"0" at all times	
12	Undefined	"0" at all times	
13	Undefined	"0" at all times	
14	Undefined	"0" at all times	
15	Undefined	"0" at all times	
16	Undefined	"0" at all times	

Note: The values ranging from -32768 to +32767 (i.e. 8000H to 7FFFH) are able to write. However, the undefined bits do not operate because they are reserved. Always set to 0.

● **Table 10-11: Input assignments 1 (7604W, 7610W, etc.)**

2 ¹⁵	2 ¹⁴	2 ¹³	2 ¹²	2 ¹¹	2 ¹⁰	2 ⁹	2 ⁸	2 ⁷	2 ⁶	2 ⁵	2 ⁴	2 ³	2 ²	2 ¹	2 ⁰
16	15	14	13	12	11	10	9	8	7	6	5	4	3	2	1

	Item	Value	Remarks
1	External switch input 1	0: OFF 1: ON	The 1: ON bit state is used for on/off of external switch input.
2	External switch input 2	0: OFF 1: ON	
3	External switch input 3	0: OFF 1: ON	
4	External switch input 4	0: OFF 1: ON	
5	External switching bus input 1	0: OFF 1: ON	
6	External switching bus input 2	0: OFF 1: ON	
7	External switching bus input 3	0: OFF 1: ON	
8	External switching bus input 4	0: OFF 1: ON	
9	EV_TBL1 internal calculation result	0: OFF 1: ON	
10	EV_TBL2 internal calculation result	0: OFF 1: ON	
11	EV_TBL3 internal calculation result	0: OFF 1: ON	
12	EV_TBL4 internal calculation result	0: OFF 1: ON	
13	EV_TBL5 internal calculation result	0: OFF 1: ON	
14	EV_TBL6 internal calculation result	0: OFF 1: ON	
15	EV_TBL7 internal calculation result	0: OFF 1: ON	
16	EV_TBL8 internal calculation result	0: OFF 1: ON	

Note: The data of all 16 bits is obtained as the data of a single signed word (-32768 to +32767, 8000H to 7FFFH).

● **Table 10-12: Input assignments 2 (7603W, 7609W, etc.)**

2 ¹⁵	2 ¹⁴	2 ¹³	2 ¹²	2 ¹¹	2 ¹⁰	2 ⁹	2 ⁸	2 ⁷	2 ⁶	2 ⁵	2 ⁴	2 ³	2 ²	2 ¹	2 ⁰
16	15	14	13	12	11	10	9	8	7	6	5	4	3	2	1

	Item	Value	Remarks
1	Reserved	"0" at all times	The 1: ON bit state is used for on/off of external switch input.
2	Reserved	"0" at all times	
3	Reserved	"0" at all times	
4	Reserved	"0" at all times	
5	Reserved	"0" at all times	
6	Reserved	"0" at all times	
7	Reserved	"0" at all times	
8	Reserved	"0" at all times	
9	Event output 1	0: OFF 1: ON	
10	Event output 2	0: OFF 1: ON	
11	Event output 3	0: OFF 1: ON	
12	Event output 4	0: OFF 1: ON	
13	Communications DI1	0: OFF 1: ON	
14	Communications DI2	0: OFF 1: ON	
15	Communications DI3	0: OFF 1: ON	
16	Communications DI4	0: OFF 1: ON	

Note: The data of all 16 bits is obtained as the data of a single signed word (-32768 to +32767, 8000H to 7FFFH).

● **Table 10-13: Input assignments 3 (7649W to 7656W)**

2 ¹⁵	2 ¹⁴	2 ¹³	2 ¹²	2 ¹¹	2 ¹⁰	2 ⁹	2 ⁸	2 ⁷	2 ⁶	2 ⁵	2 ⁴	2 ³	2 ²	2 ¹	2 ⁰
16	15	14	13	12	11	10	9	8	7	6	5	4	3	2	1

	Item	Value	Remarks
1	Communications DI5	0: OFF 1: ON	The 1: ON bit state is used for on/off of external switch input.
2	Communications DI6	0: OFF 1: ON	
3	Communications DI7	0: OFF 1: ON	
4	Communications DI8	0: OFF 1: ON	
5	Communications DI9	0: OFF 1: ON	
6	Communications DI10	0: OFF 1: ON	
7	Communications DI11	0: OFF 1: ON	
8	Communications DI12	0: OFF 1: ON	
9	Undefined	"0" at all times	
10	Undefined	"0" at all times	
11	Undefined	"0" at all times	
12	Undefined	"0" at all times	
13	Undefined	"0" at all times	
14	Undefined	"0" at all times	
15	Undefined	"0" at all times	
16	Undefined	"0" at all times	

Note: The values ranging from -32768 to +32767 (i.e. 8000H to 7FFFH) are able to write. However, the undefined bits do not operate because they are reserved. Always set to 0.

● **Table 10-14: Communications DI**

2¹⁵ 2¹⁴ 2¹³ 2¹² 2¹¹ 2¹⁰ 2⁹ 2⁸ 2⁷ 2⁶ 2⁵ 2⁴ 2³ 2² 2¹ 2⁰

16	15	14	13	12	11	10	9	8	7	6	5	4	3	2	1
----	----	----	----	----	----	----	---	---	---	---	---	---	---	---	---

	Item	Value	Remarks
1	Communications DI5	0: OFF 1: ON	-
2	Communications DI6	0: OFF 1: ON	-
3	Communications DI7	0: OFF 1: ON	-
4	Communications DI8	0: OFF 1: ON	-
5	Communications DI9	0: OFF 1: ON	-
6	Communications DI10	0: OFF 1: ON	-
7	Communications DI11	0: OFF 1: ON	-
8	Communications DI12	0: OFF 1: ON	-
9	Undefined	0: OFF 1: ON	-
10	Undefined	0: OFF 1: ON	-
11	Undefined	0: OFF 1: ON	-
12	Undefinedt	0: OFF 1: ON	-
13	Undefined	0: OFF 1: ON	-
14	Undefined	0: OFF 1: ON	-
15	Undefined	0: OFF 1: ON	-
16	Undefined	0: OFF 1: ON	-

Note: The values ranging from -32768 to +32767 (i.e. 0000H to FFFFH) are writable. However, the bits (13) to (16) do not operate because they are reserved. Always set to 0.

10 - 9 Detail Explanation on Communication Conditions

The parameters of which write conditions are changed according to various conditions are indicated as follows on each type:

- ◆ Target parameter
 - Conditions under which writing cannot be made.

■ Write Conditions

● Parameters of which write conditions are changed according to operation mode

- ◆ AUTO/MANUAL switching
 - At ON/OFF control
- ◆ Manual control output value
 - At AUTO
 - At ON/OFF control
- ◆ Motor adjustment start
 - At MANUAL
 - At READY
 - At generation of feedback input alarm
 - Position proportional type of “3:MFB or 4:No MFB (position adjustment at power supply application)”
 - AT startup
- ◆ AT start
 - AT start assigned to RSW
 - FB in adjustment
 - ON/OFF in operation
 - Reference: Writing can be made in MANUAL, READY and PV alarm generation. However, AT does not start.

● Parameters of which write conditions are changed according to other settings

- ◆ SP group switching
 - At setting of single SP
- ◆ LOCAL/REMOTE SP switching
 - REMOTE/LOCAL switching set to RSW
 - Setting to no use of RSP
 - HEAT/COOL in use
- ◆ PV range upper/lower limit values
 - At range selection for thermocouple or RTD
- ◆ Decimal point
 - When a range number which cannot apply a decimal point to thermocouple or RTD is selected .
- ◆ When switching of each function is set to RSW function
 - At SP group switching – SP group switching
 - At AUTO/MANUAL switching – AUTO/MANUAL switching
 - At RUN/READY switching – RUN/READY switching
 - At LOCAL/REMOTE SP switching – LOCAL/REMOTE SP switching
 - At AT start switching - AT start
 - At switching to use inter-channel deviation control - switching to use inter-channel deviation

● **Parameters of which other write conditions are changed**

- ◆ SP group in use
 - SP3 and SP4 selection on 4CH model
- ◆ Communication conditions (transmission speed, communication system and communication type)
 - Setting from RS-485 (can set from loader only)
- ◆ Parameters related with auxiliary output
- ◆ Parameters (S type) related with position proportioning
- ◆ Parameters (S type) related with heat/cool control
- ◆ Parameters (S type) related with power saving
- ◆ LOCAL/REMOTE SP switching (S type)
- ◆ 3/4CH target parameters (2ch model)
 - Write conditions according to model number (write to a function not available)

■ **Write Range**

● **Parameters of which write range is changed according to other parameters**

- ◆ SP value in use
 - Range number selected
- ◆ SP group in use
 - 2/4CH model
- ◆ SP value
 - Range number selected
- ◆ MV upper/lower limit values
 - AUX: available or not available
- ◆ Event setting range (main and subsidiary)
 - Event type
- ◆ Decimal point position
- ◆ PV range upper/lower limit values
- ◆ Self-tuning start-up band
 - Range type
- ◆ SP limit upper/lower limit values
 - PV range upper/lower limit values

● **Parameters of which write range is changed according to model number**

- ◆ Target channel of each parameter
 - Setting of CH not available
- ◆ Time proportional cycle
 - Relay output and voltage output

■ Constant Write Inhibit

The parameters below will not correctly function if constant writing is performed.
Write only one time when required.

- ◆ Range No.
- ◆ Temperature unit
- ◆ Decimal point position
- ◆ SP value in use (only at use of standby reset for SP setting)
- ◆ Use of heat/cool
- ◆ Use of power saving
- ◆ Position proportional control type
- ◆ Selection of position proportional motor resistor value
- ◆ Control method
- ◆ Proportional band
- ◆ Reset time
- ◆ Rate time
- ◆ MV lower limit value
- ◆ MV upper limit value
- ◆ Manual reset
- ◆ Self-tuning start-up band
- ◆ Latch release (as becoming constant release status)
- ◆ Auto-tuning start/stop

10 - 10 Cautions when Making Communications Programs for the Master Station

Pay attention to the following points when making communications programs:

- The longest response time on the device is two seconds. For this reason, set the response time-out to two seconds.
- Resend the same message if there is no response within two seconds.
Set a communications error to occur if there is no response even after two retries.
- Be sure to make the above resends if the message cannot be send correctly due to the influence of noise, for example, during communications.



Note

When the master station resends the message, alternatively use the device judgment codes “X” and “x.” This is handy as you can tell whether or not the received message is the previously received message.

● Example of communications program

The program example shown here is written in Fujitsu F-BASIC 6.0 (Windows version).

This program is given here as a reference when the user makes a program, and does not assure all operations.

Check the communications conditions and device address of the device before executing this program.

This program is used for reading and writing data. When the program is executed, the application layers of the instruction message and response message communicated are indicated.

```

Instruction message application layer
RS. 123W, 4
Response message application layer
00, 10, -20, 0, 40
Instruction message application layer
WS, 234W, 1, 1
Response message application layer
00
  
```

Example of execution results display

- Communication settings
Set the device address of the other station to “ADDRESS.”
Open the RS-232C and call the subroutine *INIT_DATA.
- Data reading
After setting the read start data address to “READ_ADRS” and the number of read data items to “READ_LEN”, call the subroutine *DATA_READ.
This program permits four data items to be read from data address “123”.
Change the setting to match the device used.
- Data writing
After setting the write start data address to “WRITE_ADRS”, the number of write data items to “WRITE_LEN”, and the write data to “WRITE_DATA”, call the subroutine *DATA_WRITE.
This program permits two data items to be written from data address “234”.
Change the setting to match the device used.

● **Data read/write sample program**

The sample program is installed in the folder containing the installed loader.
In the standard installation, the sample program is as follows:

c : \programfiles\slp\slpd10\sample95.bas

 **Handling Precautions**

Yamatake Corporation shall not be liable for any damages resulting from the use of this program sample.

Chapter 11. MODBUS COMMUNICATIONS FUNCTIONS

11 - 1 Outline of Communications

■ Features

The features of the DMC10's communications functions are as follows:

- Gives the option of CPL communications or MODBUS (ASCII, RTU) communications.
- Up to 15 DMC10s can be connected to a single master station as a host device. The CMC10B cannot be connected if MODBUS is used.
- When the communications specifications of the host device conform to the RS-232C interface, RS-232C/RS-485 conversion can be performed by the communications converter CMC10L (sold separately).
- Almost all of the parameters held by the device can be communicated. For details on communications parameters, see "[10-8 List of All Communications Parameters](#)" (page 10-16).
- Two types of address arrangements are available for frequently used parameters. Parameter groups that can be handled by single commands can be selected according to the application.
- A maximum transmission speed of 19200bps is supported.

■ Initial Setting

The following setups are required for starting communications:

Setting Item	Setting Location	Setting Range	Factory Setting
Communication type	Set on PC Loader.	0 : CPL 1 : MODBUS (ASCII format) 2 : MODBUS (RTU format)	0 : CPL
Station address	Set on rotary switch for station address.	0 to F	
Transmission speed	Set on PC Loader.	0 : 2400bps 1 : 4800bps 2 : 9600bps 3 : 19200bps	3 : 19200bps
Data format	Set on PC Loader.	0 : 8 bits, even parity, 1 stop bit 1 : 8 bits, no parity, 2 stop bits	0 : 8 bits, even parity, 1 stop bit
Min. response time	Set on PC Loader.	0 : 1ms 1 : 10ms 2 : 100ms 3 : 200ms	1 : 10ms

■ Communications Procedures

The communications procedure is as follows:

- (1) The instruction message is sent from the host device (master station) to the DMC10 unit (slave station) to communicate with.
- (2) The slave station receives the instruction message, and performs read or write processing according to the content of the message.
- (3) The slave station sends a message corresponding to the processing content as the response message.
- (4) The master station receives the response message.

11 - 2 Message Structure

■ Message Structure

The below shows the message structure.

All messages are expressed in hexadecimal.

● MODBUS ASCII

All messages other than delimiters are written in hexadecimal ASCII codes.

A message of MODBUS (ASCII) consists of (1) to (6) below.

(3) stores commands, which are transmission contents from the master station and responses, which are transmission contents from the slave station.

All messages use ASCII codes. (Each slot below corresponds to one character.)

(1) Beginning of message (expressed with ASCII code 3AH: colon)

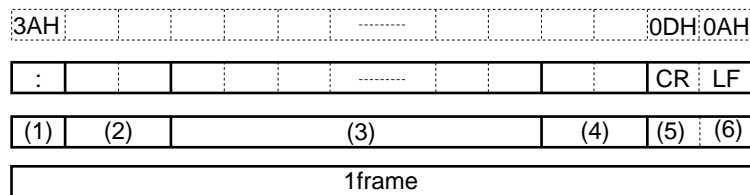

(2) Station address (2 bytes)

(3) Transmission message, response message

(4) Checksum (2-byte LRC)

(5) CR (delimiter)

(6) LF (delimiter)

- Colon (3AH)
When a colon is received, it has the same function as STX of CPL. See "**Description of data items/STX**" of CPL communications.
- Station address
Has the same function as that of the CPL station address. See "**●Description of data items**" (page 10-4), for details.
- Checksum (LRC)
Has the same function as that of the CPL station address. See "**●Description of data items**" (page 10-4), for details.
However, the method of creating a checksum is different from that of CPL.
Checksum creation method
 - (1) Add transmission data in 1-byte units starting from the character next to the colon (3AH) at the beginning of a message. (Note that the value to be added is not an ASCII character value of the transmission message but the transmission data before converted to an ASCII character. It is (2) to (3) in the figure above that are added.)
 - (2) Find a 2's complement of the addition result.
 - (3) Convert the lower 1 byte of the addition result to a character code.
- CR/LF
Has the same function as that of CR/LF of CPL. See "**●Description of data items**" (page 10-4), for details.

● MODBUS RTU

All messages are written in binary data.

A MODBUS (RTU) message consists of (1) to (3) below.

(2) stores commands, which are transmission contents from the master station and responses, which are transmission contents from the slave station.

All messages use binary data. (Each slot below corresponds to one character.)

(1) Station address (1 byte)

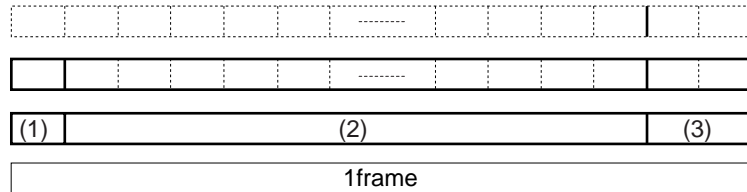

(2) Transmission message, response message

(3) Checksum (2 bytes)

- Station address

Has the same function as that of the CPL station address. See

"●Description of data items" (page 10-4), for details.

- Checksum

Has the same function as that of the CPL station address. See

"●Description of data items" (page 10-4), for details.

However, unlike CPL, the method of creating a checksum carries out a CRC check.

The checksum (CRC) creation method is shown below.

```

/* CRC calculation */
/* Input    unsigned char length :Number of transmission bytes    */
/*          unsigned char * top   :Transmission data start pointer */
/* Output   unsigned short CRC   :CRC calculation result          */
unsigned short crc16( unsigned char length, unsigned char * top )
{
    unsigned short CRC= 0xffff;
    unsigned short next;
    unsigned short carry;
    unsigned short n;
    unsigned char  crcl;

    while ( length-- ) {
        next = (unsigned short)* top;
        CRC ^= next;
        for (n = 0; n < 8; n++) {
            carry = CRC & 1;
            CRC >>= 1;
            if (carry) {
                CRC ^= 0xA001;
            }
        }
        top++;
    }

    crcl = (CRC & 0xff00)>>8;
    CRC <<= 8;
    CRC |= crcl;

    return CRC;
}

```

- 1-frame end judgment
 A message end (1-frame end) is determined when a time specified for each transmission speed has passed during which no character is received. It is considered that 1 frame has ended when the following character is not received by the time the following timeout time passes.
 However, the timeout time has a fluctuation of +/-1 ms from values in the following table.

Table 1.5

Set Transmission Speed (bps)	Timeout Time
2400	20 ms or more
4800	10 ms or more
9600	5 ms or more
19200	5 ms or more

■ Transmission Message

Details of a transmission message are as follows.

Item	Content	
	ASCII (ASCII character notation)	RTU (binary notation)
Command Read	"03"	03H
Write	"10"	10H
Word address	"03E9"	03E9H
Read count	Numerical value expressed in characters, 1-word units	—
Write value	—	Numerical value expressed in binaries, word units

■ Response Time

The time after one full frame of a transmission message is received until the instrument starts to reply a response message is a time (ms) expressed by "minimum communications response time + minimum communications response time (added value) + timeout time".

See "**●Min. communications response time**" and "**●Min. communications response time added value (ms)**" (page 8-14), for details.

■ Other Specifications

See "**10-7 Reception and Transmission Timing**" (page 10-15), for details.

- Supports MODBUS Class 0.
- Error end code 01: Command error
 02: Address error
 03: Data error
- Maximum communications data word count

Data count	ASCII	RTU
03 (READ)	16	32
10 (WRITE)	16	32

- Other
 For details of the MODBUS specification, see OPEN MODBUS/TCP SPECIFICATION (Release 1.0) of MODBUS Corporation.

11 - 3 Description of Commands

This protocol is compliant to Modicon's MODBUS protocol.

MODBUS communication DMC10 supported has two encoding, RTU encoding and ASCII encoding.

Conformance class of that is Class 0.

■ RTU Encoding

● Structure of request

- Request of reading multiple registers (Function code: 03 hex.)

Device address	FunctionCode	Resister address	Word count	CRC	Time out
1byte	03 (hex.)	2bytes	2bytes	2bytes	See Table 1.5 (11-4 page)



Note

Device address: Our product address

(ex. This is on the front panel in case of DMC10)

Resister address: See the communication table of each product manual

Word count: Number of resister you want to read (This is up to 32)

CRC: See the Modicon's Specification or see [sample program 11-3 page](#)

- Request of writing multiple resisters (Function code: 10 hex.)

Device address	FunctionCode	Resister address	Word count	Byte count	Resister values	CRC	Time out
1byte	10 (hex.)	2bytes	2bytes	1byte	(byte count) bytes	2bytes	See Table 1.5 (11-4 page)



Note

Device address: Our product address

(ex. This is on the front panel in case of DMC10)

Resister address: See the communication resister table of each product manual

Word count: Number of resister you want to read (This is up to 32)

Byte count: byte count = 2 x word count (This is up to 64)

Resister value: Data you want to write

CRC: See the Modicon's Specification or see [sample program 11-3 page](#)

● Structure of response

- Response of reading multiple resisters

Device address	FunctionCode	Byte count	Resister values	CRC	Time out
1byte	03 (hex.)	1byte	(byte count) bytes	2bytes	See Table 1.5 (11-4 page)



Note

Device address: Device address: Product address you read

Byte count: 2 x Number of resister you read

Resister value: Data you read

CRC: See the Modicon's Specification or see [sample program 11-3 page](#)

- Response of writing multiple resisters

Device address	FunctionCode	Resister address	Word count	CRC	Time out
1byte	10 (hex.)	2bytes	2bytes	2bytes	See Table 1.5 (11-4 page)



Note

Device address: Product address you wrote

Resister address: Resister address you wrote

Word count: Number of resister you wrote

CRC: See the Modicon's Specification or see [sample program 11-3 page](#)

● Structure of exception response

- Exception response of reading multiple registers

Device address	FunctionCode	Exception code	CRC	Time out
1byte	83 (hex.)	1byte	2bytes	See Table 1.5 (11-4 page)

 **Note**

Device address: Product address you wrote
 Exception code: See table 1.3
 CRC: See the Modicon's Specification or see [sample program 11-3 page](#)

- Exception response of writing multiple registers

Device address	Function code	Exception code	CRC	Time out
1byte	90 (hex.)	1byte	2bytes	See Table 1.5 (11-4 page)

 **Note**

Device address: Product address you wrote
 Exception code: See table 1.3
 CRC: See the Modicon's Specification or see [sample program 11-3 page](#)

Table 1.3: Exception code

Code	Contents	Cause
1	Illegal Function	Undefined function code
2	Illegal Data address	Undefined data address
3	Illegal Data value	Data range over Note:Go on writing except range over data

■ ASCII Encoding

● Structure of request

- Request of reading multiple registers (Function code: 03)

Start code	Device address	Function code	Resister address	Word count	LRC	Delimiter	Delimiter
:	2chars	03 (hex.)	4chars	4chars	2chars	CR	LF

 **Note**

Start code: Start of request
 Device address: Our product address
 (ex. This is on the front panel in case of DMC10)
 Resister address: See the communication table of each product manual
 Word count: Number of resister you want to read (This is up to 16)
 LRC: Add from the character next to the start code to resister values together and complement it
 Delimiter: CR code
 Delimiter: LF code

• Request of writing multiple registers (Function code: 10)

Start code	Device address	Function code	Resister address	Word count	Byte count	Resister values	LRC	Delimiter	Delimiter
:	2chars	10 (hex.)	4chars	4chars	2chars	(2 x byte count)chars	2chars	CR	LF



Note

- Start code: Start of request
- Device address: Our product address
(ex. This is on the front panel in case of DMC10)
- Resister address: See the communication resister table of each product manual
- Word count: Number of resister you want to read (This is up to 16)
- Byte count: byte count = 2 x word count (This is up to 64)
- Resister value: Data you want to write
- LRC: Add from the character next to the start code to resister values together and complement it
- Delimiter: CR code
- Delimiter: LF code

● Structure of response

• Response of reading multiple registers

Start code	Device address	Function code	Byte count	Resister values	LRC	Delimiter	Delimiter
:	2chars	03 (hex.)	2chars	(2 x byte count) chars	2 chars	CR	LF



Note

- Start code: Start of request
- Device address: Product address you read
- Byte count: 2 x Number of resister you read
- Resister value: Data you read
- LRC: Add from the character next to the start code to resister values together and complement it
- Delimiter: CR code
- Delimiter: LF code

• Response of writing multiple registers

Start code	Device address	Function code	Resister address	Word count	LRC	Delimiter	Delimiter
:	2chars	10 (hex.)	4chars	4chars	2chars	CR	LF



Note

- Start code: Start of request
- Device address: Product address you wrote
- Resister address: Resister address you wrote
- Word count: Number of resister you wrote
- LRC: Add from the character next to the start code to resister values together and complement it
- Delimiter: CR code
- Delimiter: LF code

● **Structure of exception response**

- Exception response of reading multiple registers

Start code	Device address	Function code	Exception code	LRC	Delimiter	Delimiter
:	2chars	83 (hex.)	2chars	2chars	CR	LF

 **Note**

Start code: Start of request
 Device address: Product address you wrote
 Exception code: See table2.3
 LRC: Add from the character next to the start code to register values together and complement it
 Delimiter: CR code
 Delimiter: LF code

- Exception response of writing multiple registers

Start code	Device address	Function code	Exception code	CRC	Delimiter	Delimiter
:	2chars	90 (hex.)	2chars	2chars	CR	LF

 **Note**

Start code: Start of request
 Device address: Product address you wrote
 Exception code: See table2.3
 LRC: Add from the character next to the start code to register values together and complement it
 Delimiter: CR code
 Delimiter: LF code

Table 2.3: Exception code

Code	Contents	Cause
1	Illegal Function	Undefined function code
2	Illegal Data address	<ul style="list-style-type: none"> •Undefined data address •Undefined character code of data address
3	Illegal Data value	<ul style="list-style-type: none"> •Data range over Note:Go on writing except range over data •Undefined character code of data value Note: Go on reading or writing until undefined character code appeared

Chapter 12. ADJUSTMENT & ZENER BARRIER ADJUSTMENT

This chapter describes how to adjust the DMC10.

! Handling Precautions

Yamatake accepts no liability regarding trouble arising from wrongful adjustment of the DMC10 by the user.

The DMC10 can be restored to its original default adjusted state during the adjustment by selecting [Command]-[Restore Data] in the pull-down menu and discarding the adjustment data set so far. Note that all the adjustment settings made by the user so far will be lost if this procedure is performed mistakenly during adjustment.

■ Precautions before Adjustment

Observe the following during adjustment:

- Supply power to the DMC10 for at least one hour before starting the adjustment. Failure to do so might result in faulty accuracy.
- Make sure that the ambient temperature in which the DMC10 is adjusted conforms to the reference conditions stipulated in the DMC10's specifications. Failure to do so might result in faulty accuracy.
- Do not adjust the DMC10 in locations where it is subject to wind or ambient temperature fluctuations. Failure to do so might result in faulty accuracy.
- Do not adjust the DMC10 using equipment that fails to satisfy the specifications indicated in the item "■ Measurement Equipment Required for Adjustment" below. Failure to do so might result in faulty accuracy.

■ Measurement Equipment Required for Adjustment

Measuring Device	Specifications
Reference current/voltage generator	Accuracy $\pm 0.1\%$ or less, min. resolution $100\mu V$ or less (voltage) min. resolution $100\mu A$ or less (current)
Resistor	Accuracy $\pm 0.1\%$ or less, min. resolution 0.1Ω or less
Ammeter	Accuracy $\pm 0.1\%$ or less, min. resolution $1\mu A$ or less
Thermometer	Accuracy $\pm 0.1^\circ C$ or less, min. resolution $0.1^\circ C$ or less

■ Adjustment Procedure

● Inspecting each I/O

- (1) Select the [Inspect I/O] tab.
- (2) Select the desired item from among the inspection items.
- (3) Press the [Execute] key.

Inputs (external switch input, etc.) can be read continuously. So, cause an input at the input terminal of the DMC10, and display the ON/OFF state on the display. With outputs (event output, etc.), the setting (ON/OFF) marked in the checkbox is output to the output terminal of the DMC10.

● Adjusting PV input

! Handling Precautions

All gains must be adjusted when performing PV input adjustment.

- (1) Select the [Adjust PV Input] tab.
- (2) Select the target channel to be adjusted.
- (3) Select the gain starting from the smallest number, and adjust all gains. Start from gain number "01".
- (4) Select [Zero] at the zero span selection item.
This is because zero/span are in a set for each single gain item. Select the gain, be sure to execute [Zero] and then execute [Span].
- (5) Press the [Read] key.
- (6) Apply the zero applied voltage/current/resistance for the gain selected at the target customer terminal. For details on the connection method when applying these, refer to the following figures.

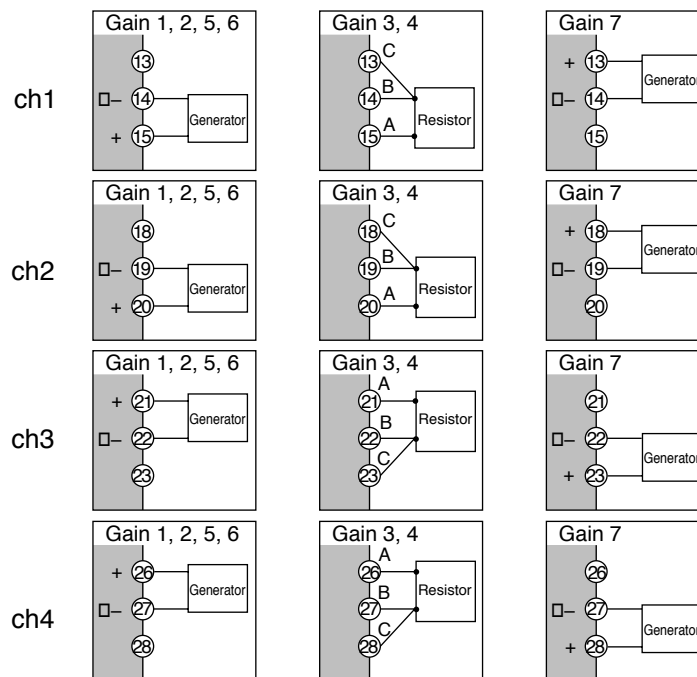

- (7) Hold the applied state for about 30 seconds. Note, however, that this is not the case when the terminal is left open for a long time before applying the above. For this reason, set the terminal to the 0V state (or short circuit across terminals) before applying the above.
- (8) Press the [Execute] key.
- (9) Return to the zero span selection at step (4), select [Span] and execute steps (5) to (8) on the span side. When the zero/span adjustment is completed for a single gain, proceed to the next step.
- (10) Return to the gain selection at step (3), move to the next higher gain number, and repeat steps (3) to (9).
- (11) When you have completed adjusting all gains within the selected channel, return to selection of the channel that you want to adjust as described in step (2), and repeat adjustment of the remaining channels following the same procedure as described above.

● **Adjusting cold junction compensation**

With this adjustment, leave the DMC10 for at least one hour with all I/Os in an OFF state.

Failure to do so might result in faulty adjustment of this item.

- (1) Select the [Adjust Terminal Temperature] tab.
- (2) Select the target channel to be adjusted.
- (3) Press the [Read] key.
- (4) Connect the thermometer to the terminal.
- (5) For details on the connection method, refer to the following figures.

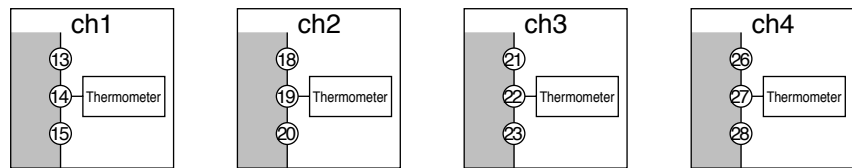

- (6) Make the connection, and wait for about five minutes.
- (7) Enter the thermometer value while the thermometer is indicating.
- (8) Press the [Execute] key.
- (9) Return to selection of the channel that you want to adjust as described, and repeat adjustment of the remaining channels following the same procedure as described above.

● **Adjusting wiring resistance**

- (1) Select the [Adjust Wiring Resistance] tab.
- (2) Select the target channel to be adjusted.
- (3) Select [Zero] at the zero span selection item.

This is because zero/span are in a set for a single channel. Select channel gain, be sure to execute [Zero] and then execute [Span].

- (4) Press the [Read] key.
- (5) Apply the zero resistance for the channel selected at the target customer terminal. For details on the connection method when applying these, refer to the following figures.

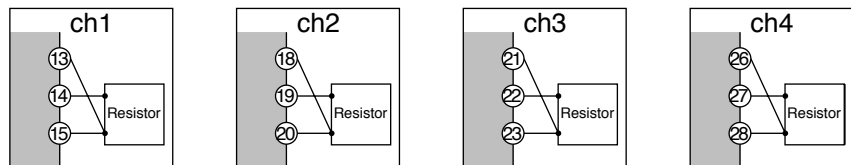

- (6) Hold the applied state for about 30 seconds.
Note, however, that this is not the case when the terminal is left open for a long time before applying the above. For this reason, set the terminal to the 0V state (or short circuit across terminals) before applying the above.
- (7) Press the [Write] key.
- (8) Return to the zero span selection at step (3), select [Span] and execute steps (5) to (8) on the span side. When the zero/span adjustment is completed for a single channel, proceed to the next step.

- (9) Return to selection of the channel that you want to adjust as described in step (2), and repeat adjustment of the remaining channels following the same procedure as described above.

● **Adjusting CT input**

- (1) Select the [Adjust CT Input] tab.
- (2) Select the target channel to be adjusted.
- (3) Select [Zero] at the zero span selection item.
This is because zero/span are in a set for each single channel. Select the channel, be sure to execute [Zero] and then execute [Span].
- (4) Press the [Read] key.
- (5) Apply the zero or span current value for the channel selected at the target customer terminal. For details on the connection method when applying this, refer to the following figures.
- (6) Hold the applied state for about 30 seconds.

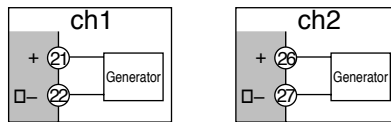

- (7) Press the [Write] key.
- (8) Return to the zero span selection at step (3), select [Span] and execute steps (5) to (8) on the span side. When the zero/span adjustment is completed for a single channel, proceed to the next step.
- (9) Return to selection of the channel that you want to adjust as described in step (2), and repeat adjustment of the remaining channels following the same procedure as described above.

● **Adjust AUX output**

- (1) Select the [Adjust Voltage Output] tab.
- (2) Select the target channel to be adjusted.
- (3) Select [Zero] at the zero span selection item.
This is because zero/span are in a set for each single channel. Select the channel, be sure to execute [Zero] and then execute [Span].
- (4) Press the [Read] key.
- (5) Apply the zero or span current value for the channel selected at the target customer terminal.
For details on the measurement method, refer to the following figures.

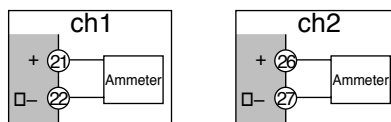

- (6) Hold the applied state for about 30 seconds.
- (7) Read the current on the ammeter in mA units down to three digits past the decimal point, enter the value on screen, and press the [Write] key.
- (8) Return to the zero span selection at step (3), select [Span] and execute steps (5) to (8) on the span side.
When the zero/span adjustment is completed for a single channel, proceed to the next step.
- (9) Return to selection of the channel that you want to adjust as described in step (2), and repeat adjustment of the remaining channels following the same procedure as described above.

■ About Zener Barrier Adjustment

When RTD input is combined with Zener barriers for use on the DMC10, the DMC10 must be adjusted to compensate for deviation in the resistance values of the Zener barriers.

Generally, the internal impedance of a Zener barrier is large. For this reason, use a Zener barrier that matches the allowable wiring resistance specifications of the resistance temperature detector.

Zener barriers made by Yamatake have an internal impedance of about 70Ω . So, they can be used in DMC10's ranges 21, 24, 27 or 28.

- (1) Wire as shown in the following figure.

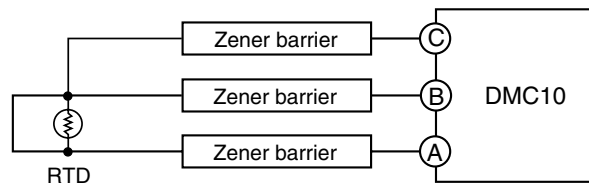

- (2) Select Zener barrier adjustment in [Setup Function]-[Setup] on SLP-D10.

! Handling Precautions

Zener barrier adjustment is performed at [Menu]-[Setup] on the loader. This adjustment item is not included in [Adjust].

- (3) Designate the PV channel to be adjusted.
- (4) Press the [Read] key.
- (5) Hold the applied state for about 30 seconds.
- (6) Press the [Write] key.
- (7) To continue adjusting another channel, repeat steps (3) to (6) of this procedure.

Chapter 13. TROUBLESHOOTING

Trouble is broadly classified into the following types:

- PV input related trouble
- Body alarms related trouble
- Loader communications related trouble
- Host communications related trouble
- Control related trouble

■ How to Use the LEDs on the Front Panel When Checking Alarms

The below types of operation can be assigned to the LEDs on the front panel of the DCM10 in the settings. Operation, for example, when an error occurs can be checked by the lit state of the LEDs.

In particular, regarding communications states, you can tell at a glance whether or not communications has been established.

Item	Description	Factory Setting
LED operation type	0: No function 1: Blinking in READY mode 2: Blinking in MANUAL mode 3: Blinking in RSP mode 4: Blinking at self-tuning correction standby 5: Blinking at execution of auto-tuning 6: Blinking at PV alarm occurrence 7: Blinking at memory alarm occurrence 8: SP set selection number blinking 9: Blinking during master communications * 1 10: Blinking during master/loader communications 11: MV relay state (lit when ON) 12: Event relay state (lit when ON) 13: External bus calculation result (lit when ON) 14: Physical DI input state (lit when ON) 15: External bus mode (lit when ON) 16: Communications DI input mode (lit when ON) 17: Blinking during inter-channel deviation control 18: Blinking during SP gradient time 19: Inference of motor control position in progress	0: No function

* 1 Blinks when reception is successful at the self device address.

■ PV Input Related Trouble

The following table shows PV input related trouble:

Description of Fault	Cause	Remedy
<ul style="list-style-type: none"> Indicated value is out of range. PV upper limit or PV lower limit alarm occurred on loader. 	<ul style="list-style-type: none"> The sensor is not connected. In the case of a sensor that requires a power supply, appropriate power is not being supplied. Sensor fault is causing the input value to exceed the upper limit or lower limit values. The wiring to the sensor is broken. Terminal screws are loose. PV input terminals on unused channels are in an open state. The device is faulty. 	<ul style="list-style-type: none"> Connect the wiring to the sensor. Check if power is being supplied. If it is, check the voltage value. Check the sensor. Replace if faulty. Check the connector leads. Replace if abnormal. Tighten the screws. Short-circuit PV inputs on unused channels. Contact Yamatake or your Yamatake agent.
<ul style="list-style-type: none"> PV value fluctuates. 	<ul style="list-style-type: none"> The device is influenced by external noise. The control method is incorrect. The control constants are not appropriate values. The terminal screws are loose and are causing faulty contacts. The device is faulty. 	<ul style="list-style-type: none"> Adopt noise countermeasures. Change the control method. Perform auto-tuning. Manually enter the PID constants. Tighten the screws. Contact Yamatake or your Yamatake agent.
<ul style="list-style-type: none"> PV value stays fixed and does not change. 	<ul style="list-style-type: none"> The sensor is faulty. In the case of a sensor that requires a power supply, appropriate power is not being supplied. The device is faulty. (lit when ON) 	<ul style="list-style-type: none"> Check the sensor. Replace if faulty. Contact Yamatake or your Yamatake agent.

■ Body Alarms Related Trouble

The below table shows body alarms related trouble. If an error occurs, in many cases, the device body is malfunctioning, and repair or replacement is necessary. You can check at “Alarm” in the monitor mode on the loader which of the following trouble applies:

Description of Fault	Cause	Remedy
<ul style="list-style-type: none"> CJ (cold junction compensation function) error B line break state 	<ul style="list-style-type: none"> The cold junction compensation function is faulty. In the case of RTD input, the B line to the sensor is broken. 	<ul style="list-style-type: none"> Contact Yamatake or your Yamatake agent. Check the connector leads. Replace if abnormal.
<ul style="list-style-type: none"> A/D conversion function 	<ul style="list-style-type: none"> The A/D converter on the PV input section is faulty. 	<ul style="list-style-type: none"> Contact Yamatake or your Yamatake agent.
<ul style="list-style-type: none"> RAM parameter checksum error 	<ul style="list-style-type: none"> Noise or device fault is causing a checksum error in the RAM data. 	<ul style="list-style-type: none"> Turn the power OFF then back ON again. If this does not correct the problem, contact Yamatake or your Yamatake agent.
<ul style="list-style-type: none"> RAM adjustment checksum error 	<ul style="list-style-type: none"> Noise or device fault is causing a checksum error in the RAM data. 	<ul style="list-style-type: none"> Turn the power OFF then back ON again. If this does not correct the problem, contact Yamatake or your Yamatake agent.
<ul style="list-style-type: none"> EEPROM all areas checksum error 	<ul style="list-style-type: none"> Noise, etc. has damaged the data in EEPROM. 	<ul style="list-style-type: none"> Contact Yamatake or your Yamatake agent.

■ Loader Communications Related Trouble

Check the following if communications with the personal computer loader is not established via the loader jack on the front panel of the device:

Description of Fault	Cause	Remedy
<ul style="list-style-type: none"> • Writing to the DMC10 is not possible from the personal computer in the Setup screen. • Data cannot be uploaded to the DMC10 from the personal computer in the Setup screen. • The numerical monitor cannot be started in the Numerical Monitor screen. • The trend monitor cannot be started in the Trend Monitor screen. • Data cannot be read in the Adjust screen. 	<ul style="list-style-type: none"> • The loader cable is not correctly inserted into the front panel port on the DMC10. • The loader cable is not inserted into the correct communications port on the personal computer. • The authorised cable is not used. • A break or other abnormality has occurred on the cable. • The setting of the loader's communications port is in error. • Appropriate power is not being supplied to the DMC10. 	<ul style="list-style-type: none"> • Check the wiring state of the loader cable. • Check the communications port of the personal computer to which the loader cable is currently connected. • Check the settings of the loader's communications port. • Replace the cable. • Make sure that appropriate power is being supplied to the DMC10.

■ Host Communications Related Trouble

Check the following if communications with the personal computer, PLC or other host device is not established by the RS-485 communications functions on the device body:

Description of Fault	Cause	Remedy
<ul style="list-style-type: none"> • No response in communications 	<ul style="list-style-type: none"> • Wiring is not performed to the correct terminals. • A break has occurred in the wiring. • The screws are loose. • The address setting for the DMC10 is in error. • The transmission speed does not match the device setting. • The communications conditions do not match the device setting. • The device address of the send message is in error. • The format of the send message is in error. • The send message contains a checksum whose content is in error. • The terminating resistor is used. • Communications timing is not correct. 	<ul style="list-style-type: none"> • Wire to the correct terminals. • Replace the connector lead. • Tighten the screws. • Correctly set the address on the front panel on the DMC10. • Check the transmission speed on the personal computer loader, and correct the settings. • Check the communications conditions on the personal computer loader, and correct the settings. • Correct the device address of the send message. • Correct the format of the send message. • Check and correct the content of the checksum. • Remove the terminating resistor. <p>See “10-7 Reception and Transmission Timing” (page 10-15).</p>
<ul style="list-style-type: none"> • A communications response indicating an error content has been returned. 	<p>The send message is in error.</p>	<p>See “10-6 List of Status Codes” (page 10-14).</p>

■ Control Related Trouble

The below table shows control related trouble. Note, however, that it is sometimes difficult to alleviate these troubles by measures performed only on the control device due to the characteristics of the control device or the structure of the instrumentation.

Description of Fault	Cause	Remedy
<ul style="list-style-type: none"> It takes a long time to start up. 	<ul style="list-style-type: none"> Suitable control constants are not being input. The startup time of the control target itself is long. Self-tuning and interference or intermittent disturbance is causing PID constants to be extremely large values. 	<ul style="list-style-type: none"> Start up auto-tuning. Increase the capabilities of the control device. Set the PID values to their defaults, and either set the control method to "control by PID fixed values", or set the self-tuning correction width to "0".
<ul style="list-style-type: none"> The PV value is unstable. 	<ul style="list-style-type: none"> Suitable control constants are not being input. 	<ul style="list-style-type: none"> Start up auto-tuning.
<ul style="list-style-type: none"> Overshoot at startup is large. 	<ul style="list-style-type: none"> Suitable control constants are not being input. 	<ul style="list-style-type: none"> Start up auto-tuning.
<ul style="list-style-type: none"> Tuning does not end. 	<ul style="list-style-type: none"> Minute fluctuations in the PV value do not come to a stop. 	<ul style="list-style-type: none"> Set the value of the PV filter to about 1 or 2 seconds.*
<ul style="list-style-type: none"> Control signals repeatedly turn ON and OFF more than necessary. 	<ul style="list-style-type: none"> The time proportional cycle is short. Control output values are fluctuating excessively. The differential is large in ON/OFF control. 	<ul style="list-style-type: none"> Increase the time proportional cycle.* Change the "time proportional operating mode" setting to "priority on control device life."** Increase the differential value.* Set the value of the PV filter to about 1 or 2 seconds.*

* Note that controllability sometimes drops when these remedies are performed.

Chapter 14. SPECIFICATIONS

14 - 1 General Specifications

■ Environmental Conditions

Conditions	Item	Specifications	
Reference conditions	Ambient temperature	23±2°C	
	Ambient humidity	60±5%RH (condensation not allowed)	
	Power voltage	24Vdc±5%	
	Vibration resistance	0m/s ²	
	Impact resistance	0m/s ²	
	Mounting angle	(reference plane) ±3°	
Operating conditions	Ambient temperature	0 to 50°C	
	Ambient humidity	10 to 90%RH (condensation not allowed)	
	Rated power voltage	24Vdc	
	Permissible operating power voltage	24Vdc±10%	
	Vibration resistance	0 to 1.96m/s ² (10 to 60Hz, for 2h in each of XYZ axes)	
	Impact resistance	0 to 9.81m/s ² (3 times)	
	Mounting angle	(reference plane) ±10°	
Transport/storage conditions	Ambient temperature	-20 to +70°C	
	Ambient humidity	10 to 95%RH (condensation not allowed)	
	Vibration resistance	0 to 4.90m/s ² (10 to 60Hz, for 2h in each of XYZ axes)	
	Impact resistance	0 to 196m/s ² (DIN rail-mounted state, 3 times in vertical direction) 0 to 392m/s ² (wall-mounted state, 3 times in vertical direction)	
	Package drop test	Drop height 60cm (free fall on 1 corner, 3 sides, 6 planes)	
Other specifications	Memorization system	Non-volatile memory	
	Insulation resistance	Min. 20MΩ Across power terminal and secondary terminal (by 500Vdc insulation testing set)	
	Dielectric strength	500Vac, 1min Across power terminal and secondary terminal/case	
	Power consumption	DMC10S/DMC10D types: Max. 5W (under operating conditions) DMC10E type: Max. 3W (under operating conditions)	
	Rush current at power ON	Max. 10A (under operating conditions)	
	Case material, color	Polycarbonate resin, light gray	
	Mounting method	DIN rail or screws	
	Screw tightening torque	Base M3.5 screw	0.8 to 1.0 N·m
		Terminal wiring model	M3.5 screw 0.8 to 1.0 N·m
		Connector wiring model	Connector terminal 0.5 to 0.6N·m Connector mount 0.5 to 0.6N·m
	Mass	Max. 200g	
External dimensions	30 x 100 x 110mm (For details, see external dimension drawings.)		

14 - 2 Performance Specifications

■ PV Input

Conditions	Specifications				
Input type	Thermocouple K, J, E, T, R, S, B : JIS C 1602-1995 DIN U, DIN L : DIN43710-1985 PLII : Engelhard Industries documents(IPTS68) RTD Pt100 : JIS C 1604-1997 JPt : JIS C 1604-1989 Linear (DC current) 4 to 20mA Linear (DC voltage) 1 to 5V, 0 to 5V, 0 to 1V				
Input sampling cycle	500ms				
Indication accuracy	<table style="width:100%; border:none;"> <tr> <td style="width:50%; text-align:center;">DMC10S</td> <td style="width:50%; text-align:center;">DMC10D</td> </tr> <tr> <td>±0.5%FS ±1 digit The negative area of the thermocouple ±1.0%FS ±1 digit For the thermocouple B Under 260°C ±5.0%FS ±1U 260 to 800°C ±2.0%FS ±1U 800 to 1800°C ±1.0%FS ±1U</td> <td>±0.3%FS +/-1 digit The negative area of the thermocouple ±0.6%FS ±1 digit For the thermocouple B Under 260°C ±-5.0%FS ±1U 260 to 800°C ±1.0%FS ±1U 800 to 1800°C ±0.5%FS ±1U</td> </tr> </table>	DMC10S	DMC10D	±0.5%FS ±1 digit The negative area of the thermocouple ±1.0%FS ±1 digit For the thermocouple B Under 260°C ±5.0%FS ±1U 260 to 800°C ±2.0%FS ±1U 800 to 1800°C ±1.0%FS ±1U	±0.3%FS +/-1 digit The negative area of the thermocouple ±0.6%FS ±1 digit For the thermocouple B Under 260°C ±-5.0%FS ±1U 260 to 800°C ±1.0%FS ±1U 800 to 1800°C ±0.5%FS ±1U
DMC10S	DMC10D				
±0.5%FS ±1 digit The negative area of the thermocouple ±1.0%FS ±1 digit For the thermocouple B Under 260°C ±5.0%FS ±1U 260 to 800°C ±2.0%FS ±1U 800 to 1800°C ±1.0%FS ±1U	±0.3%FS +/-1 digit The negative area of the thermocouple ±0.6%FS ±1 digit For the thermocouple B Under 260°C ±-5.0%FS ±1U 260 to 800°C ±1.0%FS ±1U 800 to 1800°C ±0.5%FS ±1U				
Input bias current	<ul style="list-style-type: none"> •Thermocouple: Max. 0.2μA (under reference conditions) •RTD: Approx. 1mA, current flowing from A terminal •Linear: Max. 5μA (under reference conditions) 				
Allowable wiring resistance	<ul style="list-style-type: none"> •Thermocouple: Max. 250Ω (total of all leads) •RTD (range 21, 24, 27, 28): Max. 80Ω (per lead) •RTD (range 22, 23, 25, 26, 29, 30, 31, 32, 33, 34): Max. 10Ω (per lead) •Linear: Max. 250Ω (total of all leads) 				
Influence of wiring resistance	<ul style="list-style-type: none"> •Thermocouple: Max. ±0.2μV/Ω •RTD: Max. ±0.05%FS/Ω •Linear: Max. ±5μV/Ω 				
Input impedance	Max. 120Ω (4 to 20mA input range)				
Allowable input Voltage	Max. 4V (a higher voltage might cause device failure)				

● Operation at a thermocouple input line break

Break Circumstances	Movement of PV Value	Alarm Indication	Control Output	Event Output
Thermocouple break	Up scale	Upper limit alarm	According to setting	Operation continued*

*: Can be changed by setting.

● Operation at an RTD input line break (BC line alarm occurs when allowable wiring resistance is exceeded.)

Break/Short-circuit Circumstances	Movement of PV Value	Alarm Indication	Control Output	Event Output
Register break	Up scale	Upper limit alarm	According to setting	Operation continued*1
A line break	Up scale	Upper limit alarm	According to setting	Operation continued*1
B line break	Up scale	Upper limit alarm, BC line alarm	According to setting	Operation continued*1
C line break	Down scale	Lower limit alarm, BC line alarm	According to setting	Operation continued*1
2 or more lines break	Up scale	Upper limit alarm, BC line alarm	According to setting	Operation continued*1
A, B lines short-circuited	Down scale*2	Lower limit alarm*2	According to setting	Operation continued*1
A, C lines short-circuited	Down scale*2	Lower limit alarm *2	According to setting	Operation continued*1

*1: Can be changed by setting.

*2: Ranges 21 and 24 cannot be detected.

● Operation at a linear input line break

Break Circumstances	Movement of PV Value	Alarm Indication	Control Output	Event Output
Voltage range break	Up scale	Upper limit alarm	According to setting	Operation continued*
Current range break	Down scale	Lower limit alarm	According to setting	Operation continued*

* Can be changed by setting.

● **Action at the time of feedback input line break**

Break Circumstances	Behavior of Position Proportional Control	Alarm Indication	Control Output
T line break	When the position proportional control type of 1 is used, the inferred position control is used.	T line break alarm	No change
Y line break		Y line break alarm	No change
G line break		G line break alarm	No change

● **Unused channel range table**

When there is an unused channel, control output and PV alarm output turn OFF by setting to the range Nos. in the following table: PV input processing to unused channels is not required.

Range No.	Specifications
00	PV value: Fixed at 0°C, control output: OFF, PV alarm: OFF

● **Thermocouple PV input type/range table**

Range No.	Sensor Symbol	Temperature Range (°C)	Min. Resolution (°C)
01	K:CA	0 to 1200	1
02	K:CA	0 to 600	1
03	K:CA	0 to 400	1 *
04	K:CA	-200 to +400	1 *
05	J:IC	0 to 800	1
06	J:IC	-200 to +400	1 *
07	E:CRC	0 to 600	1
08	T:CC	-200 to +400	1 *
09	DINU	-200 to +400	1 *
10	DINL	0 to 800	1
11	R	0 to 1600	1
12	S	0 to 1600	1
13	PLII	0 to 1200	1
14	B	0 to 1800	1

* : The minimum resolution of these ranges is 1, 0.1°C only on the advanced model DMC10D.

● **RTD PV input type/range table**

Range No.	Sensor Symbol	Temperature Range (°C)	Min. Resolution (°C)
21	Pt100	-200 to +500	1
22	Pt100	0 to 200	1, 0.1
23	Pt100	-50 to +100	1, 0.1
24	JPt100	-200 to +500	1
25	JPt100	0 to 200	1, 0.1
26	JPt100	-50 to +100	1, 0.1
27	Pt100	-100 to +300	1
28	JPt100	-100 to +300	1
29	Pt100	-50 to +150	1, 0.1
30	JPt100	-50 to +150	1, 0.1
31	Pt100	-75 to +175	1, 0.1
32	JPt100	-75 to +175	1, 0.1
33	Pt100	-100 to +200	1, 0.1
34	JPt100	-100 to +200	1, 0.1

● **Linear input PV input type/range table**

Range No.	Sensor Symbol	Input Range	Programmable Range	Min. Resolution (°C)
41	4-20mA	4 to 20mA	-2000 to +10000	1, 0.1, 0.01, 0.001
42	1-5V	1 to 5V	-2000 to +10000	1, 0.1, 0.01, 0.001
43	0-5V	0 to 5V	-2000 to +10000	1, 0.1, 0.01, 0.001
44	0-1V	0 to 1V	-2000 to +10000	1, 0.1, 0.01, 0.001

● Control output

Conditions	Item	Specifications	
Relay output	Control method	ON/OFF, time-proportional PID	
	Output type	Relay output	
	Contact configuration	1a (SPST, Normally Open)	
	Contact rating	3A (30Vdc/250Vac, resistive load)	
	Life	100,000 operations or more	
	Min. switching voltage/current	5V, 100mA	
	Time proportional output resolution	1/1000	
	Time proportional output cycle	5s to 120s (set in 1s increments)	
	Updating of time proportional output	Select the following in the setup: <ul style="list-style-type: none"> • Output turns ON/OFF tracked to changes in the OUT value that occur within the time proportional output cycle. • Output turns ON once within the time proportional output cycle. 	
Voltage output (V)	Control method	ON/OFF, time-proportional PID	
	Output type	Voltage drive system	
	Internal resistance	150Ω±5%	
	Open terminal voltage	13Vdc±5%	
	Load current	Max. 30mA Note: Care is required to prevent the device from being reset by actuation of the overcurrent protection function in the internal power supply circuit when output is short-circuited.	
	OFF leakage current	Max. 100μA	
	Time proportional output resolution	1/1000	
	Time proportional output cycle	1s to 120s (set in 1s increments)	
	Updating of time proportional output	Select the following in the setup: <ul style="list-style-type: none"> • Output turns ON/OFF tracked to changes in the OUT value that occur within the time proportional output cycle. • Output turns ON once within the time proportional output cycle. 	
Event output (DMC10S, DMC10D model)	Number of points	2 or 4	
	Output type	Relay contact output	Voltage output
	Output rating	Contact type: SPST Contact rating: 250Vac, 1A 30Vdc, 1A Life: 100,000 operations or more (resistive load) Min. switching specification: 5V, 10mA	Open voltage: 13Vdc±5% Internal resistance: 150Ω±5 OFF leakage current: Max. 100μA Output current: Max. 30mA
Auxiliary output (AUX)	Output type	0 to 20mAdc or 4 to 20mAdc, Selectable in the setup	
	Allowable load resistance	Max. 510Ω	
	Output resolution	Min. 1/10000	
	Output content	PV, SP, MV, inter-channel	
	Output updating cycle	500ms	
	Output accuracy	DMC10S: ±0.5%FS (under reference conditions) DMC10D: ±0.3%FS (under reference conditions) Note: however, that 1mAdc or less is outside the guaranteed accuracy.	
Event output (DMC10E model)	Number of outputs	4	
	Output type	Relay output	
	Contact configuration (EV2, 4) (EV1, 3)	1a (SPST, Normally Open) 1c (SPDT, Normally Open & Normally Closed)	
	Contact rating	1A 30Vdc/250Vac (resistive load)	
	Life	100,000 operations or more (30 operation/min)	
	Min. switching voltage/current	5V, 10mA	

Conditions	Item	Specifications
External switch input	Number of inputs	2 or 4
	Input sampling time	100ms
	Min. detection hold time	Min. 100ms
	Parallel connection with other devices	Can be connected in parallel directly with SDC10/SDC40. For details on other devices, consult a Yamatake sales agent.
	Connectable output type	No-voltage contact or open-collector
	Open terminal voltage	13Vdc±10%
	Terminal current (short-circuit)	Current flowing from terminal: 5mA (typ.) (under operating conditions)
	Allowable ON contact resistance	Max. 250Ω (under operating conditions)
	Allowable OFF contact resistance	Min. 100kΩ (under operating conditions)
	Allowable ON residual voltage	Max. 2V (under operating conditions)
Current transformer input	Allowable OFF leak current	Max. 100μA (under operating conditions)
	Current transformer used	Sold separately QN206A (hole dia.: 5.8mm), QN212A (hole dia.: 12mm)
	Measurement current range	0.4 to 50.0A
	Indication accuracy	±5%FS
	Reception resistance	Approx. 50Ω
	Indication resolution	0.1A
Host communications	Input sampling cycle	100ms
	Signal level	RS-485-compliant
	Transmission path connection	Multi-point (max. 31 units per single host)
	Communications system	Half-duplex
	Synchronization	Start-stop synchronization
	Transmission control	Polling/selecting
	Max. line length	Max. 500m
	Number of communications lines	3-lead system
	Transmission speed error	Max. 0.16%
	Terminator	Terminator having equivalent terminal resistance built-in. So, external terminator cannot be used.
	Transmission speed	2400, 4800, 9600, 19200bps
	Data length	8bits
	Stop bit	1 or 2bits
Parity bit	Even parity or no parity	

■ Isolation between Inputs and Outputs

The following figure shows the mutual isolation between inputs and outputs:

PV CH1	Power supply	OUT CH1 *
PV CH2		OUT CH2 *
PV CH3		OUT CH3 *
PV CH4		OUT CH4 *
RSW CH1		EVENT CH1
RSW CH2		EVENT CH2
RSW CH3		EVENT CH3*
RSW CH4		EVENT CH4*
CT CH1	Logic	AUX CH1
CT CH2		AUX CH2
Loader communications		CPL communications

*: When a voltage output type is selected, the power supply is not isolated.

—: Isolated

---: Not isolated

■ External Dimensions

● DMC10S

Unit: mm

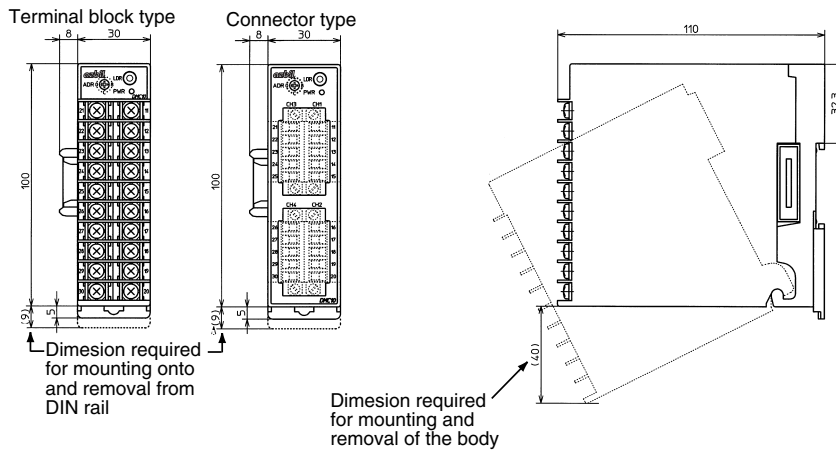

● DMC10E

Unit: mm

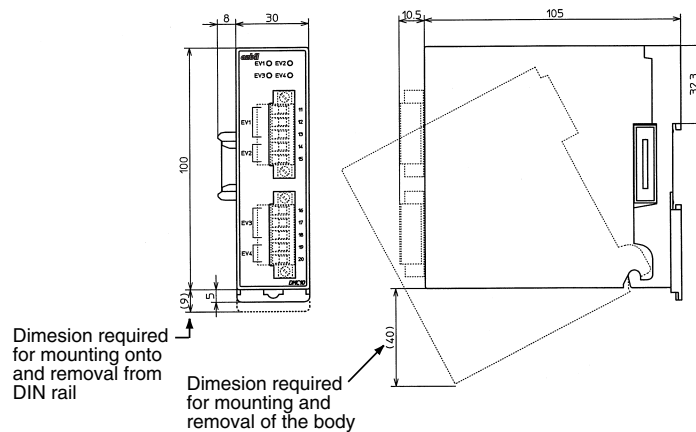

Appendix

1. Advice on Control Constants

The DMC10 has the following three control methods:

- ON/OFF control
- Control by self-tuning
- Control by PID fixed values

These control methods and related parameters are set at [Standard]-[Control Output] or [SP, Control].

■ ON/OFF Control

This is the simplest control method. Though setting and operation is simple, controllability is worse than other control methods. The following settings are required for performing ON/OFF control.

- Differential
This is the setting for the difference between the ON point and OFF point. This setting is for avoiding frequent ON/OFF operation of the control device. A large differential setting prevents frequent ON/OFF operation of the control device, though controllability decreases. Alternatively, a small differential setting increases controllability whereas the control device frequently turns ON and OFF.
- SP value

■ Control by Self-tuning

“Self-tuning” is a function for starting PID tuning automatically on the controller when the following operations are performed. Self-tuning frees the user from the trouble of setting the PID constants even if the characteristics of the control target fluctuate due to changing of the SP or work.

- When the SP (set point) has changed 5% or more of full scale (10% or more of full scale at initial startup when the control method has been set to “control by self-tuning”)
- When a deviation of the parameter self-tuning correction width or more has occurred during control

Handling Precautions

“ Full scale” refers to the full extent of the range on the controller.

[Example] In the case of K thermocouple input of -200 to $+400^{\circ}\text{C}$
Full scale is 600°C and 10%FS is 60°C .

- “Control by self-tuning” is PID time proportional control combined with automatic tuning of the PID constants by self-tuning.
- The more times that tuning is repeated, the more controllability of self-tuning improves. We recommend combined use of self-tuning with auto-tuning when calculating satisfactory controllability from when the DMC10 starts to run.

The following settings and operations are required for performing self-tuning:

1. Setting of the control method
2. Self-tuning correction width
3. Self-tuning up/down startup condition
4. Time proportional cycle
5. Time proportional control operation mode (when necessary)
6. Auto-tuning startup (when calculating a satisfactory controllability from initial running)

● Description of related setting items

- Self-tuning correction width
Of the self-tuning startup conditions, this is the startup condition width of self-tuning that is started up by occurrence of deviation. Self-tuning is started up when a deviation that exceeds this width occurs. When correction is set to “0”, self-tuning by deviation does not start up. Only startup by SP change is performed.
- Self-tuning up/down startup condition
Set this parameter when setting startup only at PV rise (change of SP value in up direction) during self-tuning by SP change. Normally, setup is performed when the PV both rises and falls (change of SP value in down direction). However, the control characteristics are markedly different during PV rise and fall, and the setting is changed when controllability during PV fall is not required. (We recommend this setting, for example, when controlling an injection molding machine having high heat retaining properties.)

! Handling Precautions

- Self-tuning is not active at all times; it is active only when SP changes or when a deviation of fixed value or more (self-tuning correction width or more) occurs. In other states, control is performed using already determined control constants.
- If the power is turned OFF while self-tuning has started up, the tuning result is not written to the controller. Whether or not self-tuning has ended can be verified on the PC loader’s monitor screen.
- Of the self-tuning startup conditions, tuning that is started up on deviation is not suitable for the following control targets:
 - Control targets that are adjacent to each other (up and down, left and right) such as reflow chambers, dies and injection molding machines and that are each influenced by fluctuations in PV
 - Machinery that intermittently causes disturbance such as packing machines.
In this case, set the self-tuning correction width to “ 0”. This disables startup by self-tuning due to occurrence of deviation. Self-tuning is started up only when the SP changes.

■ Control by PID Fixed Values

This function allows the user to set PID values for control constants manually or by auto-tuning for performing control. Once control constants have been set, they do not change as long as manual setting or auto-tuning is not performed.

We recommend this control method in the following instances:

- when the characteristics of the control target do not change even if the SP value or work is changed
- when disturbance in control due to fluctuation of these is no problem

The following settings are required for performing control by PID fixed value:

- Setting of the control method
- Setting of PID values, or startup of auto-tuning



Note

For details on the [disturbance response control \(Quick-FiTTER\)](#), see page 8-13. This parameter is for suppressing overshoot when PV changes from down to up on control targets whose temperature repeatedly fluctuates in a fixed pattern.

2. Advice on Events

● Buses

The side connector is the terminal standardly provided on the back of DMC10 for linking multiple units side by side.

The side connector contains: (1) power supply, (2) RS-485 line, (3) data bus input for On/Off signal X 4, and (4) data bus output for On/Off signal X 4. Only connecting via these connectors allows two or more number of DMC10 units the mutual use of these functions.

This chapter describes the bus for On/Off signal.

● Purpose of the bus signal transmitted via the side connector (On/Off signal transmission)

This signal is used to notify the On/Off status of a specific DMC10 unit to other DMC units or event modules. This function is useful when two or more number of DMC10 units are used together.

● Specifications for the bus signal transmitted via the side connector (On/Off signal transmission)

In the DMC10 units connected via side connectors, the On/Off signal buses are ORed.

Accordingly, if the bus output of any one instrument becomes ON, the inputs to all the instruments are turned ON and finally the corresponding output relay of the event module is turned ON.

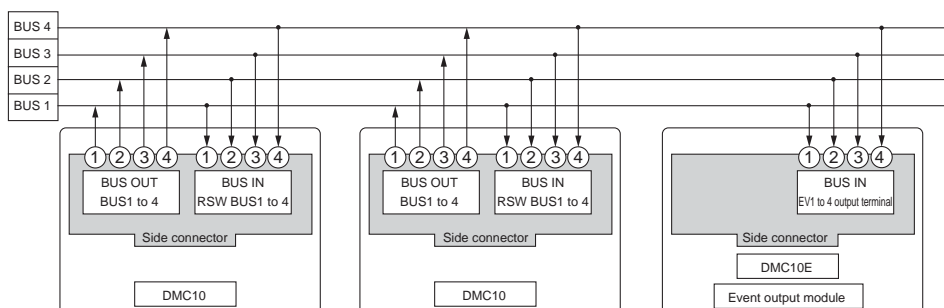

● Data transmittable via side connectors (On/Off signal transmission)

See the sections following on the event output operation and event input operation:

● Preparation for use of bus signals transmitted via side connectors (On/Off signal transmission)

The minimum settings to use this bus among two or more number of DMC10 units are as follows:

1. Defining the signal output to the bus from each instrument
 - Select "Event Special" on the "Special Function" screen of the loader.
 - The "Event Assign" of loader will be additionally displayed in the menu. In its settings, set the following items as required:
 - (a) Selecting the data to be output (multiple data items can be specified) ... "Output Assign1" to "Output Assign3"
 - (b) AND/OR operation of selected items ... "Logic"
 - (c) Latching the results ... "Latch"
 - (d) Selecting the direct/reverse action ... "Polarity"

2. Defining the processing of each instrument after receiving a signal from the bus- Select "RSW Special" on the "Special Function" screen of the loader.
 - The menu for "RSW input" of loader will be expanded. Set as required.
 - (a) Selecting the function to operate the DMC10 for the states of buses 1 to 4 ... "RSW type"
 - (b) Selecting the PV channel to operate ... "Channel"
 - (c) Selecting the On/Off status to be used ... "Input Assign1" to "Input Assign3"
 - (d) OR/AND operation of input status ... "Logic"
 - (e) Reversing the input status ... "Polarity"

For details, see "Event output special operation" and "External switch input special operation" on the following sections.

● **Device configuration and number of unit limitations**

Only one event output module DMC10E can be used in a linked group. When groups are wired from the base and not linked by the side connector as shown in the figure below, each group becomes an independent group, and a new DMC10E module can be used in that group.

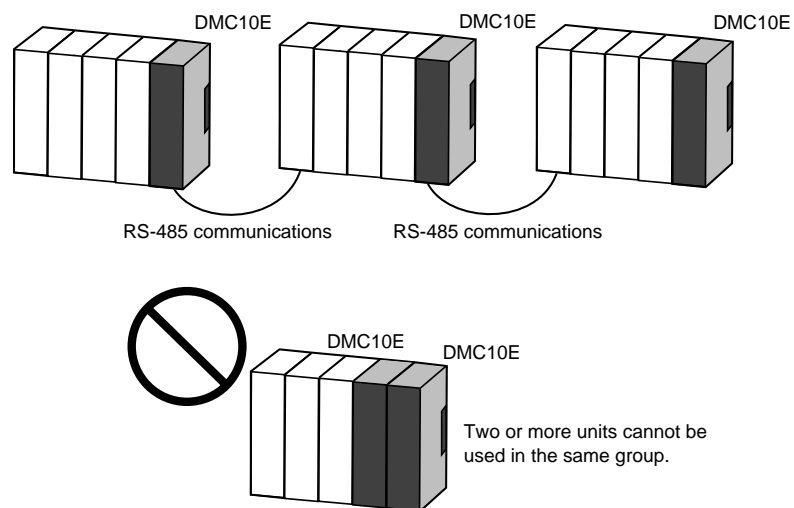

● **Assignment of event bus outputs to D/I**

Event bus outputs can be assigned to D/I internally as they are.

[Example]

Switching from the RUN mode to the READY mode when a heater line break occurs is possible without outputting that change in state.

How to set "Event assign" and "RSW Input" on the loader

In the basic function setup, the channel number is displayed on the horizontal axis on the loader screen. However, by "Event Assign" and "RSW Input", the event output number (event bus output number) or external switch input number are displayed on the horizontal axis.

3. Event Output Special Operation

■ Internal Structure of Event Output Special Operation

● Normal status

Normally, the action is set so that the results of operation for one event factor (one event table X 8) are simply output to one fixed output port.

Output destination terminal name (total of 12 terminals)	Internal factor to be output (Factory settings)	Remarks
Event terminal 1 (models with an event terminal only)	Results of EV1	Available for models with an event terminal only
Event terminal 2 (models with an event terminal only)	Results of EV2	
Event terminal 3 (models with an event terminal only)	Results of EV3	
Event terminal 4 (models with an event terminal only)	Results of EV4	
BUS1 (side connector)	Results of EV BUS1	Side connector bus output
BUS2 (side connector)	Results of EV BUS2	
BUS3 (side connector)	Results of EV BUS3	
BUS4 (side connector)	Results of EV BUS4	
OUT1	Results of time proportional output operation (PVch1)	-
OUT2	Results of time proportional output operation (PVch2)	
OUT3	Results of time proportional output operation (PVch3)	4-channel models only
OUT4	Results of time proportional output operation (PVch4)	

● When the event output special operation is used

By performing "various settings and operations for factor output" for each output destination terminal, it is possible to freely select and perform operations on the data to be output to the output terminals and side connector buses (total of 12 terminals).

Output destination terminal name (total of 12 terminals)	Various settings for output the factors via each of 12 terminals
Event terminal 1 (models with an event terminal only)	<input type="radio"/> <u>Factor selection (Multiple items selectable from among the following 40 types/factors)</u> <ul style="list-style-type: none"> • EV TBLs 1 to 8 • Event terminal outputs 1 to 4 • RSWs 1 to 4 • OUT 1 to 4 internal computation results • RSW TBL 1 to 8 internal computation results • RSW bus inputs 1 to 4 • Communications DI1 to DI12 <input type="radio"/> <u>Logic (0: OR 1: AND)</u> <input type="radio"/> <u>Polarity (0: Direct 1: Reverse)</u> <input type="radio"/> <u>Latch (0: OFF 1: ON(latch in ON) 2: ON(latch in OFF))</u> <input type="radio"/> <u>External bus type definitions (0: relay 1: voltage/pulse), see page 8-30</u>
Event terminal 2 (models with an event terminal only)	
Event terminal 3 (models with an event terminal only)	
Event terminal 4 (models with an event terminal only)	
BUS1 (side connector)	
BUS2 (side connector)	
BUS3 (side connector)	
BUS4 (side connector)	
OUT1	
OUT2	
OUT3	
OUT4	

- The following are the outline of each factor:

The types (factors) of output available states (total of 40 types)	Descripton
EV TBL (event table) 1 to 8	The results of internal computation on the event tables 1 to 8. This is the state of internal computation results before output to the terminal. The factor of event table uses the results computed with the following parameters. <ul style="list-style-type: none"> Event type, channel, polarity, standby, alarm OR action, event setting value (main, sub), hysteresis, event action at Ready, ON delay, OFF delay
Event terminal outputs 1 to 4	Output state of event terminal. Available for models with an event terminal only
RSWs 1 to 4	States of RSWs 1 to 4. Available for models with an optional RSW only.
OUT 1 to 4 computation results	Computation results of time proportional output. This is the internal state before output to the terminal.
RSW TBLs 1 to 8 internal computation results	The states set and used on the RSW TBLs 1 to 8. The factor of RSW table uses the results computed with the following parameters. <ul style="list-style-type: none"> RSW type, channel, logic, polarity
RSW bus inputs 1 to 4	The state of side connector bus input signal.
Communications DI1 to DI12	Bit state freely turned On/Off by being written through communications.

- Every model is standardly equipped with 8 event tables including those without event terminals. Consequently, it is possible to set up to 8 event states individually and output them via the side connector bus or read the event states through communications.

■ Block Diagram of Output Special Operation

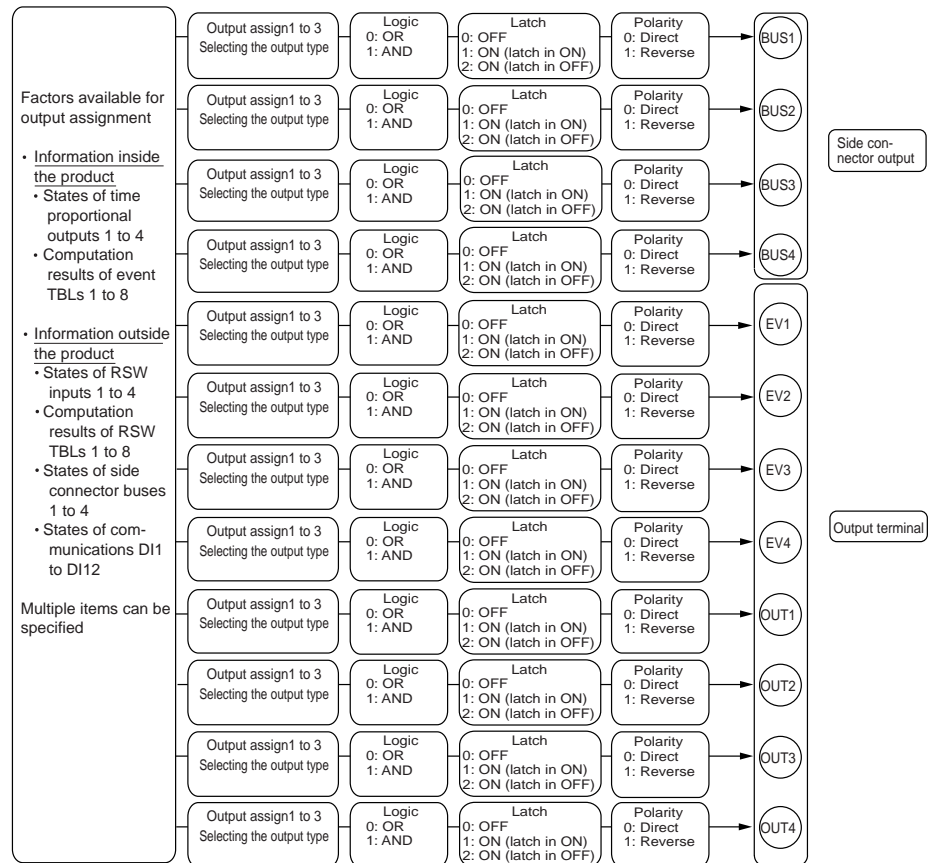

■ Operating Procedures for Event Output Special Operation

To use an event output special operation, follow the procedures below. Event output special operations do not operate without these settings.

The main steps are:

- (1) Specify the use of event output special operation
- (2) Set up the contents of the event action (event table)
- (3) Set up the event table output destination and logical action

Detailed procedures are described below.

● Setting procedures

- (1) Specify the use of event output special operation

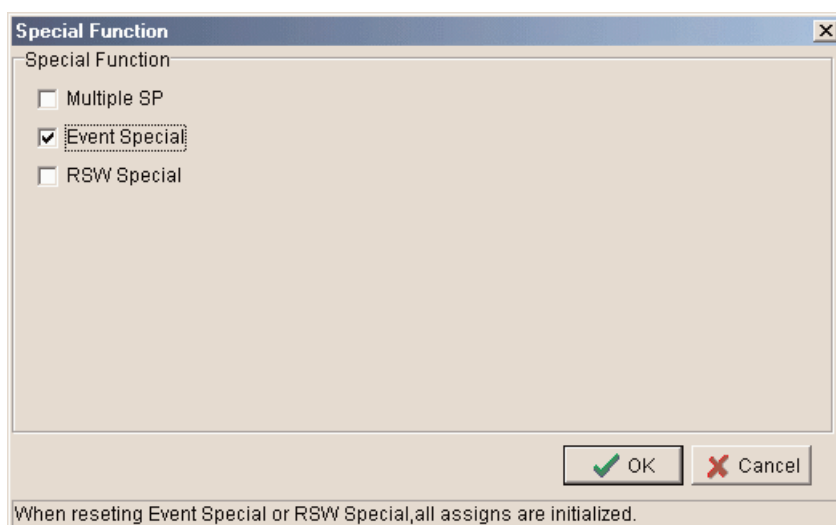

In the PC loader, select [Setup] → [Special Function], then check [Event Special] in the Special Function window.

The [Event Table] and [Event assign] items will appear under [Option] for setting event details and assigning the output destination.

The separate window for event setting is called an [Event Table].

- (2) Set up the event table

Select [Option] → [Event Table] to open an event table as shown below and set up the contents of the event action. Up to 8 event tables (from EV_TBL1 to EV_TBL8) are available.

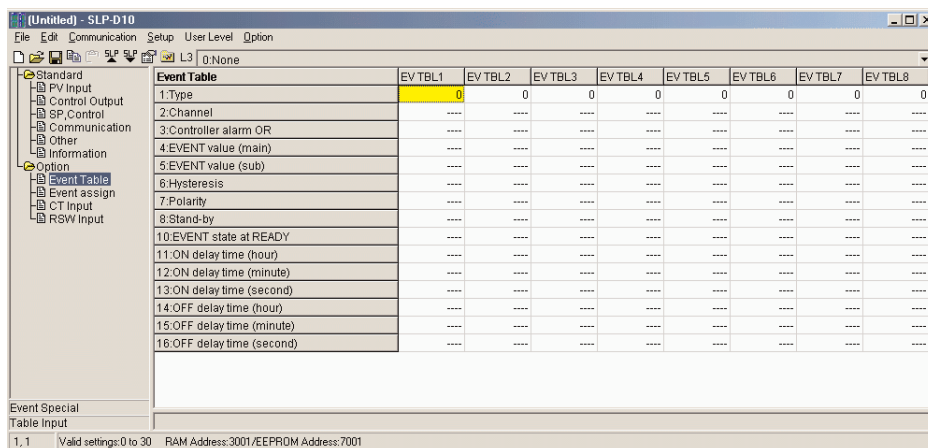

(3) Set up the event table output destination and logical action

Select [Option] → [Event assign] and set up the output destination of the set event table and the logical action.

1) Output destination

The names of the output destinations are displayed along the horizontal axis of the screen. They include EV1, EV2, EV3, EV4, EV_BUS1, EV_BUS2, EV_BUS3, EV_BUS4, OUT1, OUT2, OUT3 and OUT4 (some of these may be unavailable for some DMC10 models).

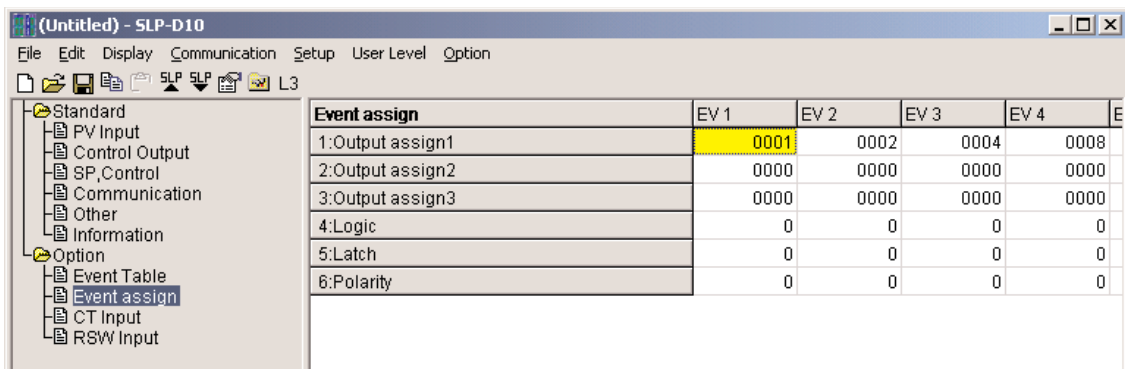

2) Assigning the setup contents

With the cursor placed in the Output assign1 or Output assign2 row, select [Edit] → [Bit edit] and the following window will appear.

- Setup window with the cursor placed in the Output assign1 row

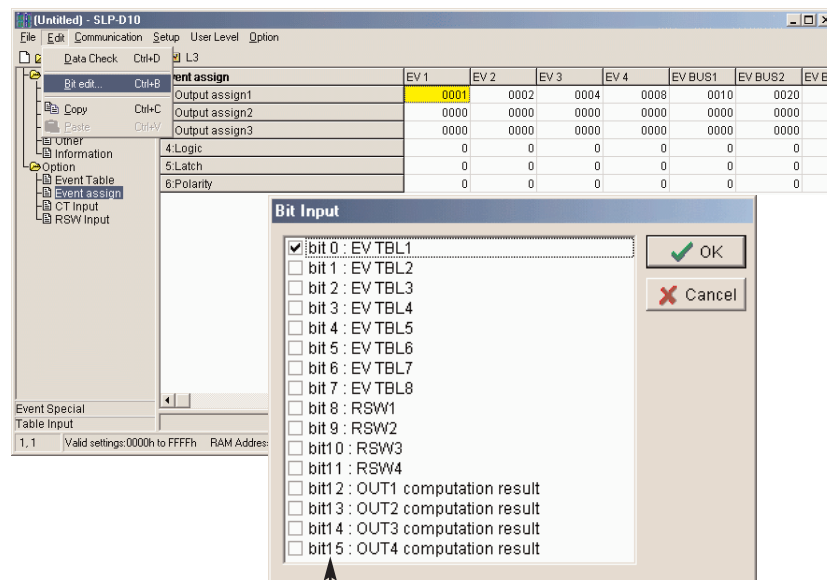

Select the contents to be assigned here.
 (☑: Selected, ☐: Not selected)

- Setup window with the cursor placed in the Output assign2 row

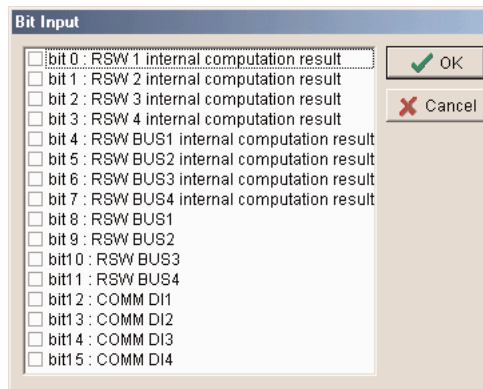

- Setup window with the cursor placed in the Output assign3 row

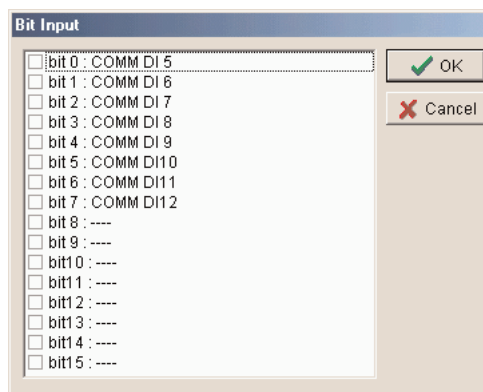

The availability of Output assign1, Output assign2 and Output assign3 depends upon the type of setup contents.

3) Logical action setup

When two or more setup items have been selected, specify AND or OR in the Logic setup menu. If not specified, OR will be selected.

4) Logical action setup

If it is necessary to change the Latch or Polarity setting, specify your selection.

4. External Switch Input Special Operation

■ Internal Structure of External Switch Input Special Operation

- Normal status

Normally, the factor to switch the function of RSW is fixed as follows:

Input terminal name	Available parameters	Name of the RSW to be activated	Remarks
RSW input 1	<ul style="list-style-type: none"> • RSW type • Logic (0: OR 1: AND) • Polarity (0: Direct 1: Reverse) 	RSW1	Available for models with an external terminal only
RSW input 2		RSW2	
RSW input 3		RSW3	
RSW input 4		RSW4	
RSW bus input 1		RSW5 (RSW BUS1)	Side connector event bus input
RSW bus input 2		RSW6 (RSW BUS2)	
RSW bus input 3		RSW7 (RSW BUS3)	
RSW bus input 4		RSW8 (RSW BUS4)	

- When the RSW input special operation is used

It is possible to freely select the factors to switch the functions set in the RSWs and perform OR/AND operations for them.

Selecting various factors to activate RSW functions	Available parameters	Name of the RSW to be activated
<u>Selecting factors for RSW activation</u> (Multiple items selectable from among the following 40 types) <ul style="list-style-type: none"> • EV TBLs 1 to 8 • Event outputs 1 to 4 • RSW inputs 1 to 4 • OUT 1 to 4 internal computation results • RSW TBL 1 to 8 internal computation results • RSW bus inputs 1 to 4 • Communications DI1 to DI12 	<ul style="list-style-type: none"> • RSW type • Logic (0: OR 1: AND) • Polarity (0: Direct 1: Reverse) 	RSW1
		RSW2
		RSW3
		RSW4
		RSW5
		RSW6
		RSW7
		RSW8

- Every model is standardly equipped with 8 RSW input tables including those without external contact input. Consequently, it is possible to control the state of an instrument for up to 8 items individually.

• Block diagram of input assignment

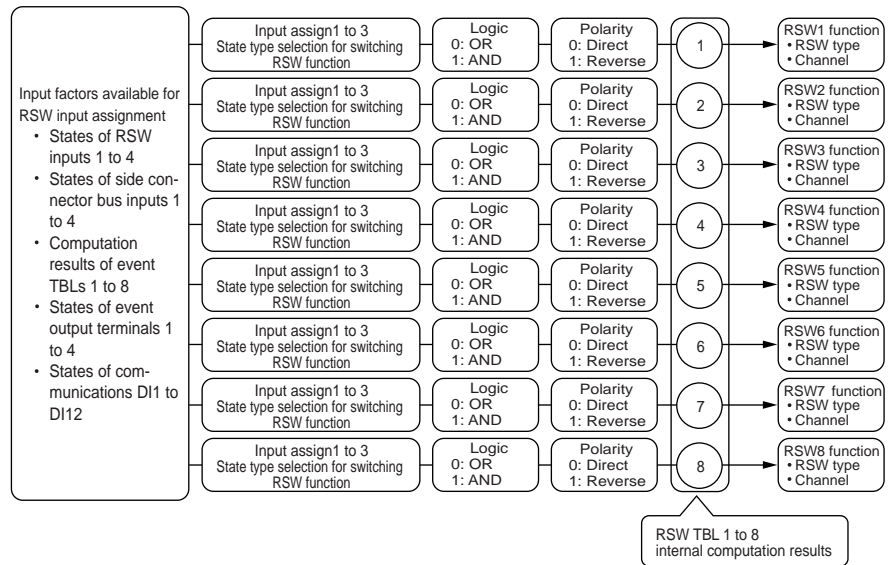

■ Operating Procedures for RSW Input Special Operation

If you want to use the special operation of RSW input, set following the procedures shown below. The RSW input special operation does not operate without these settings.

Make settings following the steps below:

- (1) Specifying the use of RSW input special operation
- (2) Setting up the contents of RSW input action (RSW input table)
- (3) Setting up the RSW input source and logical action

Detailed procedures are as follows.

● Setting procedures

- (1) Specifying the use of RSW input special operation

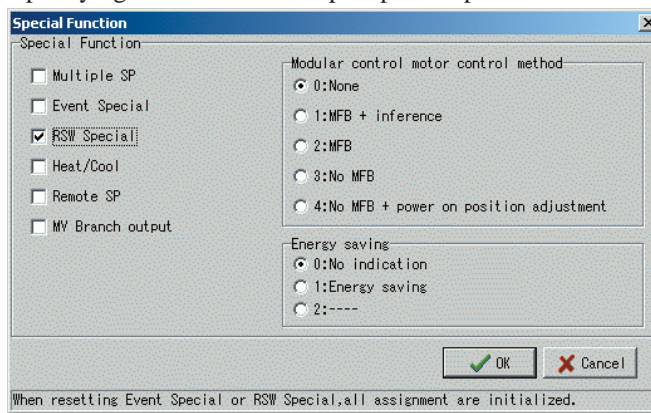

On the PC loader, select [Setup] → [Special Function], then check [RSW Special] on the Special Function window.

>> The contents of RSW input settings and the actual input are separated.

Moreover, the [Input assign1], [Input assign2], [Input assign3] and [Logic] items are newly added to [RSW Input].

The separated RSW setting unit is called an [RSW Input Table].

The assignment of the RSW input table to the desired input source is performed with [Input assign1], [Input assign2] or [Input assign3].

- (2) Setting up the contents of RSW input action (RSW input table)

Select [Option] → [RSW Input] (shown below) to set up the contents of RSW input action.

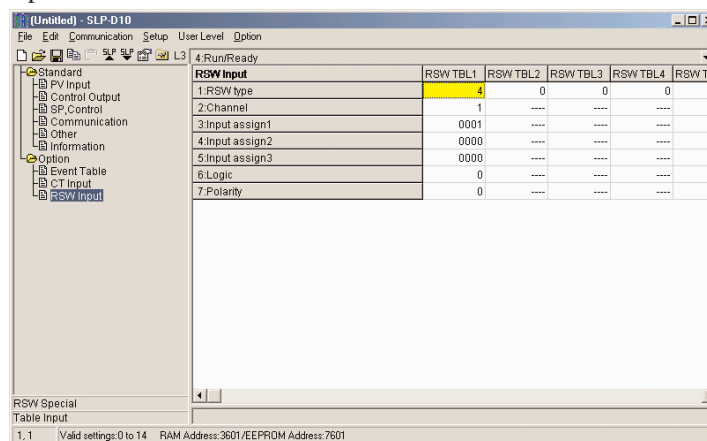

The setup contents of the RSW input tables (RSW_TBL1 to RSW_TBL8) are displayed on the horizontal axis of the screen. Specify the desired "RSW type" and "Channel".

(3) Setting up the RSW input source logical action

Specify the RSW input type to operate the setup contents of the RSW input tables (RSW_TBL1 to RSW_TBL8) displayed on the horizontal axis using [Input assign1], [Input assign2] or [Input assign3].

With the cursor placed at the column of Input assign1 or Input assign2, select [Edit] → [Bit Input] and the below window will appear. Set up the desired input type here.

1) Setting up the input type

Setup window with the cursor placed at the column of Input assign1

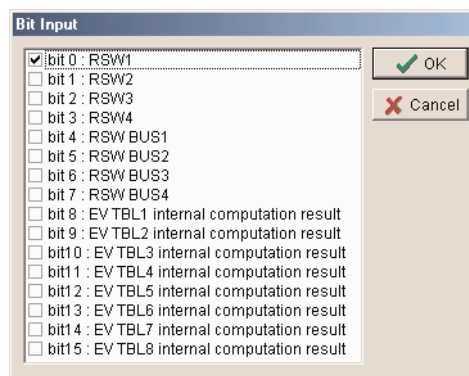

Select the contents to be assigned here.

(: Selected, : Not selected)

- Setup window with the cursor placed at the column of Input assign2

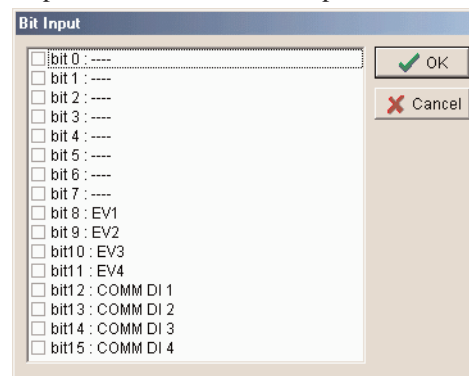

- Setup window with the cursor placed at the column of Input assign3

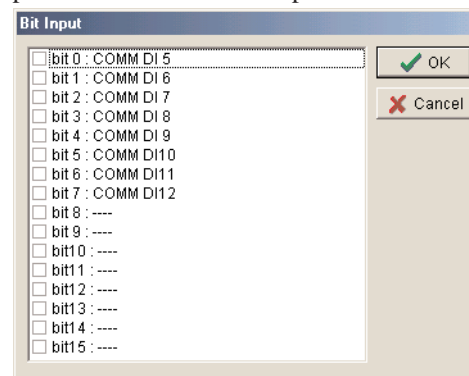

2) Logical action setup

When two or more number of setup items have been selected, specify AND or OR in Logic setting. If not specified, OR will be selected.

■ Sample Applications Combining the Event Output Special Operation and the RSW Special Operation

The sample applications are shown below. They are only a few cases among those to be realized by combined settings of new functions. The widest range of functions can be realized by setting event types, RSW functions and I/O conditions (types, logical operations, polarity and latch) of buses, etc., freely as required.

● ORing the event (alarm) results of multiple DMC10s and issuing an alarm

- In a system composed of 15 DMC10 units with four channels each (total of up to 60 PV channels) linked via side connectors, if either of deviation event state (reverse action) and alarm event state (reverse action) has satisfied the event generation condition in any one of the units, the event module will issue an alarm.

● ANDing multiple event (alarm) results (up to 8 points) in a DMC10 and issuing an alarm

- Example: If the deviation of any channel is out of the range (this is determined by the deviation event) and the PV has surpassed the preset value (this is determined by the PV upper limit event), an On signal is issued to the bus. This signal places all the other DMC10s linked to this unit in the Ready state (using the external switch table).

● ANDing the event results of multiple PV channels (up to 4 channels) in a DMC10 and issuing an alarm

- Example: An alarm is issued when the deviations of all the PV 1 to 4 channels have reached the preset value (this is determined by the deviation event).

● Programming with a simple time control

- Example: If the deviations of all the PV 1 to 4 channels have reached the preset value (this is determined by the deviation event), the SP set is automatically changed (using the external switch input) after 120 seconds (using the event ON/OFF delay) and the temperature rises to the next setting value.

● With communications DIs, switching the states of up to 15 units X 4 channels DMC10s (Run/Ready state, for example) by sending the command only once

- Example: The On/Off state is transmitted to the communications DI1 of one single DMC10 from the host computer over a communications line. This state is output to the external bus and, responding to the state of this bus, the Run/Ready states of all the linked PV channels change at the same time. (Conventionally, it was needed to write the new setting to all the channels individually by 60 times of transmission. Moreover, at least a delay of several seconds was observed.)

5. Setting When Heat/Cool Control Is Used (available for 2-channel model DMC10D only)

To use the heat/cool control function, it is necessary to select the advanced function 2-channel model DMC10D, then set up the heat/cool control and output setting assignment.

For the applicable models, see "[Configuration of DMC10S, DMC10D model numbers](#)" on page 1-2.

■ Setting Procedures

(1) Specifying the heat/cool control

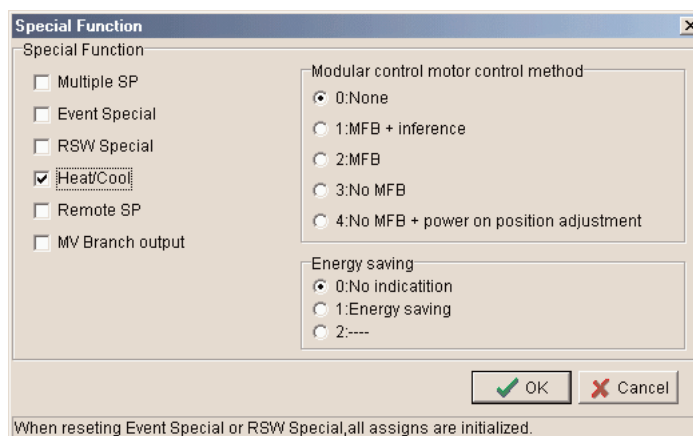

On the PC loader, select [Option] → [Special Function], then check [Heat/Cool] on the Special Function window.

! Handling Precautions

It is not allowed to use the heat/cool control together with the remote SP control.

(2) Setting up the output assignment of heat/cool control

Select the types of heat/cool control output and cool control output.

Assignment is forcibly performed according to the setting contents.

As the output terminals, OUT1/OUT2 (control output terminals), EV3/EV4

(event output terminals) or AUX1/AUX2 (auxiliary output terminals) are used.

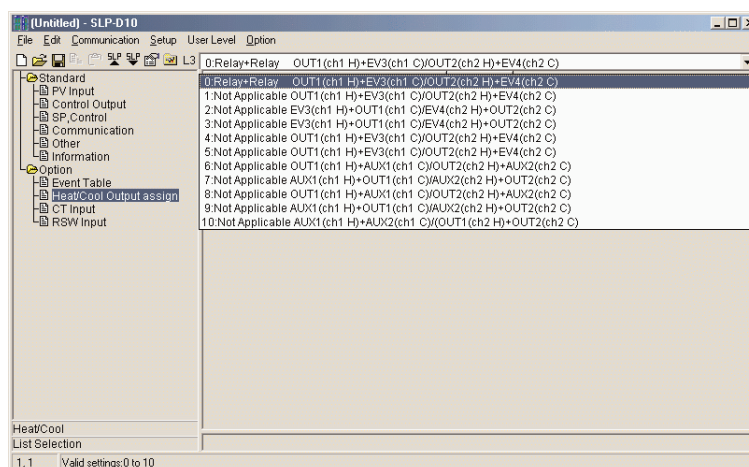

6. Settings When Remote SP Is Used (available for DMC10D only)

■ Setting Procedures

(1) Specifying the remote SP control

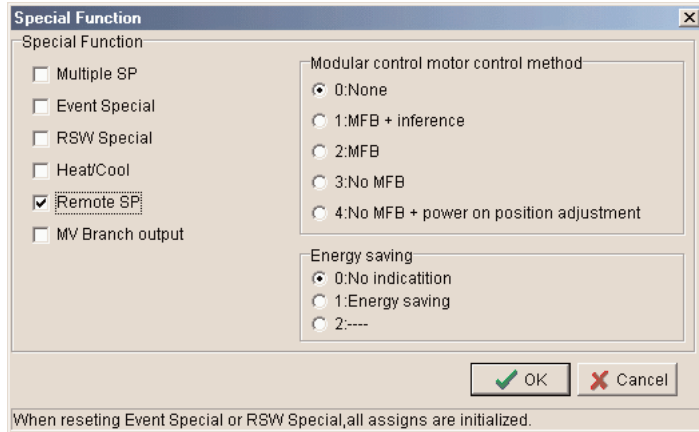

On the PC loader, select [Option] → [Special Function], then check [Remote SP] on the Special Function window.

In [PV Input] in the [Standard] menu, the input channel indication for remote SP changes to RSP.

! Handling Precautions

It is not allowed to use the remote SP control together with the heat/cool control.

7. Settings When Inter-Channel Deviation Control Is Used (available for DMC10D only)

In the advanced function models, it is possible to use the control method where the inter-channel PV deviation is used as an SP. This method is used by setting up so that the channels other than the master one perform the inter-channel deviation control while the master channel performs the normal control.

■ Setting Procedures

(1) Set up the items from 14 to 17 in [Control Output] in the [Standard] menu.

The following is a sample setting with the channel 1 as the master channel.

Control Output		ch 1	ch 2
1:Control output		1	1
2:Control action		0	0
3:Time proportional cycle		10	10
4:Time proportional cycle mode		0	0
5:Initial output of PID control		0.0	0.0
6:Output operation at changing Auto/Manual		0	0
7:Preset manual value		0.0	0.0
8:Output at READY		0.0	0.0
9:Output at PV alarm		0.0	0.0
10:Output variation limit		100.0	100.0
11:Self-tuning startup condition		0	0
12:Self-tuning start-up band		0.5	0.5
14:Differential control between channel		0	1
15:Base channel for differential control		----	1
16:Type of channel differential control		----	0
17:Value of channel differential control		----	0

- **14: Differential control between channel**
Specifying the differential control between channels is used or not.
(0: Used, 1: Not used)
- **15: Base channel for differential control**
Specifying the channel on the other end of the deviation to be set from among the channels 1 to 4
- **16: Type of channel differential control**
Specifying either deviation from the following:
 - Deviation from the PV of the channel on the other end: Normal selection (when the PV value of the master channel is stable)
 - Deviation from the SP of the channel on the other end: Select this when the PV value of the master channel is unstable
(0: SP = PV of the specified channel + value of channel differential control,
1: SP = SP of the specified channel + value of channel differential control)
- **17: Value of channel differential control**
Setting up the value of differential control

Revision History

Printed Date	Manual Number	Edition	Revised pages	Description
Sep. 2000	CP-UM-5143E	1st Edition		
July 2001		2nd Edition		Overall revision
Sep. 2001		3rd Edition	10-18 10-29, 10-30	Communications DI input (??) to Communications DI input (1 to 12) changed. Input assignment1 to Input assignment2 changed, Input assignment2 to Input assignment1 changed.
Nov. 2001		4th Edition	1-2 10-18	Additional Processing of model numbers, D0:Provision of Inspection Sheet to Inspection Certificate provided changed, Y0:Traceability supported to Complying with the traceability certification changed. COMM1 to COMM12 added.
Feb. 2002		5th Edition	5-1 7-2 10-42 to 10-44 10-45 to 10-46	Note changed. Handling Precautions Item added. 10-9 Detail Explanation on Communication Conditions added. Section 10-9 to 10-10 changed, Old 10-42 to 10-43 page.
Apr. 2002		6th Edition	8-17 8-21	30:Loop diagnosis 2 ON and OFF Delay added "00:00:00 to 99:59:59" 26:Deviatiob lower limit Illustrations changed
May 2002		7th Edition	11-2 14-3	(1) of •Checksum(LRC), It is (1) to (3) ••••• → It is (2) to (3) ••••• changed. Range No. 31 to 34 of ● RTD PV input type/range table added.
Apr. 2003		8th Edition	1-2 4-1 5-2 8-1 8-15 8-30, 10-26 10-17, 10-25 to 10-27, 10-30 to 10-32 11-1 14-1 14-6 App.-5	RESTRICTIONS ON USE changed. Note of 1 List of CMC10 related products added Description replaced between Event relay output (CH1/2) and External switch input (CH1/2) of 2-channel model. Handling Precautions Item added. Setting range of input type changed. Factory setting of channel targeted for LED operation, 0:OR operation on all channels → 1:channel1 changed. External bus definition added "H"added of Hex Item Features Item 2 changed. Rated power voltage in Reference conditions → Power voltage changed. Dotted line between AUX CH1 and AUX CH2 changed to solid line in the figure of "Isolation between inputs and outputs". Description added of ●When the event output special operationused table
Aug. 2004		9th Edition	4-5 4-6	Manual name changed. RESTRICTIONS ON USE changed. Screw tightening torque changed. ■Connecting the Power Supply: Explanation added to apply UL. ■Connecting for CPL Communications: Item added to Handling Precautions.

Printed Date	Manual Number	Edition	Revised pages	Description
Aug. 2004	CP-UM-5143E	9th Edition	4-8	<ul style="list-style-type: none"> ●When connecting to a PGM10N/F (made by Yamatake Corporation): Added. ●When connecting to a G3PA (made by Omron Corporation): G3NA deleted.
			7-2	Operating system OS added.
			7-7	Menu screen changed.
			8-20	Item No.19: Explanation in the “direct action” column changed.
			8-22	●Alarm OR action: Explanation added.
			8-30	Latch: Description in the Setting Range” column changed to “1: ON (latch in ON), 2: ON (latch in OFF)”.
			8-32	Latch: Description in the “Description” column changed to “1: ON (latch in ON),2: ON (latch in OFF)”.
			9-1	●Position proportional control: “international branch control” deleted.
			10-7	<ul style="list-style-type: none"> ●“Maximum number of read” changed to “Maximum number of write” “End code” changed to “Status code”.
			10-8 to 10-11	<ul style="list-style-type: none"> ●Send message: “four or eight hexadecimal digits” changed to “four hexadecimal digits”. “End code” changed to “Status code”.
			10-9	●RAM area: “Up to 28 words” changed to “Up to 27 words”.
			10-15	“RS-232C” changed to “RS-485”.
			10-16 to 10-29	Table revised. Old pages 10-16 to 10-32.
			10-27	Latch: Description in the “Data information” column changed to “1:ON (latch in ON),2:ON (latch in OFF)”.
			10-30	Items 6 and 7 for CH1 or CH2 motor adjustment error: Description changed. Old page 10-33.
			10-31 to 10-42	Old pages 10-34 to 10-46.
			11-2	●MODBUS ASCII: “The application layer” in the description changed to “(3)”.
11-3	●MODBUS RTU: “The application layer” in the description changed to “(2)”.			
11-4	■Other Specifications: Data count “16(WRITE)” in the table changed to “10(WRITE)”.			
12-5	Wiring diagram: “A” and “C” changed.			
14-1	Screw tightening torque: Description in the “Specifications” column changed.			
14-4	“Load current” added. “Current output” deleted.			
App.-6, App.-7	Latch: Changed to “1:ON (latch in ON), 2:ON (latch in OFF)”.			
Mar. 2005		10th Edition	10-23	“Use of output branch control”: RAM address Hex “7903H” changed to “0F3F”, ROM address Decimal “0F3F” changed to “7903H”, ROM address Hex “1DEFH” changed to “1EDFH”.
			10-29	“Data format”: ROM address Decimal “-” changed to “7802H”, ROM address Hex “-” changed to “1E7AH”. “Transmission speed”: ROM address Decimal “-” changed to “7803H”, ROM address Hex “-” changed to “1E7BH”.
			14-2	■PV Input: “Input type” added. “Reception resistance”: Max. 50Ω changed to Max. 120Ω.

Printed Date	Manual Number	Edition	Revised pages	Description
Nov. 2005	CP-UM-5143E	11th Edition	8-4 10-33 10-34 10-35 to 10-37 10-36, 10-37 10-38 13-3 App.-8	External switch input Type of action Setting Range No.13 and 14 changed. Table 10-4 No.1 to 8 and No.9 to 16 Remarks added. Table 10-5 No.1 to 4 and No.5 to 8 Remarks added. Table 10-6 No.1 to 4 Remarks changed. No.5 to 8 and No.9 to 12 Remarks added. Table 10-8 to 10-13 title and remarks added. Table 10-10, 10-12, 10-13 Value and Note changed. Table 10-14 Item Communication DI5 to DI12→ DI1 to DI8 changed. No.9 to 12 Item changed. No.13 to 16 Value changed. Note changed. ■ Host Communications Related Trouble • No response in communications Cause and Remedy 1 tem added. 1) Output destination picture changed.
Mar. 2006		12th Edition	10-26, 10-27	Type of action of RSW1 to RSW4 and RSW bus1 to RSW bus4: Item Data Information 0 to 12 → 1 to 14 changed.
Jan. 2007		13th Edition	iii, iv iii, 1-2 2-2, 3-2 3-1 3-1, 3-2 7-2 7-3 7-6 to 7-9 7-10 to 7-22 9-2 10-24 10-25 10-26 to 10-27 14-2	System disk: Floppy disk changed to CD-ROM. Model No: SLP-D10J20 changed to SLP-D10J60 DIN rail stopper changed to DIN rail locking tab Mounting Locations: description of the 1st and 5th item added. ● Mount each DMC10 module vertically as in the figure below added. Operating system: Windows95 deleted, Serial port deleted, USB port added, ● Hardware configuration changed. ● Installing SLP-D10: (1) to (3) changed. ■ Device Driver Installation for USB Loader Cable added. Old pages 7-7 to 7-18 ● Time proportional power saving mode: branch control changed to deviation control 3293 Data Inf.: 1:ON changed to 1:1/2 Energy saving, 2: 1/4 Energy saving 3349: 0D15H: 7349: 1CB5H changed to 3348: 0D14H: 7348: 1CB4H RSW1 to RSW4, RSWbus1 to RSWbus4: Data Inf. 1 to 14 changed to 0 to 14 ■ PV Input: Reception resistance changed to Input Impedance, ● Operation at a thermocouple input line break added to Can be changed by setting.
May 2007		14th Edition	i iii, 1-2 10-4 10-16	SAFETY PRECAUTIONS ■ Examples changed. SLP-D10J60 changed to SLP-D10J50. List of data link layer data definitions Character code 0 to 07H changed to 0 to 0FH. ■ Word Address Data Decimal point information Δ1 Added. Data information for RAM address 1028-1029 changed 1:AUTO to 0:AUTO, and changed 2:MANUAL to 1:MANUAL.

Printed Date	Manual Number	Edition	Revised pages	Description
May 2007	CP-UM-5143E	14th Edition	10-16	Data Information for RAM addresses 1032–1033 changed 1:RUN to 0:RUN, and changed 2:READY.
			10-17	Data Information for RAM addresses 1036–1037 changed 1:LOCAL to 0:LOCAL, and changed 2:REMOTE to 1:REMOTE.
			10-23	Item for RAM addresses 1052, 1055, 1058, 1061, 1064, 1067, 1070, 1073 changed (hours) to (minutes). Item for 3231, 3232 added.
			10-24	Data information for RAM address 3235–3236 changed 1 to 6 to 3 to 30. Data information for RAM address 3275, changed page 9-7 to page 9-6.
			14-2	Data Information for RAM addresses 3286–3289 changed page 9-10 to page 9-6. ■About Zener Barrier Adjustment range 27, 28 added. ■PV Input Allowable wiring resistance range 31, 32, 33, 34 added.
Jan. 2008		15th Edition	10-18	Data information for RAM address 1111-1114 added.
			14-2	Allowable input voltage added.

azbil

Yamatake Corporation
Advanced Automation Company

1-12-2 Kawana, Fujisawa
Kanagawa 251-8522 Japan

URL: <http://www.azbil.com>

Printed on recycled paper. (07)

Specifications are subject to change without notice.

Printed in Japan.
1st Edition: Issued in July 2000 (R)
15th Edition: Issued in Jan. 2008 (A)