

CMC15G

Multifunction Gateway Communication Controller

"Installation & Configuration"

User's Manual



Thank you for purchasing the CMC15G Multifunction Gateway Communication Controller.

This manual contains information for ensuring the correct use of the CMC15G. It also provides necessary information for installation, maintenance, and troubleshooting.

This manual should be read by those who design and maintain equipment that uses the CMC15G. Be sure to keep this manual nearby for handy reference.

Yamatake Corporation

RESTRICTIONS ON USE

This product has been designed, developed and manufactured for general-purpose application in machinery and equipment.

Accordingly, when used in applications outlined below, special care should be taken to implement a fail-safe and/or redundant design concept as well as a periodic maintenance program.

- Safety devices for plant worker protection
- Start/stop control devices for transportation and material handling machines
- Aeronautical/aerospace machines
- Control devices for nuclear reactors

Never use this product in applications where human safety may be put at risk.

NOTICE

Be sure that the user receives this manual before the product is used.

Copying or duplicating this user's manual in part or in whole is forbidden. The information and specifications in this manual are subject to change without notice.

Considerable effort has been made to ensure that this manual is free from inaccuracies and omissions. If you should find an error or omission, please contact Yamatake Corporation.

In no event is Yamatake Corporation liable to anyone for any indirect, special or consequential damages as a result of using this product.

©2008 Yamatake Corporation ALL RIGHTS RESERVED

Conventions Used in This Manual

- To prevent injury to the operator and others, and to prevent property damage, the following types of safety precautions are indicated:



CAUTION

Cautions are indicated when mishandling this product might result in minor injury to the user, or only physical damage to the product.

- In describing the product, this manual uses the icons and conventions listed below.



Use caution when handling the product.



The indicated action is prohibited.



Be sure to follow the indicated instructions.



Handling Precautions:

Handling Precautions indicate items that the user should pay attention to when handling the CMC15G.



Note:

Notes indicate information that might benefit the user.



:

This indicates the item or page that the user is requested to refer to.

(1), (2), (3):

Numbers within parentheses indicate steps in a sequence or parts of an explanation.

[ABC] button:

Indicates a selectable button on a personal computer screen.

[File], [Edit]:

Indicates messages and menus displayed on the personal computer.

[AB] → [XYZ]:

Indicates menu selection on a personal computer.

[Enter] key:

Indicates keys on the keyboard.

[Shift]+[f.5] key:













Indicates the operation of pressing the [f.5] key on the keyboard while the [Shift] key is pressed.

>>:

Indicates the result of an operation, details displayed on the personal computer or other devices, or the state of the device after operation.

Safety Precautions

CAUTION

	Use Yamatake Corporation's SurgeNon if there is the risk of power surges caused by lightning. Failure to do might cause fire or faulty operation.
	Prevent the total power consumption of all linked modules from exceeding 100W.
	Before wiring, removing or installing the CMC15G, be sure to turn the power OFF. Failure to do so might cause faulty operation.
	Do not disassemble the CMC15G. Doing so might cause faulty operation.
	Use the CMC15G within the operating ranges (temperature, humidity, voltage, vibration, shock, mounting direction, atmosphere, etc.) recommended in the specifications. Failure to do so might cause fire or faulty operation.
	Do not block ventilation holes. Doing so might cause fire or faulty operation.
	Wire the CMC15G in compliance with established standards, using the specified power source and recognized installation methods. Failure to do so might cause electric shock, fire or device failure.
	Firmly tighten the terminal screws at the torque listed in the specifications. Insufficient tightening of terminal screws might cause fire.
	Do not use unused terminals on the CMC15G as relay terminals. Doing so might cause electric shock, fire or faulty operation.
	Do not allow lead clippings, chips or water to enter the CMC15G case. Doing so might cause fire or faulty operation.
	Do not short-circuit the batteries, and do not get them wet. If short-circuited, they may over-heat or catch fire.
	Do not throw used batteries into fire or discard them as general garbage. When discarding them, follow local rules and regulations.
	When disposing of the CMC15G, dispose of it appropriately as industrial waste in accordance with local bylaws and regulations.

The Role of This Manual

A total of four different manuals are available for the CMC15G. Read them as necessary for your specific requirements. If a manual you require is not available, contact Yamatake Corporation or its dealer.

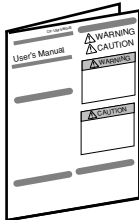

CMC15G Multifunction Gateway Communication Controller Manual No. CP-UM-5463JE

This manual is supplied with the product. This manual describes the safety precautions, installation and wiring.

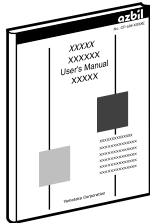

CMC15G Multifunction Gateway Communication Controller User's Manual: "Insatallation & Configuration" Manual No. CP-SP-1277E

This Manual.

Personnel in charge of design, manufacture, operation, and/or maintenance of a system using this unit must thoroughly read this manual.

This manual also describes the installation, wiring, connections for communication, all functions and settings of this unit with the GatewayEditor, operating procedures, troubleshooting, and specifications.

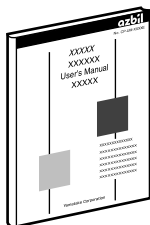

CMC15G Multifunction Gateway Communication Controller User's Manual: "Communications Connection" Manual No. CP-SP-1278E

Personnel in charge of combine the CMC15G with PLCs made by other manufacturers and dedicated board computers to build systems must thoroughly read this manual.

This manual describes how to connect to PLCs, address maps that correspond to PLCs, and other operations and settings required for making applications using PLCs.

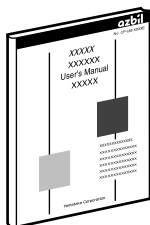

CMC15G Multifunction Gateway Communication Controller User's Manual: "Logging Function" Manual No. CP-SP-1279E

Personnel in charge of design, manufacture, operation, and/or maintenance of a system using logging function by CMC15GD001 advanced model must thoroughly read this manual.

This manual describes detailed instructions on logging functions, details about LogViewer.

Organization of This User's Manual

This manual is organized as follows:

Chapter 1. OVERVIEW

This chapter describes the applications, features, model selection guide, and part names and operation flow of the functions of the CMC15G.

Chapter 2. PART NAMES AND FUNCTIONS

This chapter describes the names and functions of parts on the CMC15G.

Chapter 3. MOUNTING

This chapter describes the environmental conditions and installation procedures when installing the CMC15G.

Chapter 4. WIRING

This chapter describes the wiring procedures, wiring precautions, and connection examples.

Chapter 5. BASIC FUNCTIONS

This chapter describes data transmission, module setup and internal event.

Chapter 6. LOGGING FUNCTION

This chapter describes logging function.

Chapter 7. EXTENDED FUNCTIONS AND OTHER FUNCTIONS

This chapter describes the extended function and the option configuration that is functions other than the basic functions.

Chapter 8. GATEWAYEDITOR

This chapter describes the overview, the installation, the start, the end, and the operation method of the GatewayEditor that is a set tool of the CMC15G.

Chapter 9. WORKING WITH GATEWAYEDITOR

This chapter describes a setting method and a set item to operate the CMC15G in the GatewayEditor.

Chapter 10. CONNECTING TO THE CMC15G WITH GATEWAYEDITOR

When the GatewayEditor is connected with the CMC15G with USB, this chapter describes the method of installing a necessary device driver. Moreover, it describes the online manipulation done from the GatewayEditor.

Chapter 11. TOOLS

This chapter describes the tool of an environmental configuration etc.

Chapter 12. CONTACTS AND REGISTERS INSIDE THE CMC15G

This chapter shows special contacts and special registers list of the CMC15G.

Chapter 13. MAINTENANCE

This chapter describes the method of exchanging the backup batteries.

Chapter 14. SPECIFICATIONS

This chapter describes the general specifications and external dimensions of the CMC15G.

Chapter 15. TROUBLESHOOTING

This chapter describes the cause investigation of the trouble and the treatment method generated in using the CMC15G.

Contents

Conventions Used in This Manual	
Safety Precautions	
The Role of This Manual	
Organization of This User's Manual	

Chapter 1. OVERVIEW

1-1 Overview and Features	1-1
■ Overview	1-1
■ Features	1-2
1-2 Model Number Guide	1-3
■ CMC15G	1-3
■ Smart loader package	1-3
■ Maintenance parts (option)	1-3
1-3 Function Overview	1-4
■ Kinds of mode	1-4
■ Basic functions	1-4
■ Logging function	1-6
■ Extend functional option configuration	1-8
■ Digital signal input/output bus	1-8
■ Loader through-communication	1-9

Chapter 2. PART NAMES AND FUNCTIONS

■ Body	2-1
■ Base	2-1
■ Communication parts for module connection	2-2
■ Display unit	2-4
■ Backup battery	2-6

Chapter 3. MOUNTING

■ Mounting locations	3-1
■ Linking modules	3-1
■ Mounting method	3-1
■ Mounting the body on the base	3-2

Chapter 4. WIRING

■ Recommended cable	4-1
■ Wiring precautions	4-1
■ Connecting the power supply	4-1
■ Connecting for CH1 communications (RS-232C)	4-2

■ Connecting for CH2 communications (RS-485)	4-2
■ Connecting for CH3 communications (RS-485)	4-2
■ Connecting for CH4 communications (RS-485)	4-3
■ Device connections and configuration	4-3
■ Setting the device address	4-4

Chapter 5. BASIC FUNCTIONS

5-1 Data Transmission	5-1
■ Cyclic execution	5-1
■ Triggers	5-3
5-2 Module Setup	5-5
■ Triggers	5-6
5-3 Internal Event	5-7
■ Cyclic execution	5-7
5-4 Group	5-8
■ Group	5-8
5-5 Execution Conditions and Processing for Each Function	5-9
■ Execution conditions	5-9
■ Enabled-disabled setting	5-10
■ Sequential execution	5-11
■ Notification process	5-13
5-6 Communication Error	5-17
■ Occurrence of communication error	5-17
■ Operation if there is a communication error	5-17

Chapter 6. LOGGING FUNCTION

6-1 Continuous Trend	6-1
■ Description of operation	6-1
■ Operation if an error occurs	6-2
6-2 Captured Trends Function	6-3
■ Description of operation	6-3
6-3 Data Log	6-6
■ Description of operation	6-6
6-4 Event Log	6-8
■ Description of operation	6-8
6-5 Groups and Execution Conditions	6-10
■ Groups	6-10
■ Execution conditions	6-10

Chapter 7. EXTENDED FUNCTIONS AND OTHER FUNCTIONS

7-1 Status Notification	7-1
■ Running notification	7-1

■ Battery alarm notification	7-2
■ Capture notification/Capture limit notification	7-3
7-2 Communication Error Notification	7-4
7-3 Date and Time Adjustment	7-5
7-4 Option Configuration	7-6
■ Node address	7-6
■ Startup delay	7-6
■ Trigger device initialization	7-6
■ Initialization of completion notification device and error notification device	7-8
7-5 Digital Signal Input/Output Bus	7-9
7-6 Loader Through-Communication	7-10
■ Setup of loader through-communication	7-10
■ Quitting loader through-communication	7-13

Chapter 8. GATEWAYEDITOR

8-1 Overview of GatewayEditor	8-1
■ Functions	8-1
■ System requirements	8-1
8-2 Installing GatewayEditor	8-2
■ Installing the SLP-G15	8-2
■ Uninstalling the SLP-G15	8-5
■ Upgrade-installing and maintenance-installing the SLP-G15	8-5
8-3 Starting up and Exiting GatewayEditor	8-8
■ Starting up GatewayEditor	8-8
■ Exiting GatewayEditor	8-8
8-4 Operation Flow	8-9
8-5 Configuration Functions	8-10
8-5-1 Main window	8-10
■ Screen structure	8-10
■ Menu descriptions	8-12
8-5-2 Project view	8-16
■ Screen structure	8-16
■ Structure list	8-16
■ Creating a configuration sheet	8-18
■ Opening a configuration sheet	8-19
■ Editing a sheet	8-19
8-5-3 Function configuration tab sheet	8-21
■ Screen structure	8-21
■ Operating procedures	8-22
8-5-4 Module selection palette and address selection palette	8-25
■ Screen structure	8-25
■ Operating procedures	8-29
8-5-5 List of configuration errors	8-36

Chapter 9. WORKING WITH GATEWAYEDITOR

9-1	Creating a Project.....	9-1
9-1-1	Creating a new project.....	9-1
9-1-2	Opening a project.....	9-2
9-1-3	Re-opening a project.....	9-3
9-1-4	Saving a project.....	9-4
9-1-5	Closing a project.....	9-5
9-1-6	Checking the project information.....	9-6
	■ General.....	9-6
	■ Comment.....	9-6
9-1-7	Outputting a CSV file.....	9-7
	■ Output contents.....	9-7
	■ Outputting to a CSV file.....	9-8
9-2	System Configuration.....	9-9
9-2-1	Module constitution.....	9-9
	■ Screen layout.....	9-9
	■ Operating procedures.....	9-10
9-2-2	Option configuration.....	9-13
	■ General.....	9-13
	■ Initialization.....	9-14
9-3	Basic Function Configuration.....	9-15
9-3-1	Data transmit.....	9-15
	■ Screen layout.....	9-15
9-3-2	Module setup.....	9-19
	■ Screen layout.....	9-19
9-3-3	Internal event function.....	9-22
	■ Screen layout.....	9-22
9-4	Logging Function Configuration.....	9-27
9-4-1	Trend.....	9-27
	■ Screen layout.....	9-27
9-4-2	Data log.....	9-31
	■ Screen layout.....	9-31
9-4-3	Event log.....	9-34
	■ Screen layout.....	9-34
9-5	Extended Function Configuration.....	9-37
9-5-1	Status notification.....	9-37
	■ Screen layout.....	9-37
9-5-2	Communication error notification.....	9-38
	■ Screen layout.....	9-38
9-5-3	Date and time adjustment.....	9-39
	■ Screen layout.....	9-39

Chapter 10. CONNECTING TO THE CMC15G WITH GATEWAYEDITOR

10-1	Connections.....	10-1
------	------------------	------

■ USB connection	10-1
■ Loader jack connection	10-1
10-2 Communication	10-7
10-2-1 Communication status	10-7
■ Screen layout	10-7
10-2-2 Download (PC → CMC15G)	10-8
10-2-3 Upload (CMC15G → PC)	10-9
10-2-4 Online monitor	10-10
■ Screen layout	10-10
■ Operating procedures	10-11
10-2-5 Operation mode change	10-12
■ Screen layout	10-12
■ Operating procedures	10-12
10-2-6 Online module setup	10-13
■ Screen layout	10-13
■ Operating procedures	10-13
10-2-7 Online date and time setting	10-15
■ Screen layout	10-15
■ Operating procedures	10-15
10-2-8 CMC15G information display	10-16
■ Screen layout	10-16
■ Operating procedures	10-16
■ Basic information	10-18
■ Operation history	10-19
■ Communication error history	10-20
10-2-9 Upgrading the system	10-23
■ Automatic update	10-23
■ Manual update	10-23

Chapter 11. TOOLS

11-1 Environment Configuration	11-1
■ Communication configuration	11-1
11-2 Changing the Target Model	11-2
11-3 Updating the CMC15G System	11-3

Chapter 12. CONTACTS AND REGISTERS INSIDE THE CMC15G

■ List of devices	12-1
■ Special contacts	12-2
■ Special resisters	12-3

Chapter 13. MAINTENANCE

- Replacing the battery 13-1

Chapter 14. SPECIFICATIONS

- Specifications 14-1
- External dimensions 14-2

Chapter 15. TROUBLESHOOTING

- Diagnosis using the indicator lights 15-1
- Error diagnosis using the CH1 to CH4 indicators 15-2
- Corrective actions in case of an error occurs 15-3

Chapter 1 OVERVIEW

1 - 1 Overview and Features

■ Overview

The CMC15G is a communication controller designed to exchange data between another manufacturer's PLC, a host station, and a Yamatake controller or flowmeter connected as a slave station. By setting simple communication parameters, data can be shared between modules, indicator values can be recorded, etc.

A specially designed PC loader tool, GatewayEditor (model No.: SLP-G15J50), is used to set up the communication parameters and to transmit the data to the CMC15G.

If the advanced CMC15G model is used, data can be saved from connected modules (trend, data log, and event log) to the internal memory. To transmit saved data from the CMC15G's internal memory, a special PC loader tool, the LogViewer (model No. SLP-G15LGV), is used.

👉 Communication Controller CMC15G Multifunction Gateway User's Manual "Logging Function", CP-SP-1279E (for details about LogViewer)

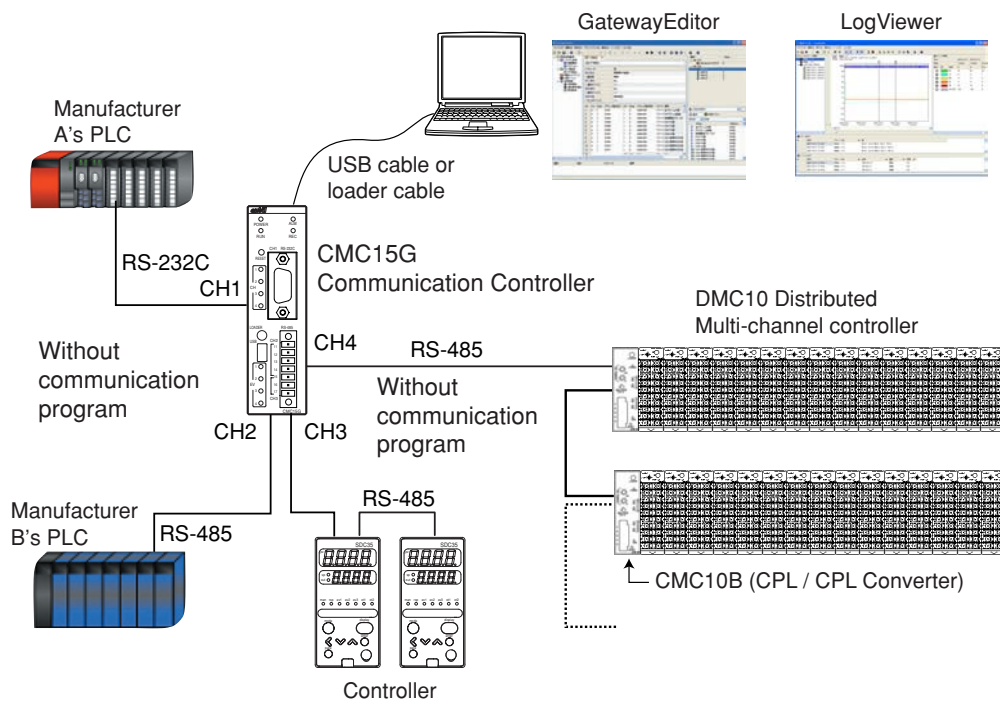

Modules are connected using four serial communication channels and USB ports (or jacks specially designed for loader use), and data can be freely exchanged between modules without the need to write programs.

■ Features

- **Easy installation and management**
The CMC15G is ready for operation, after simple setting of parameters using GatewayEditor. It is not necessary to create a communication program. Additionally, this multifunction gateway can flexibly accommodate design changes, and can be used to easily manage or reuse applications.
- **Excellent expandability**
Since the data area can be allocated freely, the registers of the PLC can be used effectively. Additionally, since the execution timing or type of communications can be set freely, advanced operations are possible, such as changing cycle timing according to the importance of the data or rearranging the communication sequence.
- **Wide variety of functions**
Parameters and/or product type data necessary for operation are distributed to each module in batch mode. This reduces the workload required for initial setup and/or development of an operating program.
- **Powerful design support and debug functions during operation startup**
GatewayEditor supports various debug functions to solve problems caused by incorrect wiring or improper parameter setting at the work site. GatewayEditor can monitor the communication status of each module and the actual execution cycle of each communication in real time.
- **Powerful design support and debug functions during operation startup (CMC15GD01 advanced model)**
The logging function of the CMC15GD01 advanced model provides a wide variety of triggers useful for analyzing and solving problems that occur at the work site.
- **Optimum for complex debugging (CMC15GD01 advanced model)**
The CMC15GD01 advanced model can read out the log data from multiple modules. The status of the slave station and the status of the host station can be saved at the same time.
- **Visual analysis (CMC15GD01 advanced model)**
The LogViewer allows easy determination of the time at which events occurred. It visually presents the state of the trend data at the time recorded in the event log in conjunction with each logging function.
- **Long-term recording (CMC15GD01 advanced model)**
Using the CMC15GD01 advanced model's large-capacity internal memory and real-time monitoring function of the LogViewer makes it possible to record data for an extended period of time.

1 - 2 Model Number Guide

■ CMC15G

Basic Model No.	Function	Module	Option	Specifications
CMC15G	S01			Basic model
	D01			Advanced model
		A		Base module with connectors
			000	None

* To use the logging function, the CMC15GD01 advanced model is required.

■ Smart loader package

Software name	Model No.	Note
Smart loader package (GatewayEditor)	SLP-G15J50	CD for Windows 2000/XP/Vista USB mini-B (5 pins) cable included
Smart loader package (LogViewer)	SLP-G15LGV	CD for Windows 2000/XP/Vista

* To use the logging function, the LogViewer (SLP-G15LGV) is required.

■ Maintenance parts (option)

Part name	Model No.	Note
Replacement battery	81446431-001	

1 - 3 Function Overview

The functions of the CMC15G can be classified into three groups: basic functions, logging functions, and extended functions.

Basic functions include the following:

- Data transmission
- Module setup
- Internal event

These functions are for the exchange of data between the host station and slave station.

Logging functions include the following:

- Continuous trend
- Captured trends
- Data log
- Event log

These functions are for debugging the host station and slave station, and for the saving of log data. The data collected by each function can be checked using the LogViewer.

Extend functions include the following:

- Status notification
- Communication error notification
- Date and time adjustment

These functions are for notification of communication error or for confirming correct communication during data exchange.

In addition to the above functions, optional settings are also available to reduce the load on the host station.

■ Kinds of mode

The CMC15G provides the following modes. Any function can be executed when the CMC15G is in RUN mode.

- RUN mode: Any function operates.
- STOP mode: All functions have stopped.
- THROUGH mode (through-communication):

Through-communication with connected modules is accomplished using the Smart Loader Package for the controller.

■ Basic functions

● Data transmission

This data transmission function shares information between modules connected to the CMC15G. This function reads data from the slave station (such as a controller) periodically and transmits it to the host station (such as a PLC), or it transmits data from the host station to the slave station upon activation of a host station trigger.

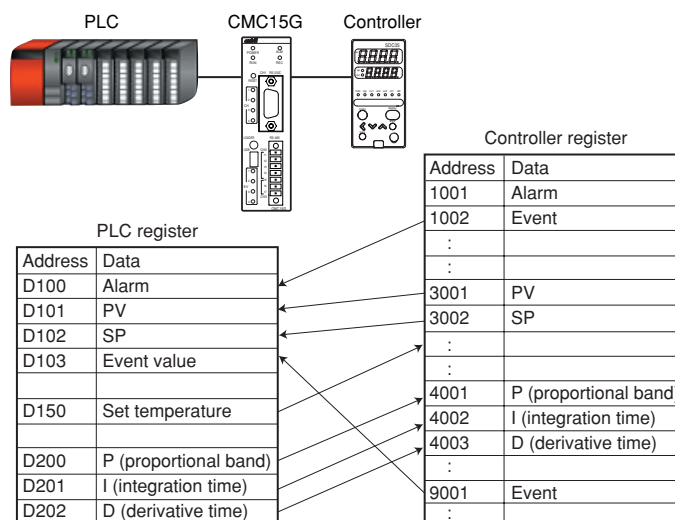

● **Module setup**

This function writes data (values set inside the CMC15G) to connected modules. The initial settings for connected modules and mode change (RUN/READY) for a slave station such as a controller can be written simultaneously upon instruction from the host station. With GatewayEditor, it is also possible to write data in the units used by the modules.

For each module, the setup data that has been registered in the CMC15G is written to the module when the trigger turns ON (or OFF). This function makes it possible to automate the setup of the controller.

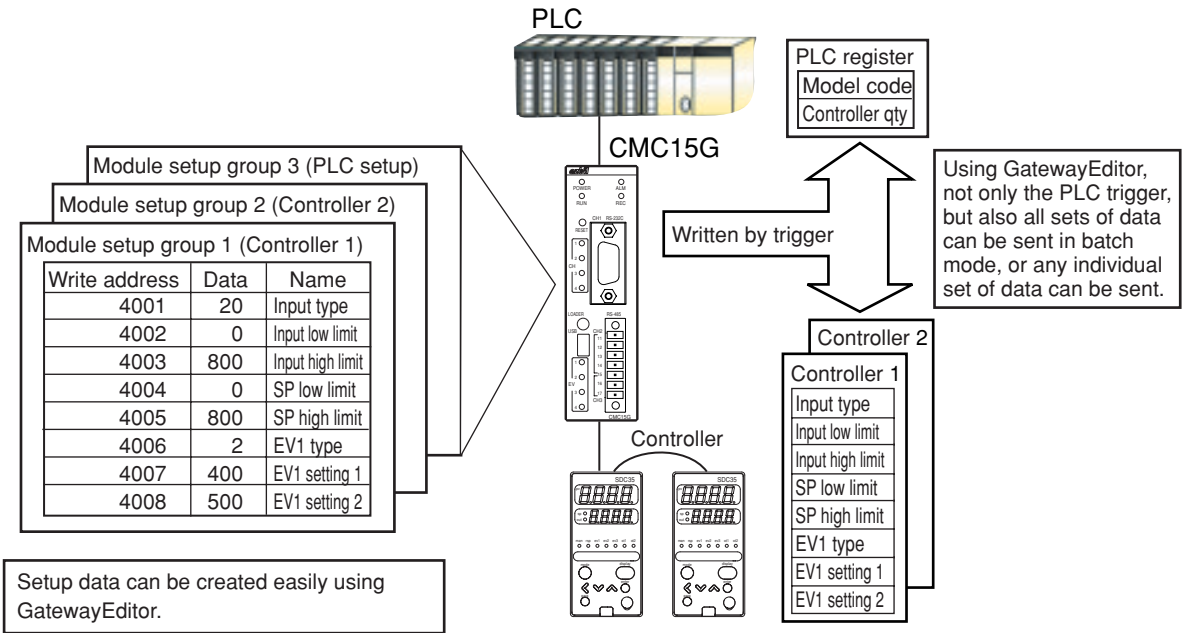

● **Internet event**

Bits or numeric values on the connected modules are monitored in order to turn ON/OFF a corresponding bit inside the CMC15G. This function can be utilized to control whether communications are enabled or disabled, or as the basis for an alarm.

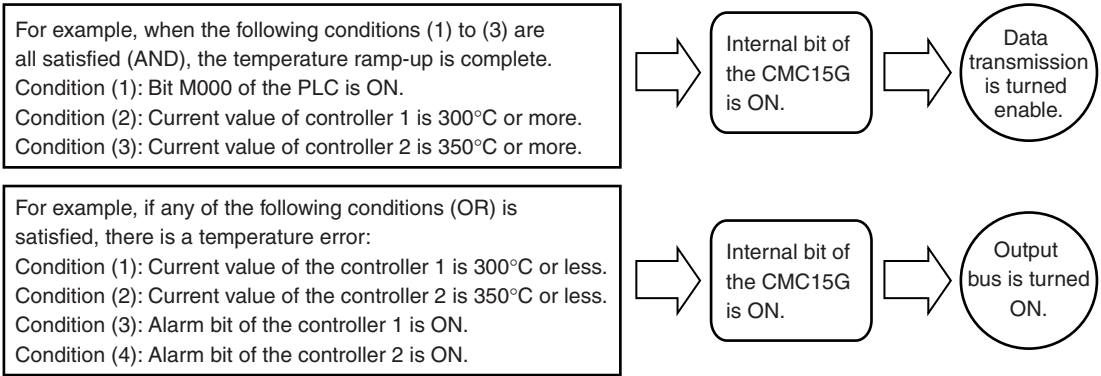

■ Logging function

! Handling Precautions

- To use the logging function, the CMC15GD01 advanced model and the LogViewer (SLP-G15LGV) are required.

● Continuous trend

This function reads numeric data from connected modules at constant intervals and records the data. Data is saved in the internal memory of the CMC15G. This function can be used to monitor, at constant intervals, changes in value.

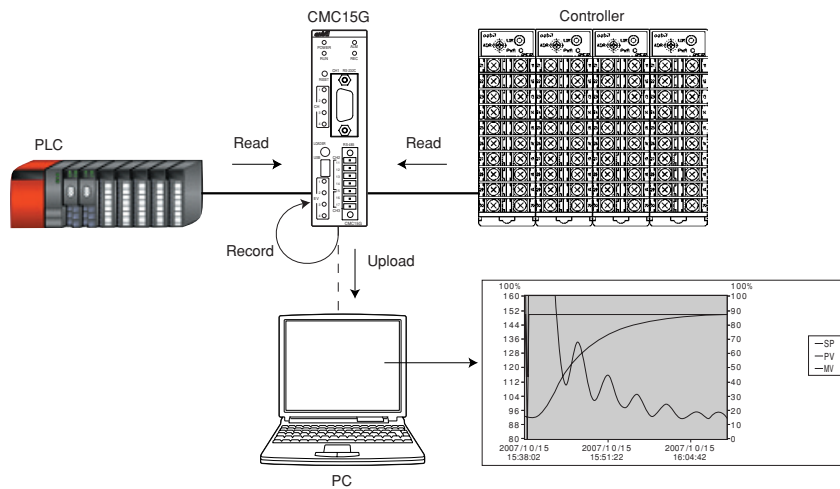

● Captured trends function

This function reads numeric data from connected modules at constant intervals and records the data before and after a trigger occurs. Data is saved in the internal memory of the CMC15G. Numeric data from connected modules can be recorded for a specified period of time before and after an error occurs. This function can be used to retain waveform information before and after an alarm occurs, in order to analyze the information for maintenance purposes.

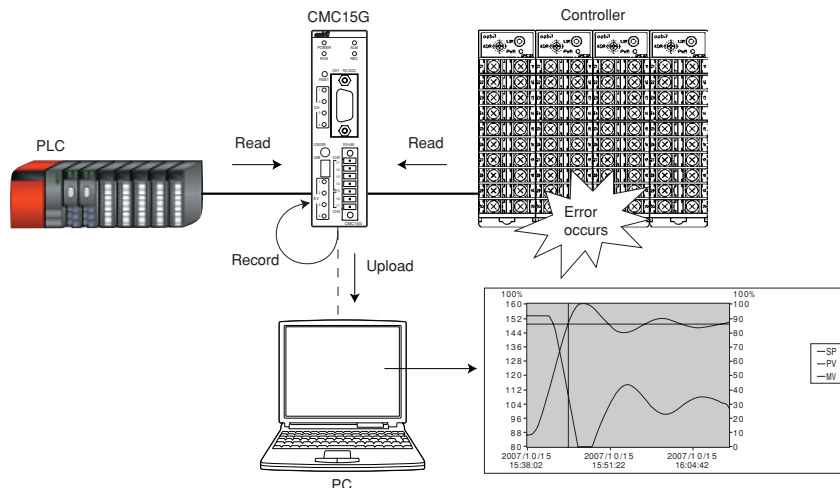

● Data log

This function records data from connected modules in the internal memory of the CMC15G whenever a change in a specified bit occurs. The status data for connected modules for one operation cycle can be saved at a specified time, such as when the system batch process begins, or when an error occurs in a connected module.

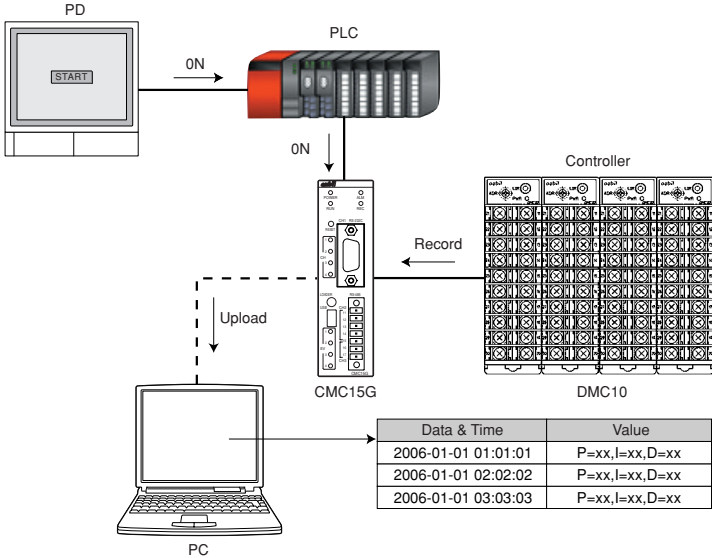

● Event log

This function monitors a specified bit periodically. If any change occurs in the bit, the event type and time are recorded in the internal memory.

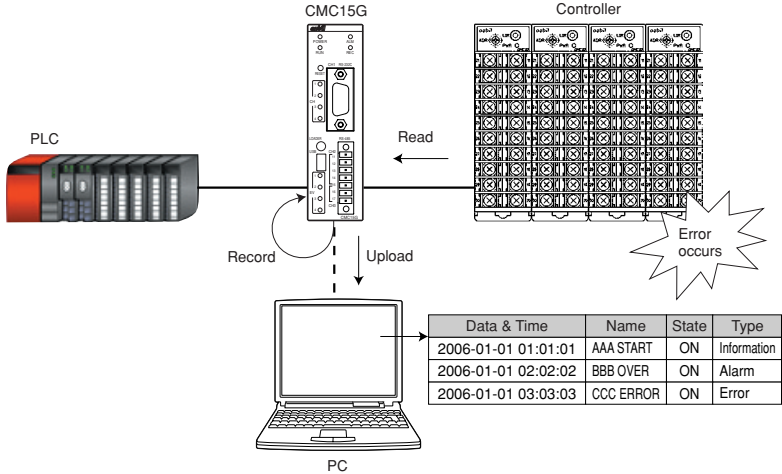

■ Extend functional option configuration

● Extend functions

- Status notification
This function notifies the host station concerning the status of the CMC15G. The user can verify from the host station that no error has occurred in communications between the host station and the CMC15G.
- Communication error notification
If an error occurs in communications with the connected module, this function notifies the host station.
- Date and time adjustment
This function sets the clock of the CMC15G based on the clock data of the host station.

● Option configuration

- Changing a node address
This allows changing of the CMC15G node address used for serial slave station communications.
- Startup delay
The operational start of the CMC15G can be delayed until other connected modules have started up. This can be useful for preventing a communication error when the power is turned ON.
- Trigger device initialization
The trigger for data transmission or device setup can be initialized. This can reduce the load on the host station.
- Initialization of completion notification device and error notification device
A device that transmits the result of communication can be initialized. This can reduce the load on the host station.

■ Digital signal input/output bus

Digital signals to/from the DMC10 can be output/input utilizing the external bus for the DMC10. DMC10 alarms or events can be monitored, and/or a signal acting as external switch bus input for the DMC10 can be used to change its RUN/READY status.

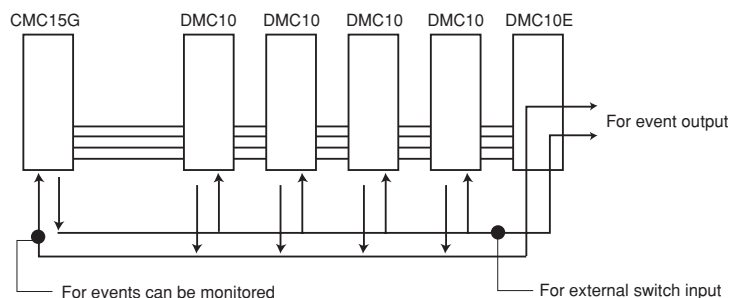

■ Loader through-communication

The loader for a temperature controller can be used through the CMC15G.

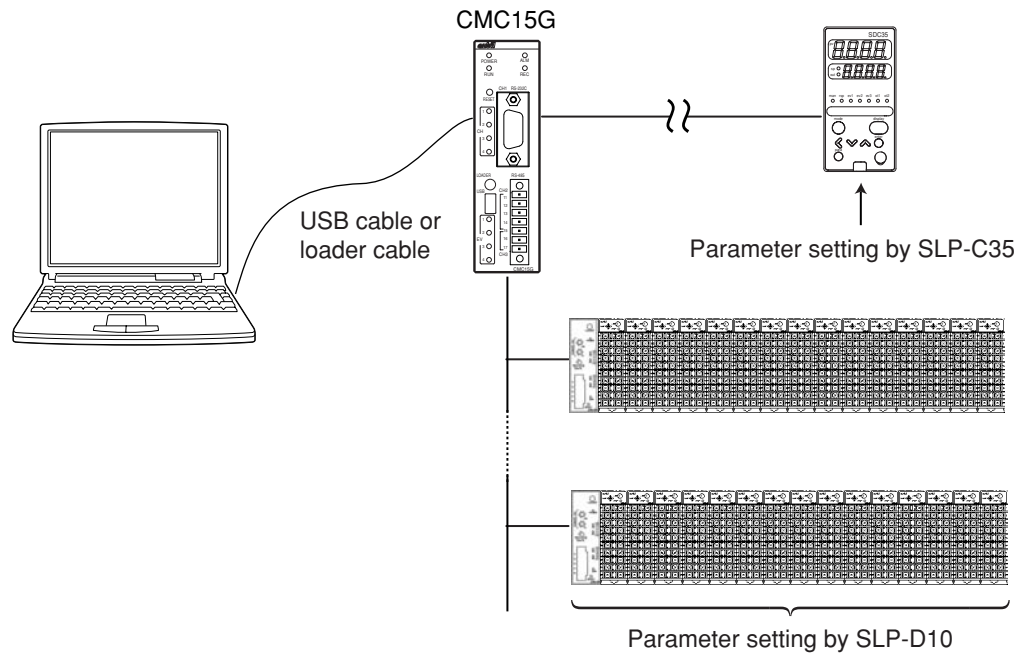

! Handling Precautions

- To execute the loader through-communication, other communication or data collection is stopped and the CMC15G is put in STOP mode.
- Loaders capable of loader-through communications include Yamatake's Smart Loader Package models SLP-D10, SLP-C35, SLP-C45, MLP100, and others.

Chapter 2 PART NAMES AND FUNCTIONS

■ Body

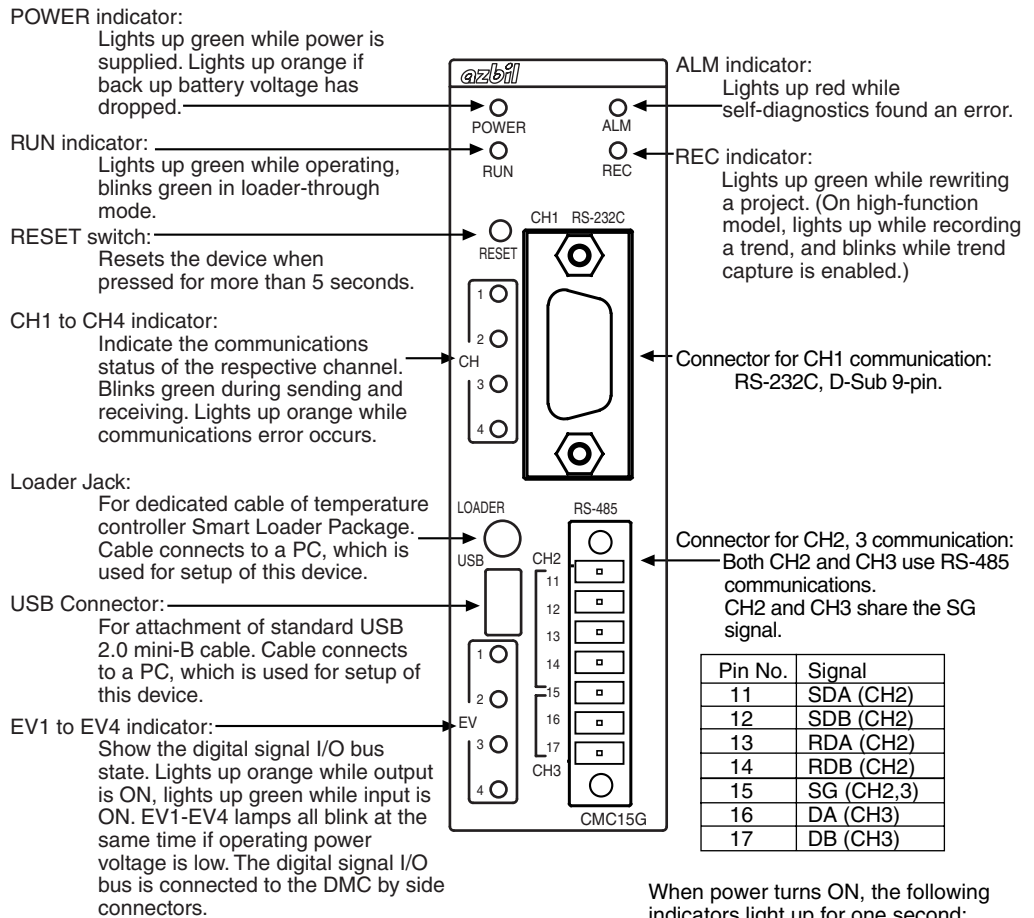

When power turns ON, the following indicators light up for one second:

POWER	Orange
RUN	Green
CH1 to 4	Orange
EV1 to 4	Orange
ALM	Red
REC	Green

■ Base

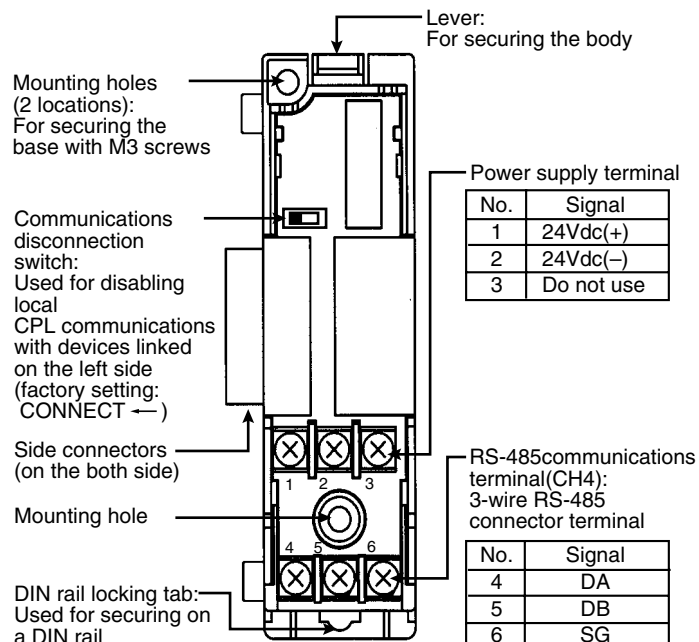

■ Communication ports for module connection

For connection of modules, such as a PLC or controller, the four communication ports described below are available.

☞ Communication Controller CMC15G Multifunction Gateway User's Manual "Communication Connections", CP-SP-1278E (for details about module connection).

● CH1:RS-232C

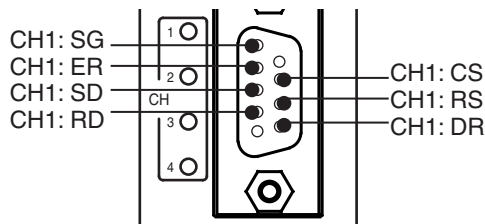

CH1
 RD: Receive data (connected module → CMC15G)
 SD: Send data (CMC15G → connected module)
 ER: (Not used – internal connection with DR pin)
 SG: Signal ground
 DR: (Not used – internal connection with ER pin)
 RS: (Not used – internal connection with CS pin)
 CS: (Not used – internal connection with RS pin)

● CH2: RS-485 (5-wire), CH3: RS-485 (3-wire)

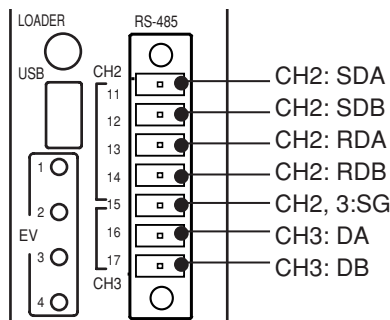

CH2
 SDA: Send data (+) (CMC15G → connected module)
 SDB: Send data (-) (CMC15G → connected module)
 RDA: Receive data (+) (connected module → CMC15G)
 RDB: Receive data (-) (connected module → CMC15G)
 SG: Signal ground

CH3
 DA: Send and receive data (+) (CMC15G ↔ connected module)
 DB: Send and receive data (-) (CMC15G ↔ connected module)
 SG: Signal ground

● CH4: RS-485 (3-wire)

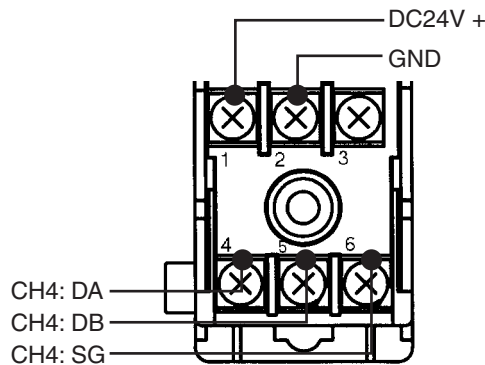

CH4
 DA: Send and receive data (+) (CMC15G ↔ connected module)
 DB: Send and receive data (-) (CMC15G ↔ connected module)
 SG: Signal ground

● Transmission speed

The maximum transmission speed of each communication port is shown in the table on the right.

Max. transmission speed

CH1	115.2kbps
CH2	115.2kbps
CH3	19.2kbps
CH4	38.4kbps

! Handling Precautions

- Connect a terminating resistor (150 Ω, 1/2 W) to CH2.
- Do not connect an external terminating resistor to CH3, since a resistor similar to a terminating resistor is already built in.
- Do not connect an external terminating resistor to CH4, since a resistor similar to a terminating resistor is already built in.

- **PC communication port for**

There are two ways to connect GatewayEditor to the CMC15G.

- USB mini-B connector
- Loader jack

Prior to using the USB connector, it is necessary to install the special device drivers on the personal computer. Installation of the drivers can be done using "setup.exe" on the included GatewayEditor Setup CD-ROM.

 **Handling Precautions**

- Never attempt to use the USB mini-B and loader jack at the same time. Doing so may cause a malfunction.
- Do not connect two or more CMC15G units to one personal computer using USB connectors. Doing so may cause the communication to fail.
- Do not apply unreasonable force to the USB loader jack, or it may break.

- **Digital signal input/output bus for DMC10**

A digital signal can be input or output to/from the DMC10 by utilizing the DMC10's event bus output and external switch bus input. There are four digital signal input/outputs.

 **Note**

- Use of the event output module (the DMC10E) enables use of event output.

 **Handling Precautions**

- The input process delay and output delay of the digital signal may vary depending on the internal processing load.
- When the event bus output from the DMC10 is used for the digital signal input of the CMC15G, the processing load is checked on the online monitor and appropriate measures are taken so that the digital signal input does not change for a period of time twice longer than the processing cycle of the CMC15G.
- The delay time of the digital signal output from the CMC15G may vary depending on the processing load. Allow sufficient time when checking the process on the online monitor.

■ Display unit

● LED indicators for main unit status

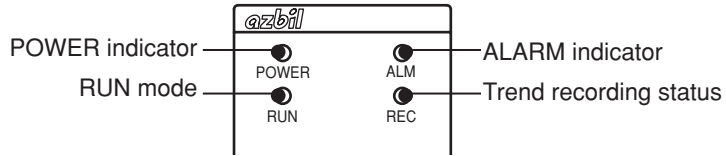

The meaning of the main unit LED indicators is as follows.

● POWER indicator

This indicator is used to check the power supply status of the CMC15G main unit.

Status	Meaning
Off	CMC15G power is OFF.
Green	CMC15G power is ON.
Orange	Backup battery voltage has dropped (replace the backup battery).

☞ Chapter 13, MAINTENANCE (detailed corrective actions for backup battery voltage drop)

● ALARM indicator

This indicator shows the results of self-diagnosis by the CMC15G.

☞ Chapter 15, TROUBLESHOOTING (self-diagnosis errors)

Status	Meaning
Off	Unit is operating correctly
Red	An error was found during self-diagnosis.

● RUN indicator

This indicator shows the current mode of the CMC15G.

Status	Meaning
Off	No CMC15G functions are running.
Flashing green	The loader (SLP, etc.) for the controller is executing through-communication with the slave station through the CMC15G.
Green	CMC15G functions are running.

● REC indicator

This LED indicates whether the CMC15G trend function is recording. It is also lit while project data is being written to the CMC15G's built-in flash ROM.

Status	Meaning
Off	Not recording.
Green	<ul style="list-style-type: none"> Continuous trend or captured trends are recording. Project data is being written.
Flashing green, 1 s intervals	<ul style="list-style-type: none"> A CMC15G function is being recorded. The captured trends function is running after a trigger occurred.
Flashing green, 200 ms intervals	Captured trends function is running but capture memory is full.

● CH1 to CH4 indicators

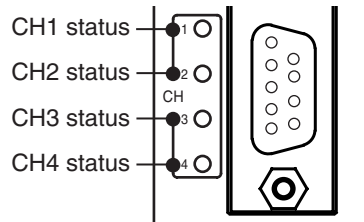

This indicator shows the status of the communication port for connection of the relevant module.

Status	Meaning
Off	No communications.
Flashing green	Communicating
Orange	No response or faulty message received

● EV1 to EV4 indicators

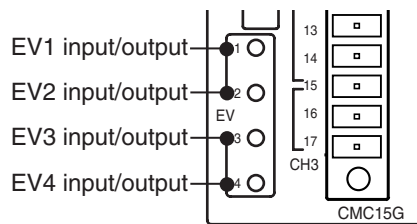

When the DMC10 is connected to the CMC15G, these indicators show the status of the four digital signal inputs and outputs for the event bus outputs and external switch inputs of the DMC10.

Status	Meaning
Off	No digital signal inputs or outputs.
Green	There is a digital signal input.
Orange	There is a digital signal output.
Flashing orange	Power failure.

Power failure indication

If a power failure (supply power voltage drop) occurs, the EV1 to EV4 indicators all flash orange.

● Reset switch

This switch is used to reset the main unit. Press for 5 s or longer with a fine-tip object. Resetting means that the CMC15G is restarted by means of software. Afterwards, the status of each function is the same as it is when the power is first turned ON.

● Communication disconnection switch

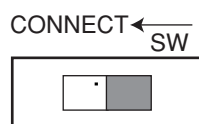

This switch is used to disable RS-485 communications with the module connected through the CH4 connector located on the left of the communication controller main unit. The factory setting is "CONNECT" (communication enabled).

■ Backup battery

The diagram below shows the appearance of the main unit when viewed from the mounting base.

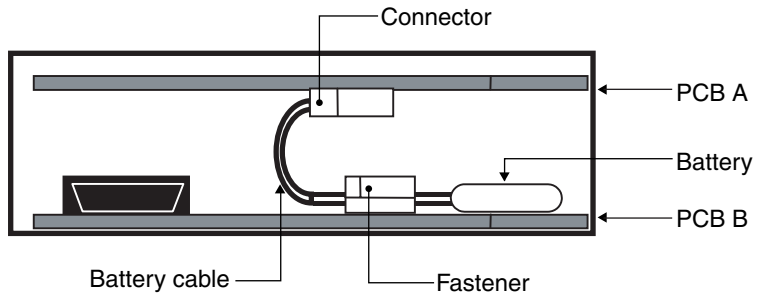

When the power is turned OFF, the backup battery maintains the items shown below.

- Calendar clock
- Backup memory
- System history
- Logging function data

➡ Chapter 13, MAINTENANCE (details on backup battery replacement)

Chapter 3 MOUNTING

■ Mounting locations

Avoid installing the CMC15G in the following locations:

- Locations subject to high and low temperature, high and low humidity exceeding the specified ranges
- Locations subject to corrosive gases such as sulfide gases
- Locations subject to dust or oil fume
- Locations subject to direct sunlight, wind or rain
- Locations subject to vibration or shock exceeding the specified ranges
- Locations under high-voltage lines and near sources of electrical noise such as welders
- Locations within 15 meters of high-voltage ignition equipment such as boilers
- Locations where magnetic fields are generated
- Locations near flammable liquid or steam

■ Linking modules

The CMC15G can be linked with other modules by the connectors on the left and right of the base.

Modules must be linked before the CMC15G is mounted on the DIN rail or mounted by screws.

By linking modules together, the power supply of each module and RS-485 (CH4) communications are connected, eliminating the need for wiring.

RS-485 (CH4) communications can be disconnected by the communications disconnection switch located on the base.

■ Mounting method

The CMC15G base can be mounted either by screws or by attachment to a DIN rail.

! Handling Precautions

- Install this module so that it is vertical, with the DIN rail locking tab at the bottom.

● When mounting the base by screws

Secure the two mounting holes on the base by M3 screws.

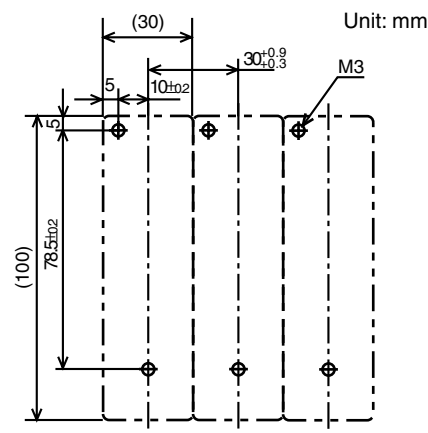

● **When securing on a DIN rail**

Secure the base on the DIN rail, fully draw out the DIN rail locking tab and hook the base onto the DIN rail. Next, push the DIN rail locking tab upwards until you hear it click into place.

■ **Mounting the body on the base**

Please the hook into the base and push the body into the base until you hear it click into place.

To remove the body from the base, pull the body towards you while pressing down the lever.

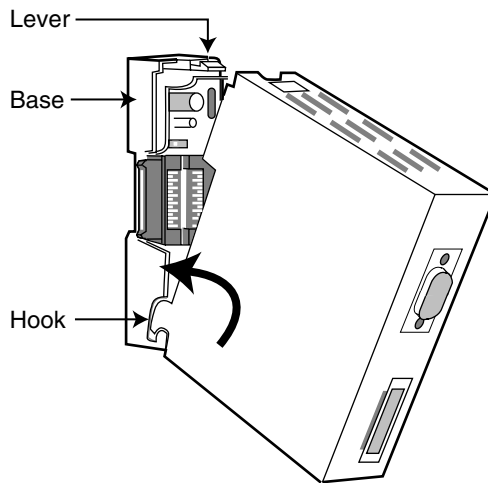

Chapter 4 WIRING

■ Recommended cable

- Use shielded polyethylene insulated vinyl sheathed instrumentation cable for RS-485 input/output and power supply.
- If electromagnetic induction is comparatively low, a shielded multi-core microphone cord (MVVS) can be used.
- Use shielded cable for RS-232C input/output.

Fujikura Ltd.	2 conductors	IPEV-S-0.9mm ² X1P
	3 conductors	ITEV-S-0.9mm ² X1T
Hitachi Cable, Ltd.	2 conductors	KTEV-S-0.9mm ² X1T
	3 conductors	KPEV-S-0.9mm ² X1P

■ Wiring precautions

Be sure to use crimped terminals for wiring terminals. When wiring is finished, check the connections for any miswiring before turning the power ON.

■ Connecting the power supply

Connect the 24Vdc power supply to terminals (1) and (2) on the base.

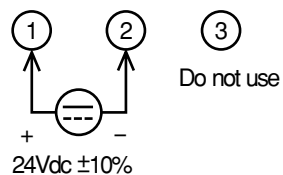

⚠ Handling Precautions

- Power is mutually connected between linked modules. Supply power to one of the linked modules.
- Select a power supply that can cover the total power consumption of all linked modules. Select a power supply that can cover the total power consumption of all linked modules. If the total power supply is insufficient, EV1 to EV4 indicators blink in sync.
- If the power supply capacity is insufficient, the voltage will be too low, resulting in blinking of EV1 to EV4, or repeated resetting.

■ Connecting for CH1 communications (RS-232C)

Connect the cable to the D-Sub 9-pin connector on the CMC15G.

Pin No.	Signal	Contents
1 *1	CD	Not used
2	RD	Receive data (connected module → CMC15G)
3	SD	Send data (CMC15G → connected module)
4 *1	ER	Not used
5	SG	Signal ground
6 *1	DR	Not used
7 *2	RS	Not used
8 *2	CS	Not used
9	CI	Not used

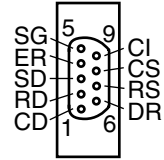

- *1 Pins 1, 4 and 6 are connected to each other internally.
- *2 Pins 7 and 8 are connected internally.

■ Connecting for CH2 communications (RS-485)

This channel is for a 5-wire or 3-wire RS-485 connection. The connector for this interface is attached. Connect the terminating resistor (150Ω, 1/2W).

Pin No.	Signal	Contents
11	SDA	Send data (+) (CMC15G → connected module)
12	SDB	Send data (-) (CMC15G → connected module)
13	RDA	Receive data (+) (connected module → CMC15G)
14	RDB	Receive data (-) (connected module → CMC15G)
15	SG	Signal ground

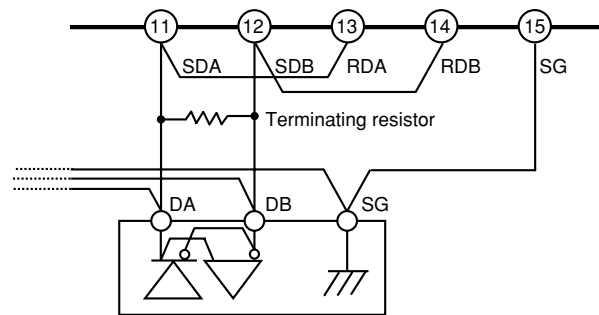

Example: connecting to 3-wire product

! Handling Precautions

- Be sure to connect SG terminals each other. Failure to do so might cause unstable communications.

■ Connecting for CH3 communications (RS-485)

This channel is for a 3-wire RS-485 connection. The connector for this interface is attached. This is shared with CH2.

Pin No.	Signal	Contents
15	SG	Signal ground
16	DA	Send and received data (+) (CMC15G ↔ connected module)
17	DB	Send and received data (-) (CMC15G ↔ connected module)

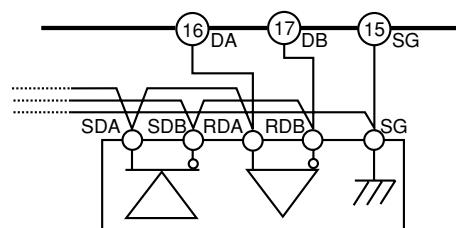

Example: connecting to 5-wire product

[!] Handling Precautions

- Do not additionally connect a terminating resistor because an equivalent resistor has been already built in for CH3. Therefore, even if other instrument used in combination requests a terminating resistor, never connect such resistor externally.
- Be sure to connect SG terminals each other. Failure to do so might cause unstable communications.

■ Connecting for CH4 communications (RS-485)

This channel is for a 3-wire RS-485 connection. This interface is connecting to the terminal of base.

Pin No.	Signal	Contents
4	DA	Send and received data (+) (CMC15G ↔ connected module)
5	DB	Send and received data (-) (CMC15G ↔ connected module)
6	SG	Signal ground

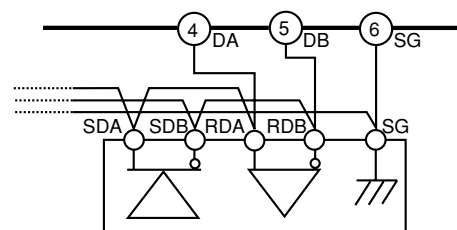

Example: connecting to 5-wire product

[!] Handling Precautions

- Do not additionally connect a terminating resistor because an equivalent resistor has been already built in for CH4. Therefore, even if the instructions for another connected device say to install a terminating resistor, do not do so.
- Be sure to connect SG terminals each other. Failure to do so might cause unstable communications

■ Device connections and configuration**● Number of connected units**

A maximum of 31 units can be directly connected to the device communication ports on each of CH2, CH3, and CH4.

[!] Handling Precautions

- When used with the DMC10, a maximum of 15 units can be directly connected, due to the limitation of the rotary switch.

● When connecting 31 or more units

To connect more than 31 Yamatake devices to each channel, the CMC10B communication controller (CPL/CPL converter, sold separately) is required.

[!] Handling Precautions

- The number of connected units refers to the number of units that can be connected electrically. In this kind of connection, you must check whether or not the transmission speed is suited to the required level in the application. Consult a Yamatake sales agent.
- Event output module DMC10E is not included in the number of connected units.

■ Setting the device address

The device address must be set to the unit in order to use the unit.
Set the device address as follows:

! Handling Precautions

- The same device address number cannot be used on the same channel. For the devices connected to the same channel, be sure to use a different device address.

Setup example

Address of device (1) connected to CH3: 1

Address of device (2) connected to CH3: 2

Address of device (3) connected to CH4: 2

Address of device (4) connected to CH4: 3

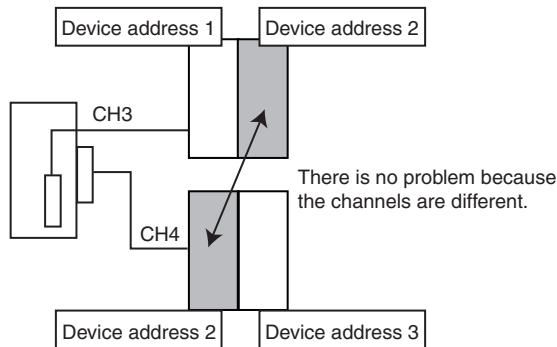

● Connection of Yamatake devices through the CMC10B

It is necessary also to set up a device address for each device connected through the CMC10B. These addresses are handled as sub-addresses by the CMC15G.

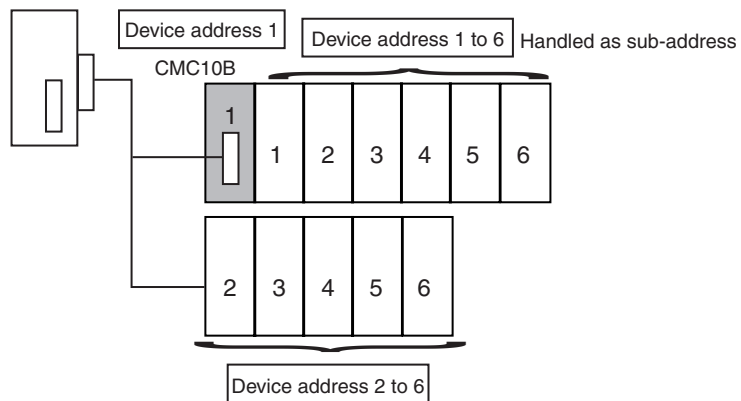

! Handling Precautions

- Be sure to set the device address of DMC10s connected to the same CMC10B to unique values.
- The same device address can be used when a DMC10 is connected to different CMC10Bs.

☞ Communications Controller CMC10B (CPL/CPL Converter) separate Instruction Manual, Design Manual CP-SP-1064E (for details on CMC10B settings).

● Layout of event output module DMC10E

Only one event output module DMC10E can be used within a group linked by connectors. When the connection is made by wiring from the bases without using the side connectors as shown below, each group is independent and a new event output module can be used.

! Handling Precautions

- Within a single group of units connected by side connectors, there can be only one event output module by which output can be done from the CMC15G.

● Position of event output module

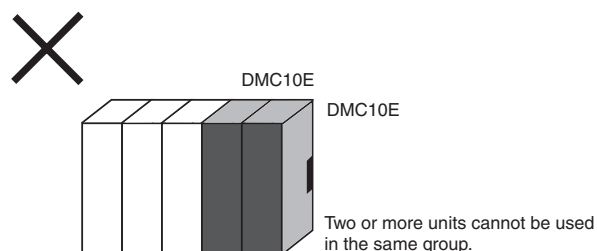
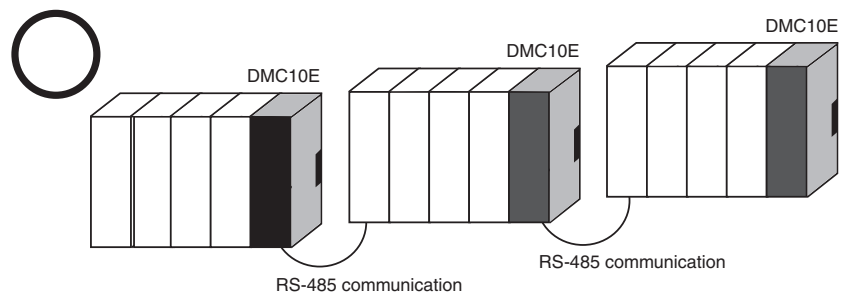

The event output module DMC10E can be positioned anywhere within a linked group.

Chapter 5 BASIC FUNCTIONS

5 - 1 Data Transmission

This data transmission function exchanges data among modules connected to the CMC15G.

Data is read from slave stations (controllers, etc.) periodically and written to the host station (PLC, etc.), or else data from the host station is written to the slave stations upon activation of a trigger at the host station.

Accordingly, there are two execution methods, cyclic execution and trigger execution.

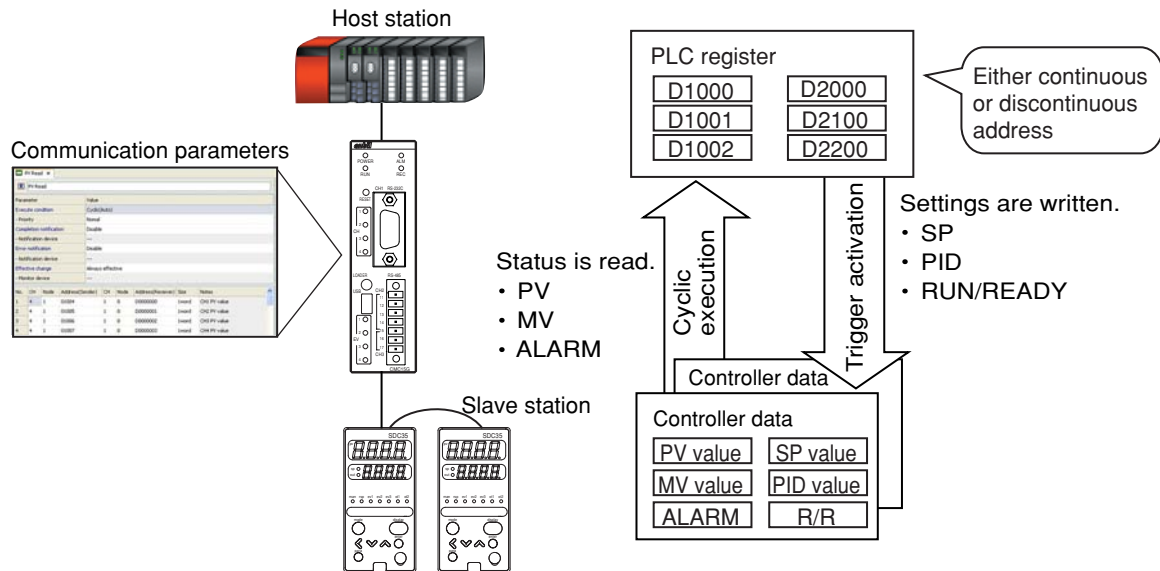

■ Cyclic execution

This cyclic execution function reads data from connected modules periodically and writes the data to another specified module.

This function is used when, for example, the host station monitors the slave station data at constant intervals.

Major applications

- Information from slave stations is shown on a display unit connected to the host station.
- Information from slave stations is recorded at the host station.
- Information from slave stations is utilized to control the host station.

● **Description of operation**

Cyclic execution begins at constant intervals. There are two startup methods, cyclic (auto) and cyclic (fixed).

- Cyclic (auto): The CMC15G determines an execution interval based on the average processing time.
- Cyclic (fixed): Cyclic execution begins at user-specified intervals.

● **Process**

The following describes the process when the CMC15G transmits data from the slave station to the host station periodically.

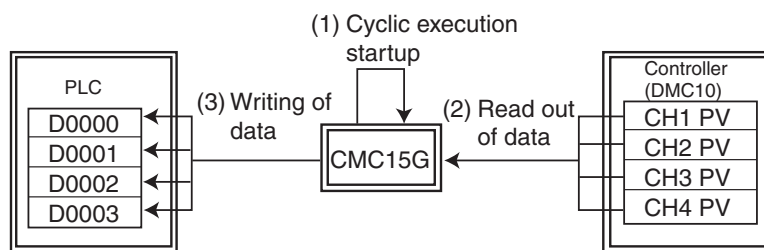

- (1) Execution occurs in cycles specified by CMC15G settings.
- (2) Data is read from the source.
- (3) The data is written to the destination.

● **Operation if an error occurs**

- If a process is not completed within the specified cycle, special contact SM901.0 (cycle overrun) inside the CMC15G turns ON. Note that the incomplete process is not restarted.

➡ Chapter 12, CONTACTS AND REGISTERS INSIDE THE CMC15G

- If a communication error occurs when reading data from the source, the data containing the error is not written. Processing of other lines (subsequent data) is executed. If error notification has been specified, notification of process completion and of the error is sent to the host station after all processes have been completed.

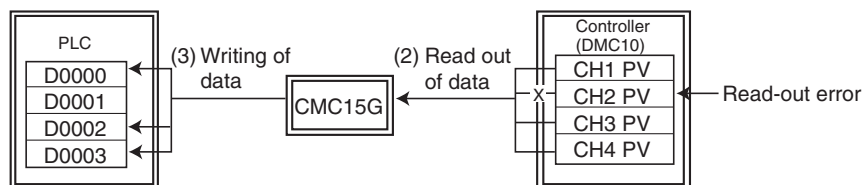

If a communication error occurs when reading the PV from CH2 of the DMC10, the error data is not written to D0001 on the PLC.

- If a communication error occurs when writing data, the processing of other lines (subsequent data) is executed. If error notification has been specified, notification of process completion and of the error is sent to the host station after all processes have been completed.

■ Triggers

The trigger function reads data from connected modules and writes it to the specified modules when a change in the trigger device (for example, a bit) is detected. Triggers are used to control the slave station on the basis of host station instructions or status. The major applications are:

- Changing the operation status (RUN/READY) of a slave station by the host station.
- Changing the settings (SP value, PID setting, etc.) of a slave station by the host station.

A trigger operates if a change in the trigger device on a specified connected module is detected. There are two kinds of triggers, trigger (OFF→ON) and trigger (ON→OFF).

- Trigger (OFF→ON): Executed when the value of a specified bit is changed from OFF to ON.
- Trigger (ON→OFF): Executed when the value of a specified bit is changed from ON to OFF.

● Process

The following describes the operation when the data of the host station is transmitted to a slave station if the specified trigger device on the host station is changed from OFF to ON:

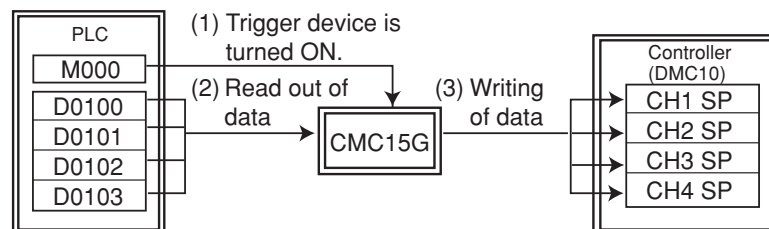

(1) The CMC15G monitors the trigger device periodically. After the trigger device is turned ON, the trigger is executed.

(2) Data is read from the source.

(3) The data is written to the destination.

📖 Note

- If the data type of the trigger device is a word, changes in value are judged according to the contents of bit 0 (the least significant bit).



Additionally, the bit that is initialized by trigger device initialization is bit 0 (the LSB) only.

● **Operation if an error occurs**

- If a communication error occurs when reading the trigger device, the trigger is not activated.
- If a communication error occurs when reading the data, the write process is not executed, but the processing of other lines (subsequent data) is executed. If error notification has been specified, notification of process completion and of the error is sent to the host station after all processes have been completed.
- If a communication error occurs when writing the data, the process of other lines (subsequent data) is executed. If error notification has been specified, notification of process completion and of the error is sent to the host station after all processes have been completed.

5 - 2 Module Setup

This function writes fixed data (values stored in the CMC15G) to connected modules. It can be used, upon instructions from the host station, for tasks such as changing the mode (RUN/READY) of a controller or other slave station or initializing the settings of a connected module.

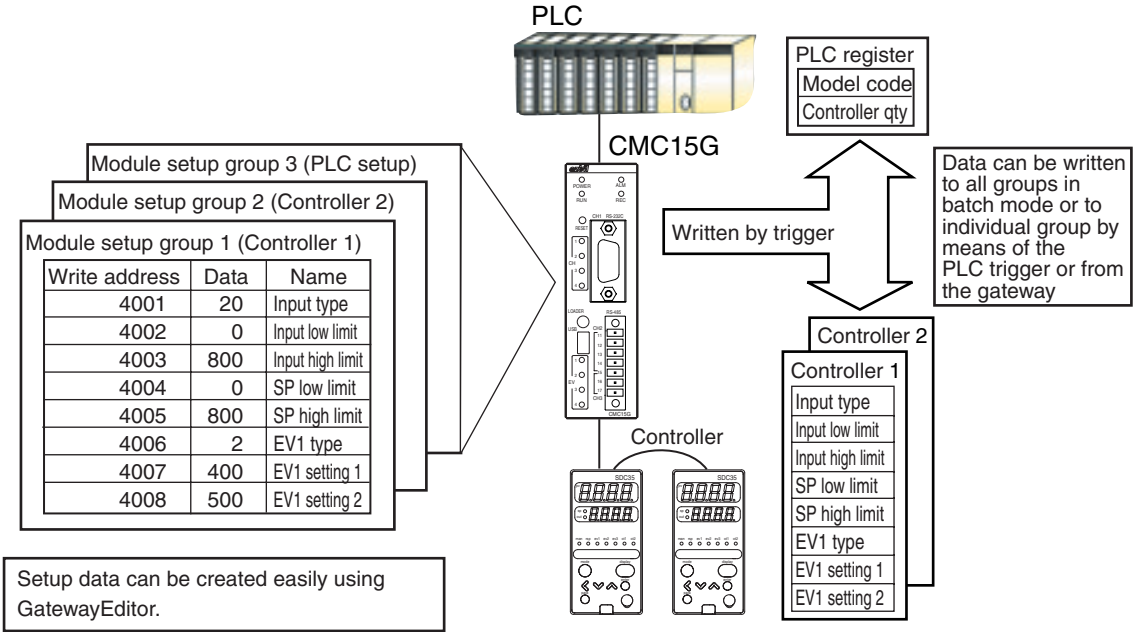

Major applications

- Setup of initial values on connected modules.
- Changing the mode (RUN/READY) of connected modules in a single operation.
- Writing of operation parameters by product type to connected modules in batch mode.

■ Triggers

If a change in the trigger device of a specified connected module is detected, data is written to the specified memory location on the connected module.

There are two kinds of trigger, as described below.

Trigger (OFF→ON): Executed when the value of a specified trigger device is changed from OFF to ON.

Trigger (ON→OFF): Executed when the value of a specified trigger device is changed from ON to OFF.

● Process

The following describes the operation to write the initial values (data) set for the CMC15G to a connected module when the specified trigger device on the host station is changed from OFF to ON:

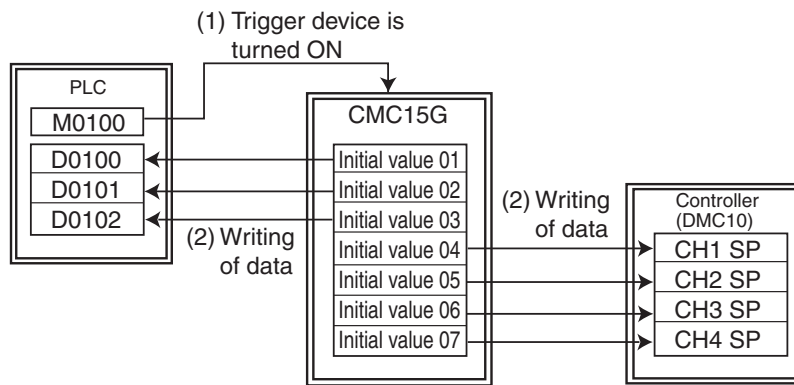

(1) The CMC15G monitors the trigger device periodically. After the trigger device is turned ON, the trigger is executed.

(2) The initial values (data) stored on the CMC15G are written to a destination.

📖 Note

- If the data type of the trigger device is a word, changes in value are judged according to the contents of bit 0 (the least significant bit).



Additionally, the bit that is initialized by trigger device initialization is bit 0 (the LSB) only.

● Operation if an error occurs

- If a communication error occurs when reading the trigger device, the trigger is not activated.
- If a communication error occurs during writing, if error notification has been specified, notification of process completion and of the occurrence of the error are sent to the host station after all processes have been completed. If the communication error occurs while further processing remains to be done, the processing of other lines (subsequent data) is executed.

5 - 3 Internal Event

This internal event function monitors the status of a bit or numeric value on a connected module in order to determine whether to turn ON or OFF a corresponding bit inside the CMC15G. The information output to the internal bit can be utilized for locations shown below.

- The enabled-disabled setting for various functions
- Trigger device for various functions

■ Cyclic execution

There are two kinds of startup methods, cyclic (auto) and cyclic (fixed), as described below.

- Cyclic (auto): The CMC15G determines an execution interval from the average processing time.
- Cyclic (fixed): The cyclic execution is started up at set intervals (in "s" (seconds)).

● Process

Multiple specified devices registered in the process are monitored periodically. A specified internal event device (EM00*.*) is turned ON while all conditions are satisfied (AND condition) or any condition is satisfied (OR condition) in the status of the read-out device.

The following describes the process when the PV value of the controller is read out periodically, this range is monitored, and the internal event device is set if the read out value is beyond the range:

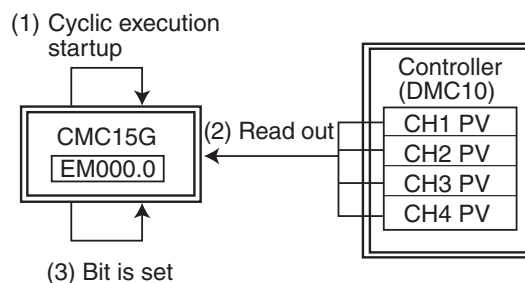

- (1) The cyclic execution is started at intervals specified inside the CMC15G.
- (2) The numeric value data is read out from a specified address.
- (3) If any numeric value data is beyond a specified range, the internal event device (EM000.0) is turned ON.

● Operation if an error occurs

- If a process is not completed within the specified cycle, special contact SM901.0 (cycle overrun) inside the CMC15G turns ON.
 ➔ Chapter 12, CONTACTS AND REGISTERS INSIDE THE CMC15G
- If the communication error occurs in the read-out process, the internal event device at the output destination is not changed.

5 - 4 Group

■ Group

Basic functions and logging functions can be registered to function-related processing groups. A group is a processing unit that contains a series of processes with common startup conditions or processing details. The following table gives the maximum number of groups per function and the number of records that can be processed by one group.

Function		Max. number of groups	Max. number of data records inside group
Basic functions	Data transmission	200	100
	Module setup	200	100
	Internal event	20	20

For example, up to 100 data items (data to be exchanged between the PLC and controller) and up to 200 groups can be registered for data transmission.

However, note that the total number of data items (number of groups by function × number of data records) cannot exceed 20,000.

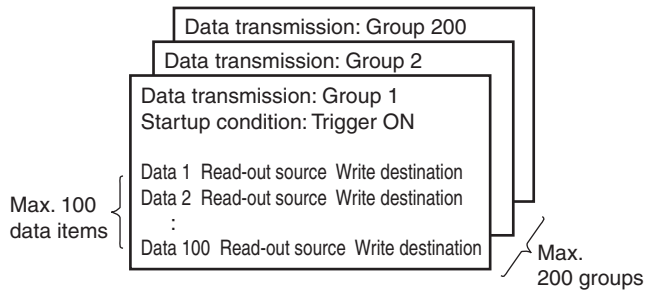

5 - 5 Execution Conditions and Processing for Each Function

The following shows the available startup conditions and processing for each function.

Function		Startup condition		Enabled-disabled setting	Sequential execution	Notification process
		Cycle	Trigger			
Basic functions	Data transmission	○	○	○	○	○
	Module setup	×	○	○	○	○
	Internal event	○	×	○	×	×

○: Available ×: Not available

■ Execution conditions

Execution is either cyclic or by trigger.

● Cyclic execution

Cyclic execution operates continuously at specified intervals.

There are two kinds of cyclic execution, auto and fixed.

- Cyclic (auto): The CMC15G determines an execution interval based on the average processing time.
- Cyclic (fixed): Cyclic execution begins at intervals specified by the user (in "s" (seconds)).

📖 Note

- If a process is not completed within the specified cycle, special contact SM901.0 (cycle overrun) inside the CMC15G turns ON. Note that the process is not restarted.

👉 Chapter 12, CONTACTS AND REGISTERS INSIDE THE CMC15G

Cyclic (auto) ensures efficient communication with little waste. PV values or alarms are read at high speed, and other values such as SP or PID are read at standard speed. Data having a low urgency level is assigned to a fixed cycle in "m" (minutes) or "h" (hours).

Since cycles are classified by their priority, the overall communications performance can be improved.

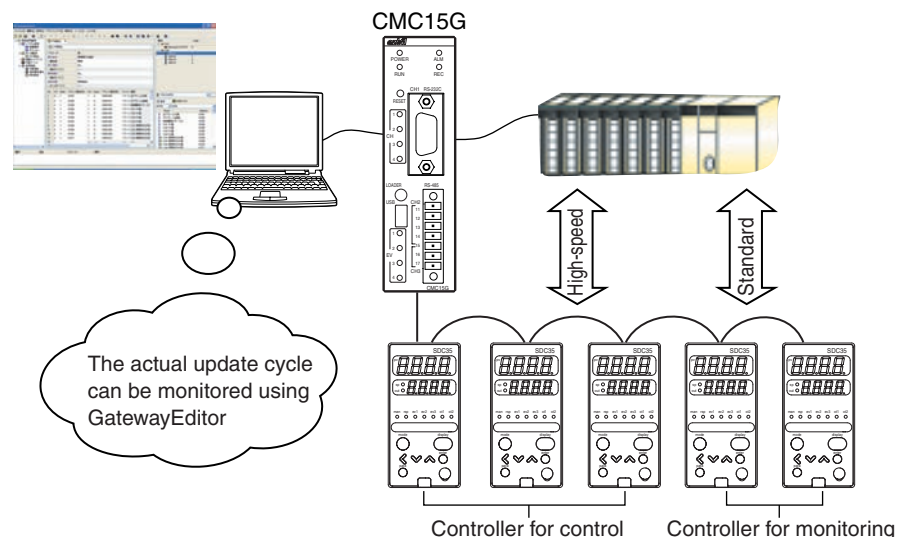

● **Triggers**

Triggers are activated when a change in the trigger device of a specified connected module is detected.

Trigger (OFF→ON): Executed when the value of a specified trigger device is changed from OFF to ON.

Trigger (ON→OFF): Executed when the value of a specified trigger device is changed from ON to OFF.

 **Note**

- The trigger device specified by the trigger is never read while processing of the group is in progress. If the trigger device changes during execution, it is ignored.

The trigger device can be initialized before starting processing of the group.

 ● **Trigger device initialization (on page 9-14).**

- If the data type of the trigger device is a word, changes in value are judged according to the contents of bit 0 (the least significant bit).



Additionally, the bit that is initialized by trigger device initialization is bit 0 (the LSB) only.

 **Handling Precautions**

- If an error occurs in the trigger device readout process, the group is not started up.

■ **Enabled-disabled setting**

If, because of conditions, you do not want to execute a processing group that has been started, you can stop the group execution by changing this setting.

Three choices are available:

- Always effective: The process is always enabled.
- Effective at bit status ON: The process is enabled if the specified bit of a connected module is ON.
- Effective at bit status OFF: The process is enabled if the specified bit of a connected module is OFF.

 **Note**

- The initial value is "Always effective."
- When "Effective at bit status ON" or "Effective at bit status OFF" is set, the specified bit is read immediately after startup.
- If an error occurs while reading the specified bit, the operation enters the "waiting for startup" status as if it were disabled.

The enabled-disabled setting can be utilized for applications described below.

By setting groups by controller, you can specify enabled or disabled status by individual controller, so as to perform the following operations:

- Share application software used for the system.
- Take only specific controllers offline.

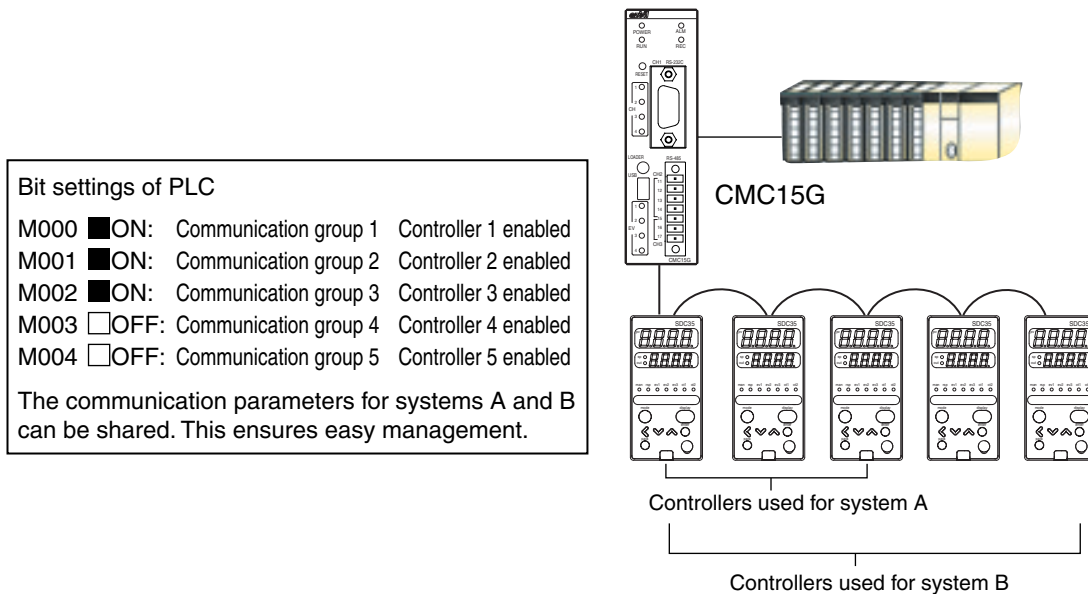

■ Sequential execution

After processing begins, this function sequentially executes each process while accomplishing the completion of each cohesive process class designated for sequential processing.

This function can be used only when transmitting data or setting up a module.

It is used if the process order is already determined when the set values are written to the slave station.

Click the line No. of a line you want to synchronize and press the right mouse button to select [Insert sync line (Y)], or input "SYNC" (1-byte uppercase characters) in the "CH" cell (left end).

• Application example of data transmission

This sequential execution function is used when the writing order of the values is already determined.

The figure below shows an example in which controller operation is stopped (the controller is put in READY mode) by instructions given from the PLC, and then the controller is returned to RUN status after the data has been transmitted.

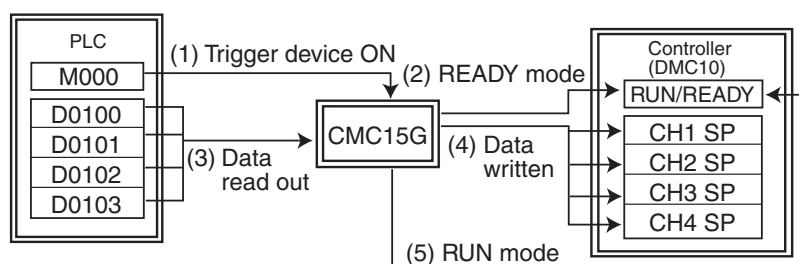

- Operation flow

- (1) The CMC15G monitors the bit periodically. If the bit is changed to ON, the sequential execution function is started.
- (2) The READY constant is written to the RUN/READY address.
- (3) The data is read from the source after step (2) has been completed.
- (4) The read out data is written to the write destination.
- (5) The RUN constant is written to the RUN/READY address after all processes in steps (3) and (4) have been completed.

- **Application example of module setup**

In the example below, upon instructions from the PLC, the controller is stopped temporarily (READY status), initial settings stored on the CMC15G are written, and the controller resumes operation (RUN status).

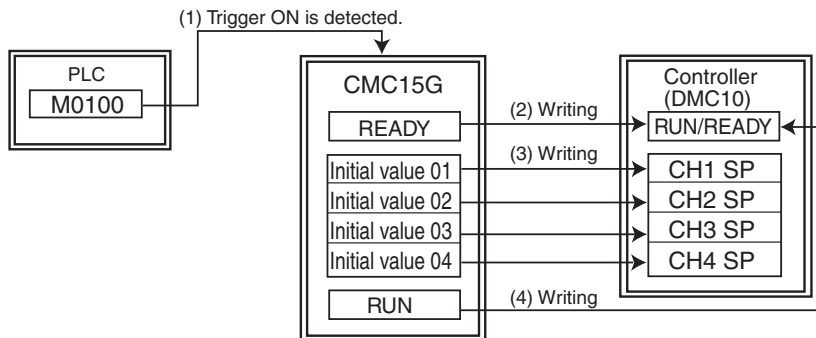

- Operation flow

- (1) The CMC15G monitors the bit periodically. If the bit is changed to ON, the sequential execution function is started.
- (2) The READY constant is written to the RUN/READY address.
- (3) The initial values stored on the CMC15G are written to the write destination after step (2) has been completed.
- (4) The RUN constant is written to the RUN/READY address after step (3) has been completed.

■ Notification process

This function notifies the host station of processing status. There are two kinds of notification process functions, completion notification and error notification. The notification process can be used only for data transmission or module setup.

● Completion notification

Completion notification turns on a bit of a specified connected module after the processing in the groups for each function has been completed. The completion notification is utilized to check that processing by the trigger has been completed.

● Error notification

Error notification turns on the bit of a specified connected module if a communication error (retry-out or error response) occurs in the process within the group of each function. The error notification function is utilized to check that the processing in the groups for each function has been executed correctly.

Note

- "Completion notification" is sent even if an error occurs while processing. At the start of processing, the bits for completion notification and error notification can be initialized.

 ● Notification device initialization (on page 9-14).

- Notification timing
 - Execution timing during cyclic execution

When set for notification (without initialization) of completion and errors

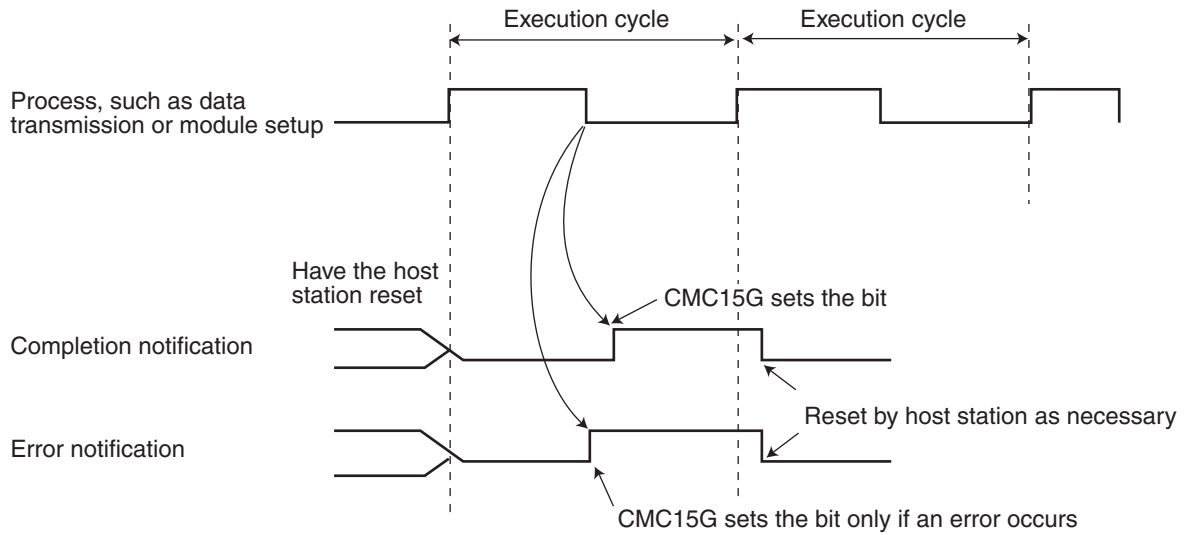

When set for notification (with initialization) of completion and errors

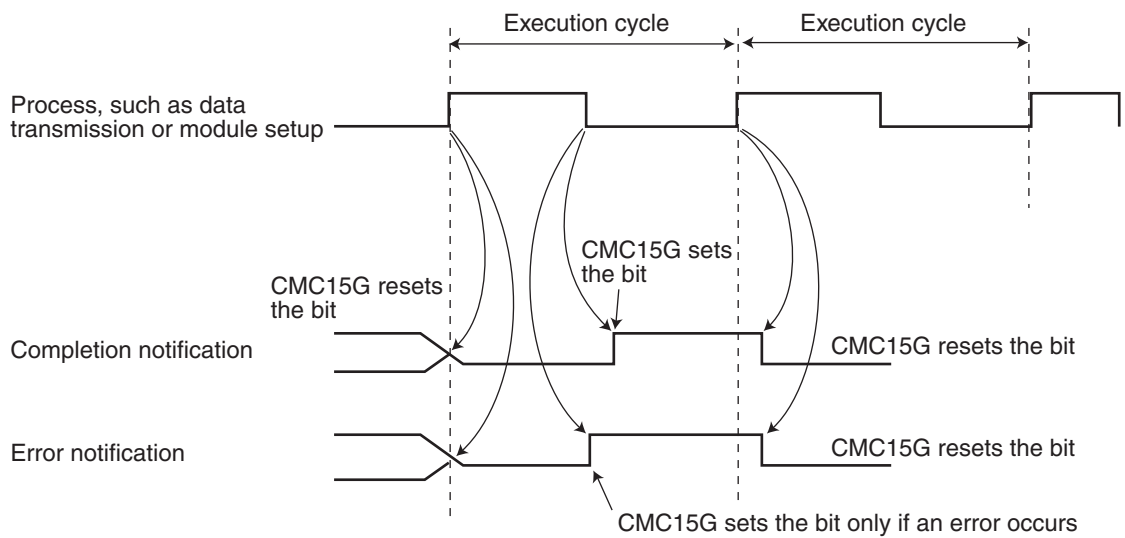

• Execution timing when trigger is started up

Trigger (with initialization), log entry at trigger start, notification (without initialization) of completion and errors

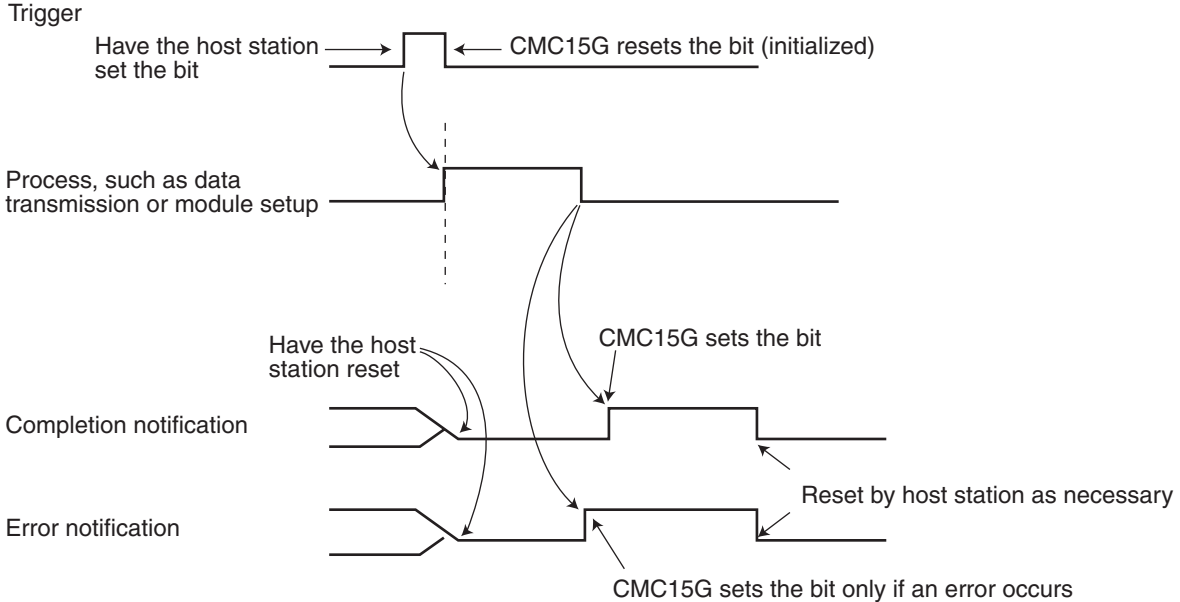

Note: After the trigger (without initialization) is turned ON, it must be turned OFF by the host station.

Trigger (with initialization), log entry at trigger start, notification (with initialization) of completion and errors

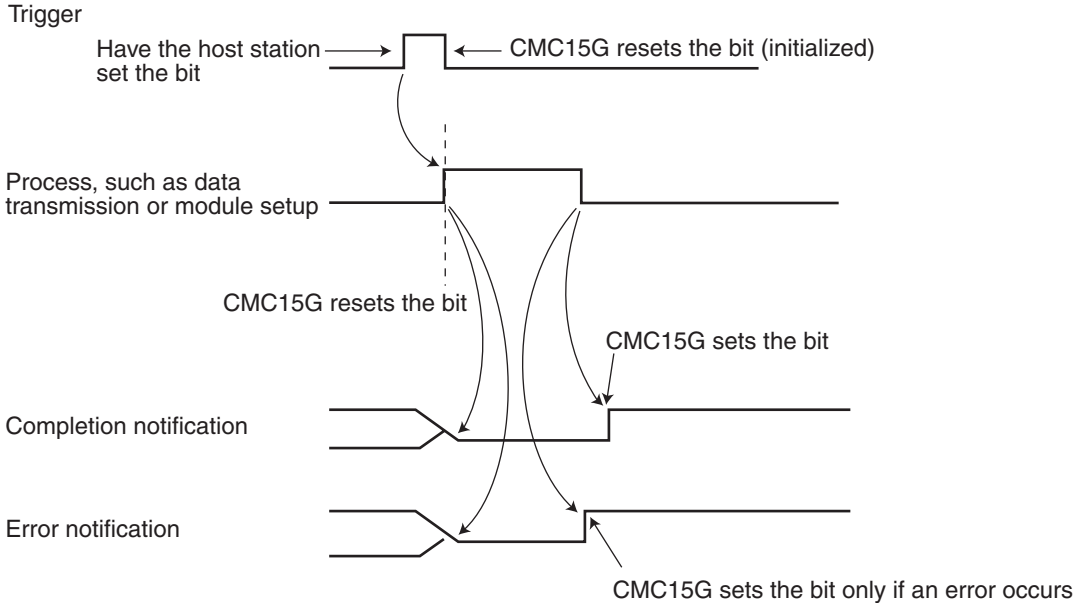

! Handling Precautions

- When using a trigger (with initialization), you must set the trigger device once through the host station (such as a PLC). If a device that is always running, such as an output coil, is used the trigger cannot be initialized by the CMC15G.

○ Correct example

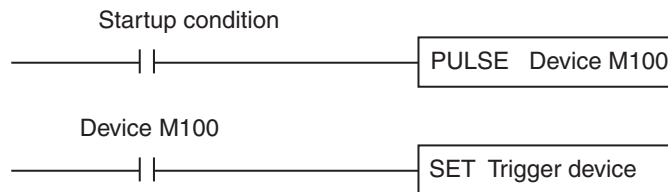

× Incorrect example

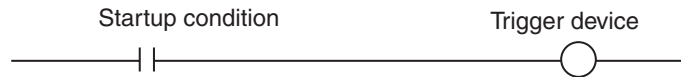

- Multiple groups using the same trigger device
Initialization of the trigger device must not be enabled. If it is, groups may not detect a change in the trigger device, depending on the trigger initialization timing.
- Special contacts (SM900.0 to SM999.F) used as a trigger device
Initialization of the trigger device must not be enabled. If it is, initialization of the trigger device will be judged to have failed and the process will not be executed, since the data writing process will be prohibited. Even if the internal event memory (EM) has not failed, the initialization is not actually done.

5 - 6 Communication Error

■ Occurrence of communication error

The following describes the kinds of communication errors:

Error type	Description
Retry-out	A retry-out error occurs if no response is received from connected modules even though a period of time (time-out time × (number of retry cycles) + 1 (first cycle)) has elapsed. You can specify the desired time-out time and number of retry cycles for each communication channel.
Communication frame error	This error occurs if there is a transmission error (check code error, parity error, overrun, or framing error) or logical error (illegal data) in the response from connected modules.
Error response	This error occurs if the response from connected modules is an error code.

■ Operation if there is a communication error

If a communication error occurs, the occurrence is recorded in the communication error section of the system history.

 ■ Communication error history (on page 10-20).

The following describes the operation flow if a communication error occurs:

- If a communication error occurs when reading data from the trigger device, processing of the group is not started.
- If a communication error occurs when reading data from the conditional bit for the enabled-disabled setting, the setting is considered to be "disabled," and processing of the group is not executed.
- If a communication error occurs when turning ON (or OFF) a notification device, there is no notification to the connected module.

Chapter 6 LOGGING FUNCTION

6 - 1 Continuous Trend

This function reads out numeric data from connected modules periodically and records it to the internal memory of the CMC15G. The continuous trend function can be used to monitor, at constant intervals, changes in values.

■ Description of operation

● Startup

Data read-out from connected modules is executed at specified intervals.

● Process

The following describes how information from connected modules is saved to the internal memory:

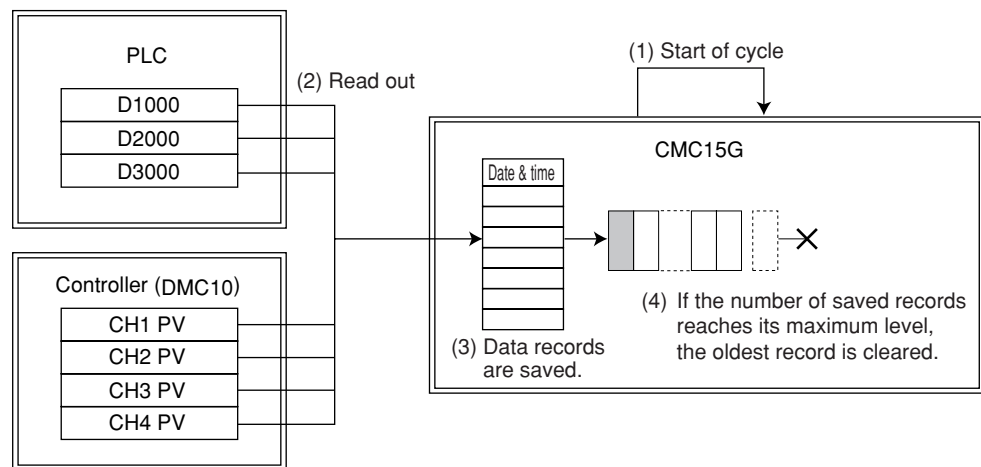

- (1) For startup of the continuous logging function, the time is monitored at intervals specified inside the CMC15G.
- (2) Numeric data is read out from the source.
- (3) The data, which is read out from the internal memory of the CMC15G, is saved as a record with date and time recorded.
- (4) If the number of saved records exceeds the maximum, the latest record is written over the oldest record.

! Handling Precautions

- The maximum number of records, which can be saved for one group can be specified. However, the settings may need to be adjusted on account of other groups or the entire log function, so that the usage capacity of the internal memory does not exceed the maximum level.

■ Operation if an error occurs

- Cycle overrun

If the collection cycle is too short for the amount of data to be collected, a cycle overrun occurs. If this occurs, treatment of the record is as described below. A separating vertical line is displayed on the LogViewer.

Actual time	No.1	No.2	No.3
10:10:10	1 0 0	2 0 0	3 0 0
10:10:11	1 0 1	2 0 1	3 0 1
10:10:12	1 0 2	---	---
10:10:13	---	2 0 3	3 0 3
10:10:14	1 0 4	2 0 4	3 0 4
10:10:15	1 0 5	2 0 5	3 0 5
10:10:16	1 0 6	2 0 6	3 0 6

←Data delay in Nos. 2 and 3

←Data received successfully in Nos. 2 and 3 at 13 s.

Contents of record

Recorded time	No.1	No.2	No.3
10:10:10	1 0 0	2 0 0	3 0 0
10:10:11	1 0 1	2 0 1	3 0 1
10:10:12	1 0 2	2 0 3	3 0 3
10:10:14	1 0 4	2 0 4	3 0 4
10:10:15	1 0 5	2 0 5	3 0 5
10:10:16	1 0 6	2 0 6	3 0 6

Data received successfully is recorded in 12 s row.

There is no record at 13 s.

- Collection device read-out communication error

If a communication error occurs while reading data due to a module fault, one invalid record showing that data has not been collected is recorded. (This record is displayed as "---" on the LogViewer.)

When there is successfully read data in the same group in which a communication error occurred, information showing the valid data is recorded in the invalid record. (The total amount collected is displayed on the LogViewer.)

- Discontinuous data

If any of the following conditions arises, the record is not recorded during this period. (A separating vertical line is displayed on the LogViewer.)

- The CMC15G is turned OFF.
- Read-out is stopped by a change in the enabled-disabled setting.
- The time is advanced by the date and time adjustment function or the online date and time setting function.

● Display

The REC LED indicator functions as described below during continuous trend logging.

Status	Meaning
Off	Not recording
Lit green	A trend function is recording

6 - 2 Captured Trends Function

The captured trends function reads numeric data from connected modules periodically. When a trigger occurs, it saves data from before and after the trigger to the internal memory of the CMC15G.

Waveform information from before and after the occurrence of an alarm is kept and can be used for analysis during maintenance work.

■ Description of operation

● Startup

Data is read from connected modules at specified intervals.

If a trigger is detected, the data written to the ring buffer before and after the occurrence is read from the buffer and saved.

There are two methods of starting the captured trends function, as described below.

- Trigger capture (OFF→ON): Executed when the value of a specified bit changes from OFF to ON.
- Trigger capture (ON→OFF): Executed when the value of a specified bit changes from ON to OFF.

● Process

The following describes the process of periodic data collection and saving of data before and after an alarm occurs:

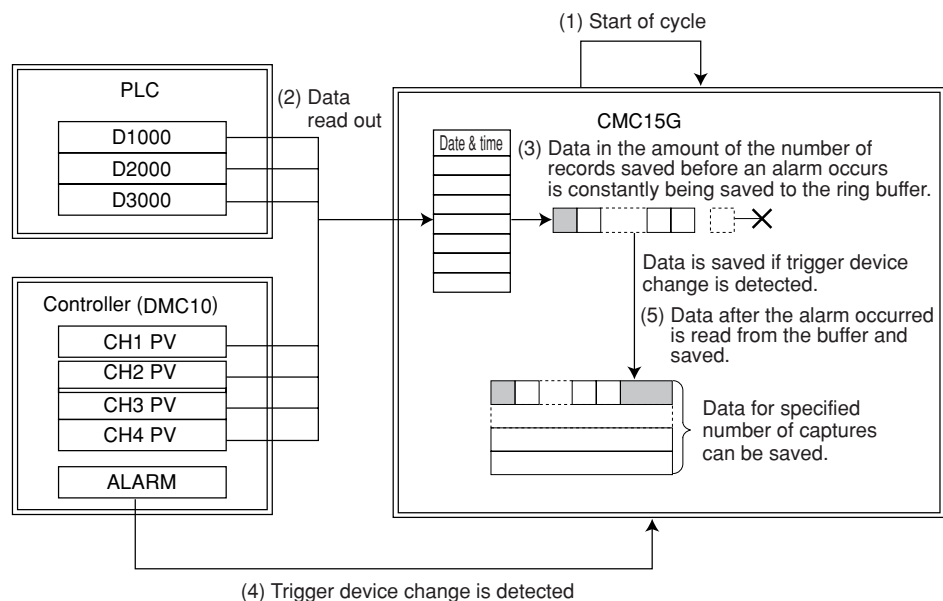

- (1) The captured trends function is started up at intervals specified inside the CMC15G.
- (2) Data is read from the source.
- (3) Data which has been read is written to the ring buffer with the date and time.
- (4) If the specified bit is changed to ON (or OFF), the data before the alarm occurred is read from the ring buffer and saved.
- (5) Data after alarm occurrence is read from the ring buffer and saved.

📖 Note

- The user can select whether or not past captured data should be overwritten if the memory for captured data is full.

Handling Precautions

- If a trigger occurs when the enabled-disabled setting is "disabled," it is ignored.
- If a new trigger occurs when saving data after a trigger has occurred, the new trigger is ignored.
- In addition to the memory area for captures, there is a separate memory for the ring buffer.
- After the maximum number of captures have been saved, if the overwrite save function is not set, the captured trends function will not operate until recorded data is cleared.
- The settings for the number of captures and the number of saved records should take other groups and the overall logging function into account, so that the capacity of the internal memory is not exceeded.

Note

- If the data type of the trigger device is a word, changes in value are judged according to the contents of bit 0 (the least significant bit).

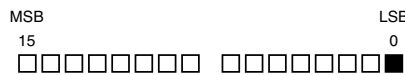

Additionally, the bit that is initialized by trigger device initialization is bit 0 (the LSB) only.

● Display

The REC indicator functions as described below while the captured trends function is active.

Status	Meaning
Off	Not recording
Lit green	Trend recording is in progress.
Flashing green (1 s intervals)	The captured trends function is running after a trigger occurred.
Flashing green. (200 ms intervals)	Captured trends function is running but capture memory is full.

Note

- The REC LED indicator starts flashing in green (at 1 s intervals) when the trigger of the captured trends function is activated. Note that this is not the time at which the post-trigger data is saved.
- The REC LED indicator starts flashing green (at 200 ms intervals) when the last trigger of the number of captures for the captured trends function is activated. Note that this is not the time at which the post-trigger data is saved completely.

● Operation if an error occurs

- Trigger device read-out communication error

If a communication error occurs when reading data from the trigger device, the trigger is not activated.

- Cycle overrun

If the collection cycle is too short for the amount of data to be collected, a cycle overrun occurs. If this occurs, treatment of the record is as described below. A separating vertical line is displayed on the LogViewer.

Actual time	No.1	No.2	No.3
10:10:10	1 0 0	2 0 0	3 0 0
10:10:11	1 0 1	2 0 1	3 0 1
10:10:12	1 0 2	---	---
10:10:13	---	2 0 3	3 0 3
10:10:14	1 0 4	2 0 4	3 0 4
10:10:15	1 0 5	2 0 5	3 0 5
10:10:16	1 0 6	2 0 6	3 0 6

←Data delay in Nos. 2 and 3

←Data received successfully in Nos. 2 and 3 at 13 s.

Contents of record

Recorded time	No.1	No.2	No.3
10:10:10	1 0 0	2 0 0	3 0 0
10:10:11	1 0 1	2 0 1	3 0 1
10:10:12	1 0 2	2 0 3	3 0 3
10:10:14	1 0 4	2 0 4	3 0 4
10:10:15	1 0 5	2 0 5	3 0 5
10:10:16	1 0 6	2 0 6	3 0 6

Data received successfully is recorded in 12 s row.

There is no record at 13 s.

- Collection device read-out communication error

If a communication error occurs while reading data due to a module fault, one invalid record showing that data has not been collected is recorded. (This record is displayed as "---" on the LogViewer.)

When there is successfully read data in the same group in which a communication error occurred, information showing the valid data is recorded in the invalid record. (The total amount collected is displayed on the LogViewer.)

- Discontinuous data

If any of the following conditions arises, the record is not recorded during this period. (A separating vertical line is displayed on the LogViewer.)

- The CMC15G is turned OFF.
- Read-out is stopped by a change in the enabled-disabled setting.
- The time is advanced by the date and time adjustment function or the online date and time setting function.

6 - 3 Data Log

The data log function records information from the connected modules in the internal memory of the CMC15G when a change in the bit is detected. Status data from the connected modules for one cycle is saved if a system batch process is started or if an error occurs in the connected modules.

■ Description of operation

● Startup

If a change in the bit of a specified connected module is detected, the data read-out from the connected module is executed.

There are two kinds of trigger startup methods, trigger (OFF→ON) and trigger (ON→OFF), as described below.

Trigger (OFF→ON): Executed when the value of a specified trigger device is changed from OFF to ON.

Trigger (ON→OFF): Executed when the value of a specified trigger device is changed from ON to OFF.

● Process

The following describes how the settings for the connected modules are saved if a process (trigger occurrence) for the system arises:

(1) The CMC15G monitors the bit periodically. If the bit is turned ON, the data log function is started.

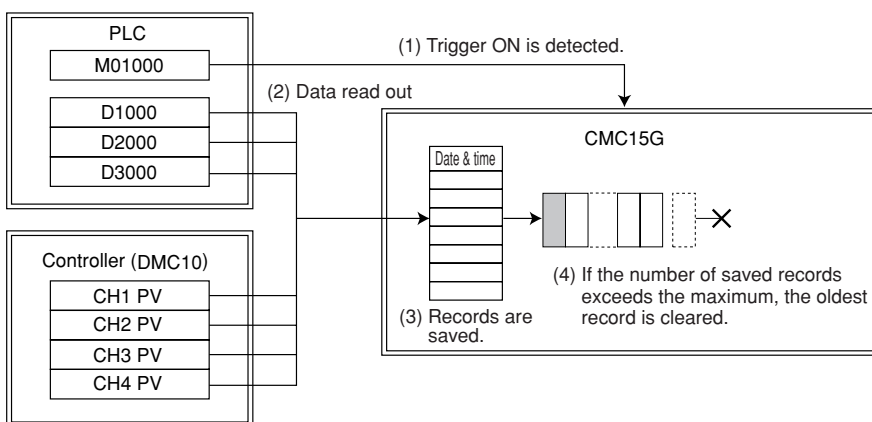

(2) Numeric value data is read from the specified device.

(3) The data which was read is saved to the internal memory of the CMC15G as records with date and time data.

(4) If the number of saved records exceeds the maximum, the next record is overwritten onto the oldest record.

📖 Note

- If the data type of the trigger device is a word, changes in value are judged according to the contents of bit 0 (the least significant bit).



Additionally, the bit that is initialized by trigger device initialization is bit 0 (the LSB) only.

Handling Precautions

- The maximum number of records that can be saved for one group can be specified in the configuration process. However, the settings should take other groups and the overall logging function into account, so that the capacity of the internal memory is not exceeded.

● Operation if an error occurs

- Trigger device read-out communication error
If a communication error occurs when reading data from the trigger device, the trigger is not activated.
- Collection device read-out communication error
If a communication error occurs while reading data due to a module fault, one invalid record showing that data has not been collected is recorded. (This record is displayed as "---" on the LogViewer.)
When there is successfully read data in the same group in which a communication error occurred, information showing the valid data is recorded in the invalid record. (The total amount collected is displayed on the LogViewer.)

6 - 4 Event Log

■ Description of operation

● Startup

There are two startup methods, cyclic (auto) and cyclic (fixed).

- Cyclic (auto): The execution interval is automatically determined from the average process time.
- Cyclic (fixed): The event log is executed at specified intervals.

● Process

Multiple bits registered for the process are monitored periodically.

When the state (ON/OFF) of a specified bit changes, the device's type and the time are recorded. There are three kinds of bit ON/OFF detection (events) as described below.

- Trigger (OFF→ON): Executed when the value of a specified trigger device is changed from OFF to ON.
- Trigger (ON→OFF): Executed when the value of a specified trigger device is changed from ON to OFF.
- Trigger (OFF→ON/ON→OFF): A record is added to the event log at both the start and finish of the trigger.

When multiple bits are monitored and a change occurs, the following describes how the event and the date and time are saved:

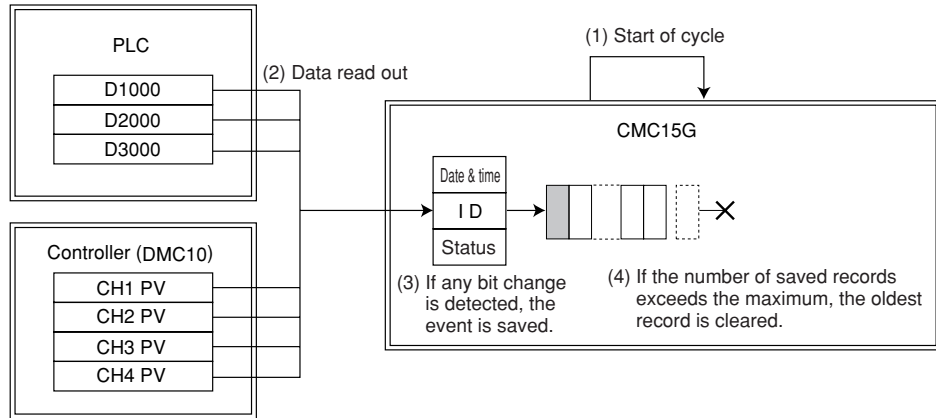

! Handling Precautions

- The maximum number of records that can be saved for one group can be specified in the configuration process. However, the settings should take other groups and the overall logging function into account, so that the capacity of the internal memory is not exceeded.

📖 Note

- If the data type of the trigger device is a word, changes in value are judged according to the contents of bit 0 (the least significant bit).



Additionally, the bit that is initialized by trigger device initialization is bit 0 (the LSB) only.

● **Operation if an error occurs**

- **Cycle overrun**
If the process is not completed within the specified cycle, the process is not run again.
- **Bit read-out communication error**
If a communication error occurs in the bit read-out process, the bit's value is not judged and no judgement results are recorded.

6 - 5 Groups and Execution Conditions

The following describes the number of groups, which can be registered for each logging function, and the startup conditions:

■ Groups

Function	Max. groups	Max. records per group
Continuous trend, captured trends	20	30
Data log	20	100
Event log	20	100

■ Execution conditions

Function	Startup condition		Enabled-disabled setting	Sequential execution	Notification process
	Cycle	Trigger			
Continuous trend	○	×	○	×	×
Capture trends	×	○	○	×	×
Data log	×	○	○	×	×
Event log	○	×	○	×	×

○: Available ×: Not available

For details about startup conditions and the enabled-disabled setting, refer to  Section 5-5, Execution Conditions and Processing for Each Function.

Chapter 7 EXTENDED FUNCTIONS AND OTHER FUNCTIONS

7 - 1 Status Notification

This function sends a notification to the host station regarding the status of the CMC15G.

■ Running notification

This function is used when the host station needs to confirm that the CMC15G is operating correctly. By monitoring a notification device specified by the CMC15G, the host station can confirm that the CMC15G is operating correctly. The running notification function turns ON a notification device specified by the host station at specified intervals (in "min" (minute)) while the CMC15G is running.

● Process

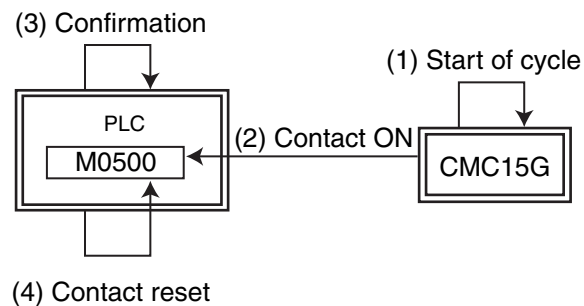

- (1) The CMC15G starts up at set intervals.
- (2) The specified notification device is turned ON.
- (3) The PLC monitors the notification device at intervals twice longer than those set for the CMC15G.
- (4) When the notification device specified by the PLC is found to be ON, the bit is turned OFF.

● Operation if an error occurs

- If a process is not completed within the specified cycle, special contact SM901.0 (cycle overrun) inside the CMC15G turns ON.
☞ Chapter 12, CONTACTS AND REGISTERS INSIDE THE CMC15G
- If a communication error occurs when the notification device is turned ON (or OFF), no notification is sent to the connected module.

■ Battery alarm notification

This function notifies the host station regarding the battery status of the CMC15G.

Battery alarm: Voltage level of the CMC15G's backup battery is below a specified level.

By monitoring the specified notification device, the status of the CMC15G can be checked. When alarm status occurs, the bit is turned ON at the intervals specified by the user (in "min" (minute)).

● Process

The following describes how periodic notification of the battery alarm is sent to the host station.

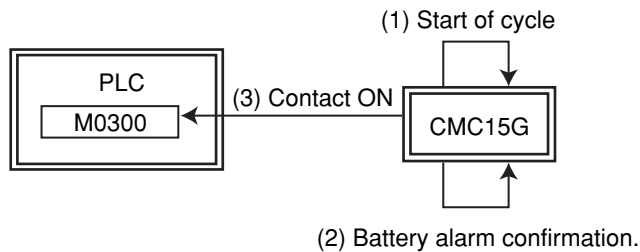

(1) The battery alarm notification function is started up at set intervals.

(2) Battery alarm occurrence is checked.

(3) If there is a battery alarm, the specified bit on the host station is turned ON.

● Operation if an error occurs

- If a process is not completed within the specified cycle, special contact SM901.0 (cycle overrun) inside the CMC15G turns ON.

☞ Chapter 12, CONTACTS AND REGISTERS INSIDE THE CMC15G

- If a communication error occurs when the notification device is turned ON (or OFF), no notification is sent to the connected module.

■ Capture notification/Capture limit notification

Only the CMC15GD01 advanced model can use these functions.

Capture notification: At least one data record has been collected by the captured trends function.

Capture limit notification: The captured trends function cannot accept another trigger.

! Handling Precautions

The capture and capture limit statuses are retained until the data is downloaded or the recorded data is cleared.

By monitoring the specified notification device, the status of the CMC15G can be checked. When alarm status occurs, the bit is turned ON at the intervals specified by the user (in "min" (minute)).

● Startup

The capture notification and capture limit notification function are started up at specified intervals (in "min" (minute)).

● Process

A specified bit is turned ON at the intervals specified (in "min" (minute)) when the relevant status occurs. The following describes the process for sending periodic capture limit notification to the host station.

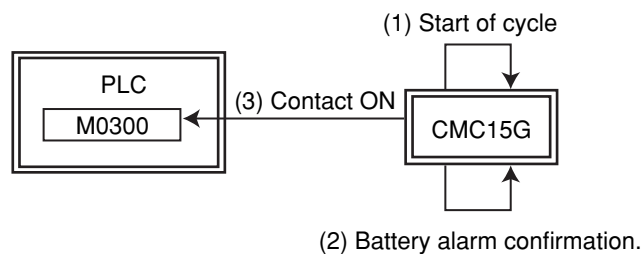

(1) The time is monitored at specified intervals for startup of the capture notification and capture limit notification functions.

(2) The capture status is checked.

(3) If the memory for capture is full, the specified bit on the host station is turned ON.

● Operation if an error occurs

- If a process is not completed within the specified cycle, special contact SM901.0 (cycle overrun) inside the CMC15G turns ON.

➔ Chapter 12, CONTACTS AND REGISTERS INSIDE THE CMC15G

Additionally, note that the process is not started again.

- If a communication error occurs when the notification device is turned ON (or OFF), no notification is sent to the connected module.

7 - 2 Communication Error Notification

The communication error notification function sends notice of an error to the host station if an error occurs in communication between the CMC15G and a connected module. By monitoring a specified bit, the host station can check if there has been an error in communication with a connected module.

A communication error occurs if the retry-out or error response occurs during communication. If a communication error is detected, a bit corresponding to the module in which the error occurred is turned ON.

Notification of a communication error is sent to the host station in the following way:

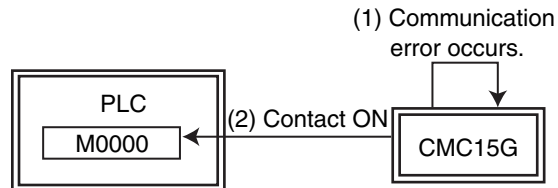

- (1) The CMC15G detects the error.
- (2) The specified bit on the host station is turned ON.

● Operation if an error occurs

If a communication error occurs when the notification device is turned ON (or OFF), connected modules are not notified.

! Handling Precautions

- Even after resumption of normal operation, the specified bit on the host station is not turned OFF.
- Notification occurs only once, even if normal operation is not restored after an error such as faulty wiring.
- If normal operation and error status restoration occur repeatedly, the shortest interval at which the specified bit on the host station is turned ON is 1 s.

7 - 3 Date and Time Adjustment

This date and time adjustment function adjusts the year, month, day, hour, minute, and second data on the CMC15G to the date and time of the system. The settable date and time range is from 00:00:00 on January 1, 2000 to 23:59:59 on December 31, 2099. You need to separately specify a memory address on a connected module for each of year, month, day, hour, minute, and second.

If a host station such as a PLC controls the date and time for the overall system, the date and time of the CMC15G can be adjusted to the date and time of the host station at a time specified by the host station (for example, the bit used as the trigger device can be turned ON once a day).

When a change in the specified bit on the host station is detected, the clock data is read out from the host station and this data is set for the CMC15G.

There are two kinds of trigger startup methods, trigger (OFF→ON) and trigger (ON→OFF), as described below.

- Trigger (OFF→ON): Executed when the value of a specified bit is changed from OFF to ON.
- Trigger (ON→OFF): Executed when the value of a specified bit is changed from ON to OFF.

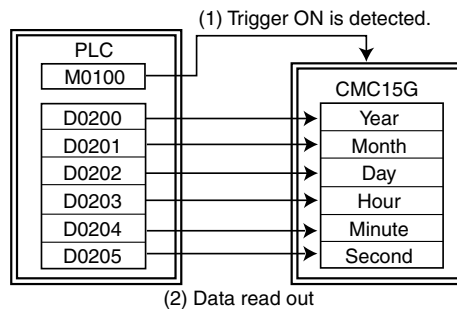

- (1) The CMC15G monitors the bit periodically. If the bit changes to "ON," the date and time adjustment function is activated.
- (2) The year, month, day, hour, minute, and second are read from the specified addresses, and the CMC15G's time data is set accordingly.

! Handling Precautions

- Date and time adjustment cannot operate while another trigger is being processed. If the trigger for the date and time adjustment is detected while another trigger is being processed, reading of the date and time data may be delayed.
- The CMC15G does not reset the trigger device. The trigger device is turned off by the host station when a certain period of time has elapsed after the bit was turned on.

📖 Note

- After date and time have been adjusted, record of the change of the CMC15G internal clock remains in the system history. The system history can be checked with the history display function of GatewayEditor.
- If the data type of the trigger device is a word, changes in value are judged according to the contents of bit 0 (the least significant bit).



Additionally, the bit that is initialized by trigger device initialization is bit 0 (the LSB) only.

● Operation if an error occurs

- If a communication error occurs when reading the trigger device, the date and time data is not adjusted.

7 - 4 Option Configuration

This option configuration function sets up optional functions of the CMC15G main unit. Optional functions like CMC15G startup or initialization of variables (bits) related to functions can be set.

■ Node address

The node address for the CMC15G can be changed. A node address is specified when the CMC15G is configured as a slave station. It is used for communication with the host computer.

■ Startup delay

This function delays the operation of the CMC15G after power-up until the set time.

The delay time can be set in seconds (s). If the startup of a connected module is later than that of the CMC15G, a communication error may occur.

By setting the startup delay, operation of the CMC15G can be postponed until all connected modules have been started. The setting range is 1 to 360 s.

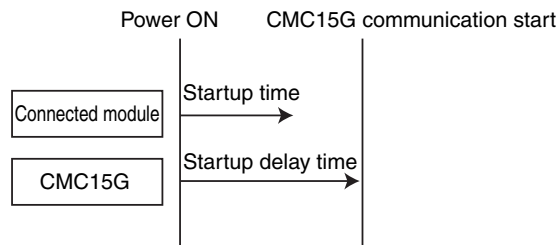

! Handling Precautions

- Even when the startup delay has been set, the RUN indicator will light up immediately after the power has been turned ON.

■ Trigger device initialization

In trigger processing, normally the host station initializes the trigger device. However, if this is not desired, the CMC15G, when it starts up, can initialize trigger devices that have been changed to execution status.

Functions that can be initialized are the basic data transmission and module setup functions. You can select "Initialize" or "Do not initialize" for each function. The initial value is "Initialize":

For trigger (ON→OFF), the bit is turned ON.

For trigger (OFF→ON), the bit is turned OFF.

A trigger device initialization function for date and time adjustment has been added in F/W versions 0002.01.01 and later.

If a version earlier than Ver. 0002.01.01 is used, or if GatewayEditor Ver. 1.x.x is used, the trigger device initialization function is disabled.

- If a project that was created using a previous version of GatewayEditor is opened with GatewayEditor Ver. 2.x.x or later, the trigger device initialization function for date and time adjustment is disabled.
- If a project that was created using the new GatewayEditor is used with previous firmware, downloading begins in the same way as when the trigger device function for date and time adjustment is set to disabled.

If the trigger device function for date and time adjustment is enabled, a message appears at the time of downloading. If this happens, downloading will begin after the setting has been changed to disable the function.

! Handling Precautions

- Trigger device initialization should not be enabled when the same trigger device is used for multiple groups. If it is, groups may not detect the ON trigger device, depending on the trigger device initialization timing.
- Initialization of the trigger device must not be enabled when special contact (SM900.0 to SM999.F) is used as a trigger device. If it is, initialization of the trigger device will be judged to have failed and the process will not be executed, since the data writing process will be prohibited. Even if the internal event EM has not failed, initialization is not actually done.
- The trigger device cannot be initialized if the group's enabled-disabled setting results in a disabled state.

The following describes how to transmit data with a trigger (OFF→ON) and how to initialize the trigger device.

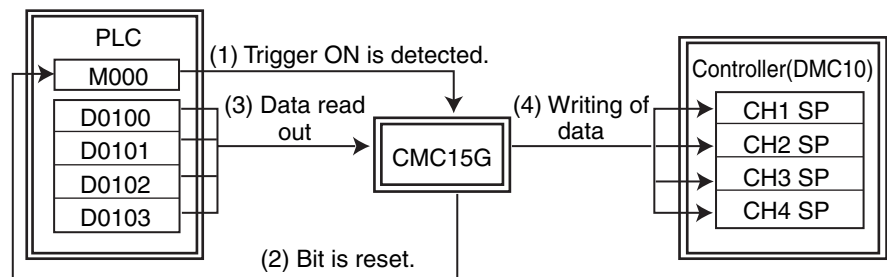

- (1) The CMC15G monitors the trigger device periodically. After the trigger device is turned ON, the trigger is executed.
- (2) The trigger device is initialized (in this case, the bit is turned off).
- (3) Data is read from the source.
- (4) The data is written to the destination.

📖 Note

To emulate the operation of the CMC10G, set to "Initialize."

■ Initialization of completion notification device and error notification device

This function initializes the completion notification device or error notification device specified by the CMC15G when a process of some function starts up. Normally, the host station initializes the notification device. However, if this is not desired, the CMC15G can initialize it.

The functions that you can initialize are the basic functions of data transmission and module setup. For each, either "Initialize" or "Do not initialize" can be selected. The default value is "Initialize."

Since the completion notification device or error notification device is reset after the process has been started up, completion or error notification of the currently running process can be detected.

The following describes how to transmit data with a trigger (OFF→ON) and how to initialize the trigger device.

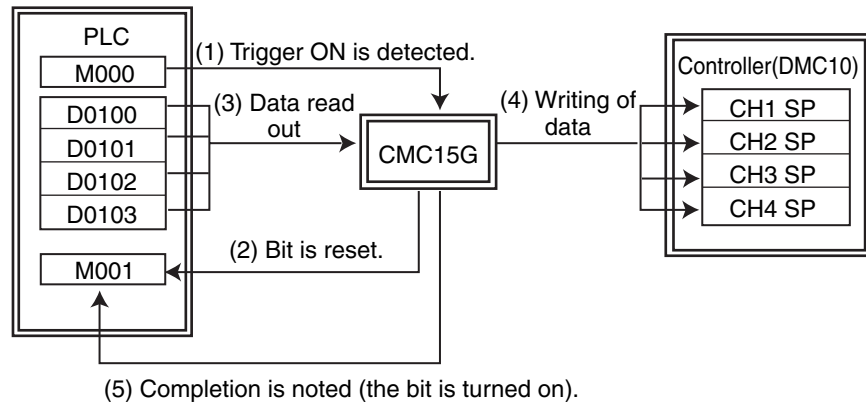

- (1) The CMC15G monitors the trigger device periodically. After the trigger device is turned ON, the trigger is executed.
- (2) The completion notification device is reset.
- (3) Data is read from the source.
- (4) The data is written to the destination.
- (5) After all write processes have been completed, the completion notification device is turned on.

7 - 5 Digital Signal Input/Output Bus

A digital signal can be input or output to/from the DMC10 by utilizing the DMC10's event bus output and external switch bus input. In this way tasks can be accomplished such as monitoring DMC10 alarms using the event bus output or change-over of RUN/READY or other operations with the external switch bus input. There are four digital signal input/outputs.

When utilizing the event bus output of the DMC10 as digital signal input of the CMC15G in a function setup, "BM0000*" (where "*" stands for a numeral from 0 to 3) is input to a memory address location.

When the digital signal output of the CMC15G is used as external switch bus input of the DMC10, "BM0000*" (where "*" stands for a numeral from 0 to 3) is input to a memory address location.

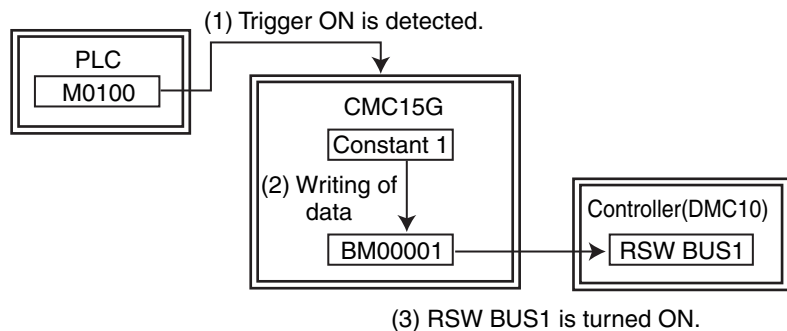

In the above figure, the operation flow is as follows. (This example shows an operation that utilizes data transmission.)

- (1) The CMC15G monitors the trigger device periodically. After the trigger device is turned ON, the trigger is executed.
- (2) Constant value "1" is written as part of "BM00001."
- (3) The RSW BUS1 is turned ON.

! Handling Precautions

- The input process delay and output delay of the digital signal may vary depending on the internal processing load.
- When the event bus output from the DMC10 is used for the digital signal input of the CMC15G, the processing load is checked on the online monitor and appropriate measures are taken so that the digital signal input does not change for a period of time twice longer than the processing cycle of the CMC15G.
- The delay time of the digital signal output from the CMC15G may vary depending on the processing load. Allow sufficient time when checking the process on the online monitor.

7 - 6 Loader Through-Communication

When ThroughComm is used as a tool for changing the CMC15G to THROUGH mode, the dedicated loader for any Yamatake controller can be operated through the CMC15G. The dedicated loaders which can be connected include:

- SLP-C45
- SLP-C35
- SLP-D10
- MLP100, etc.

! Handling Precautions

- Before executing loader through-communication, the CMC15G is changed to through-communication mode (THROUGH mode). In through-communication mode, all communications handled by the CMC15G are stopped and only the loader through-communication is executed.

Since loader through-communication may adversely affect the operation of the user system, you must use it carefully, taking into consideration the effects on the overall system.

- Each dedicated loader is connected using the communication configuration that has been set for it in the module constitution. Before starting the loader through-communication, it is necessary to correctly configure communication parameters such as transmission speed in the CMC15G module constitution.

■ Setup of loader through-communication

As an example, the following shows how to connect to the SDC45 at node address 2 using the SLP-C45:

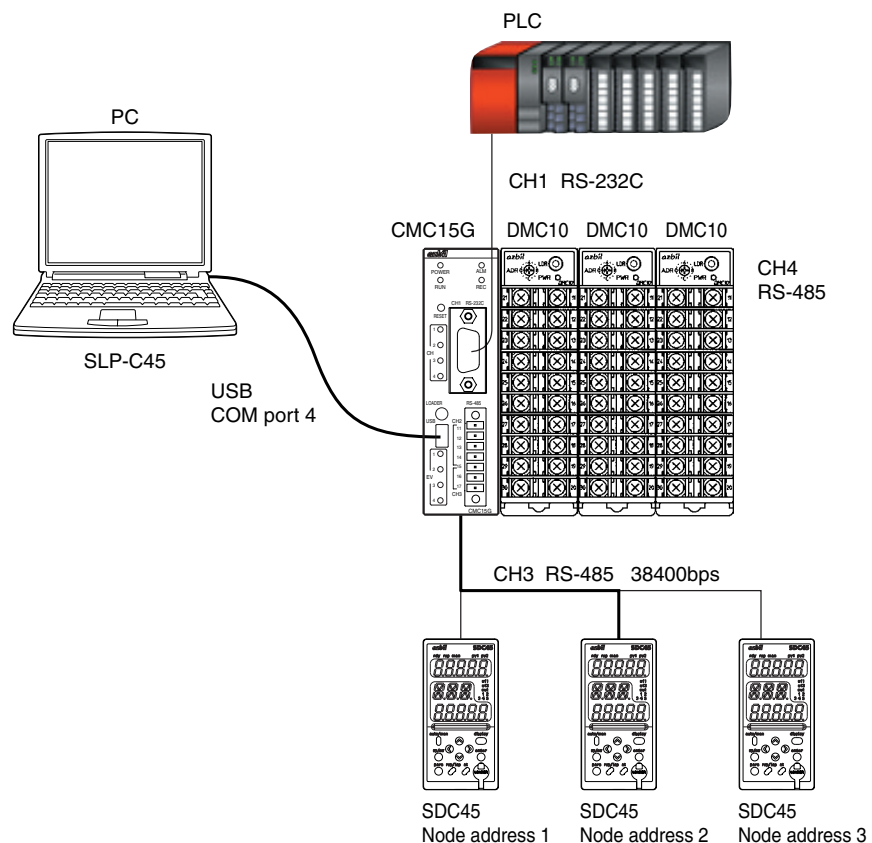

Example of module constitution

Procedures

- (1) Select [ThroughComm] to run it.

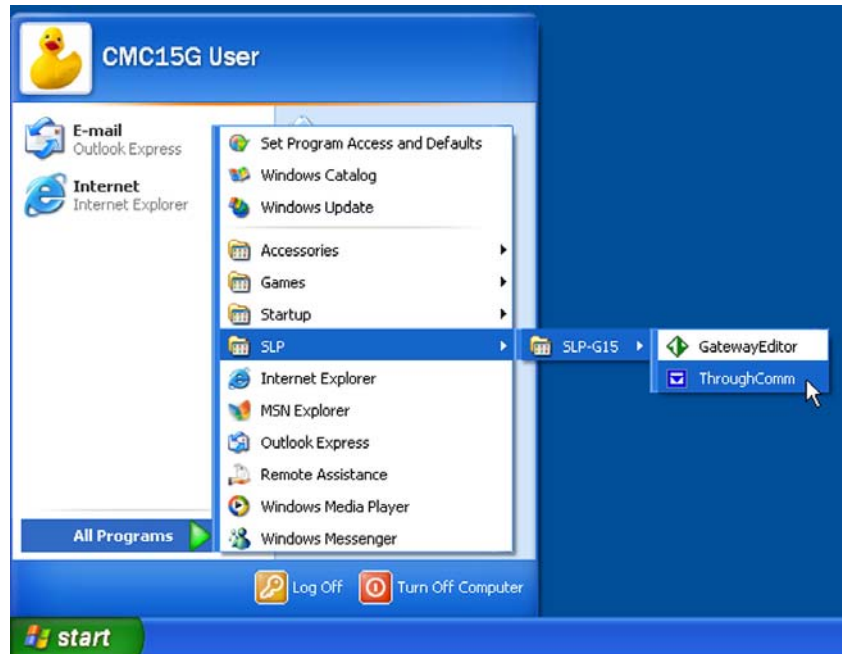

>> The following window will appear:

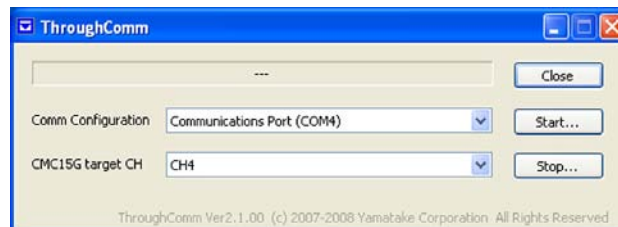

- (2) Select the communication port (COM port) No. of the personal computer connected to the CMC15G in the [Comm Configuration] box. In this example, "COM port 4" is set.
- (3) Select the communication channel number to which the module is connected in the [CMC15G target CH] box. In this example, "CH4" is set.
- (4) Click the [Start] button.

>> The confirmation window saying "CMC15G starts the THROUGH communication. Continue?" will appear.

- (5) Click the [OK] button.



>> The CMC15G changes to through-communication mode.

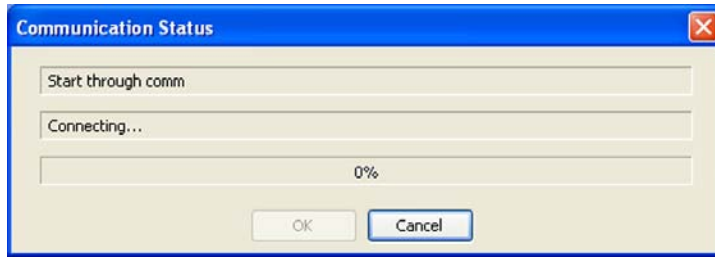

- (6) The high-speed flashing of the RUN indicator on the front panel indicates that the mode has been changed successfully.
- (7) Start up the dedicated loader for each connected module. In this example, the SLP-C45 is started.
- (8) After starting the SLP-C45, select [Option] from [Menu].

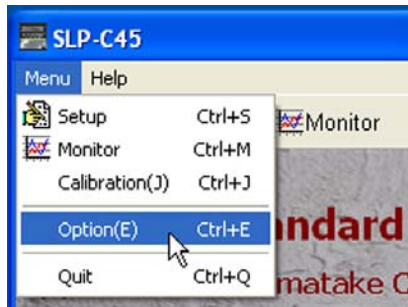

>> The following window will appear:

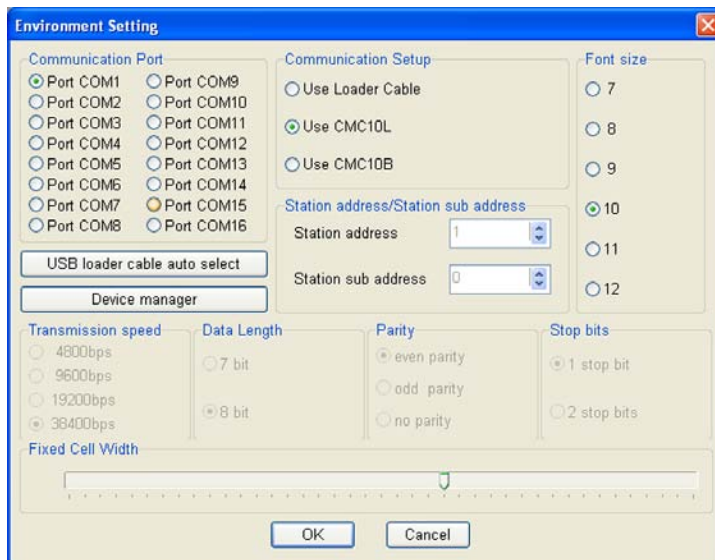

-
- (9) Select the communication port (COM port) of the personal computer connected to the CMC15G in the "Communication Port" area.
In this example, COM port 1 is selected.
 - (10) Check on [Use CMC10L] in the "Communication Setup" area.
 - (11) Set the station address in the "Station address/Station sub address" area.
This is the station address of the controller you wish to connect to, in this example "2."
 - (12) Set the transmission speed, data length, parity, and stop bits suitable for the controller that will be connected.
In this example, the transmission speed is 38400 bps.
Set the data length, parity, and stop bits to the same settings as those of CH3 of the CMC15G.

After the above steps have been completed, the SLP-C45 can be connected to the controller.

■ Quitting loader through-communication

- (1) Finish the work requiring the special loader, and complete online operations such as numeric value monitoring or trend monitoring.
- (2) Click the [Stop] button in the ThroughComm window.
If the ThroughComm window is not started up, start it up from the [Start] menu.
>> The following window will appear:

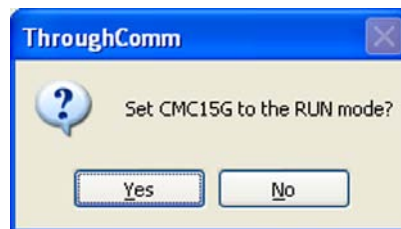

- (3) To start it up, click [Yes]; otherwise click [No].
- (4) Check the RUN indicator on the front panel to verify that the mode has been changed.
 - RUN mode: Green light.
 - STOP mode: Off.
- (5) Click the [Close] button to exit ThroughComm.

! Handling Precautions

- Before changing to RUN mode, make sure that system operation will not cause problems. Sudden start of operation may greatly affect the overall system.
- The mode display in the upper portion of the ThroughComm window shows the result of the most recent mode change.

If you have quit ThroughComm once, the mode of the ThroughComm may not match the mode of the CMC15G main unit. Check the mode status of the CMC15G with the RUN indicator on the front panel.

- If you quit ThroughComm in the loader through-communication execution status, all communications handled by the CMC15G will remain off. Follow the steps below to resume operation.
 - Click the [Stop] button in the ThroughComm window to change the mode to RUN mode.
 - Keep the RESET switch on the CMC15G pressed for at least 5 s.
 - Turn OFF the power, and then turn it ON again.
- While the CMC15G is running in through-communication mode, do not connect to it using GatewayEditor.

Chapter 8 GATEWAYEDITOR

8 - 1 Overview of GatewayEditor

■ Functions

GatewayEditor provides the major functions described below.

- Configuration of functions (data transmission, module setup, internal events, etc.)
- Downloading and uploading of settings
- Functional check of CMC15G main unit (online monitoring and online operation)

■ System requirements

O.S.	Windows *1
Language *2	Japanese, English
CPU	Pentium compatible CPU, 400 MHz or faster
Memory	Free RAM capacity, 256 MB or more
Hard disk drive	Free capacity, 128 MB or more
Display	Resolution of Super VGA (800 × 600) or more
CD-ROM drive	Required only when installing GatewayEditor.
Keyboard	Required.
Mouse	Required.
USB port *3	Required when connecting to the main unit with the USB cable.cable.
COM port *3	Required when connecting to the main unit with the loader cable.cable.

*1. Windows Me, Windows 98, Windows 95, Windows XP 64-bit Edition, Windows Vista 64-bit Edition and Windows Server (Windows 2000 Server, Windows Server 2003, Windows Home Server, Windows Server 2008, etc.) are not supported.

*2. If GatewayEditor is started up in a language environment other than Japanese, the menus are displayed in English.

*3. To communicate with the CMC15G, the personal computer must have either a USB port or COM port interface.

8 - 2 Installing GatewayEditor

■ Installing the SLP-G15

! Handling Precautions

- Do not connect the CMC15G and personal computer with the USB cable during installation. If they are connected, the USB drivers will not be installed correctly.

- (1) Insert GatewayEditor Setup CD-ROM into the CD-ROM drive. Double-click [My Computer] to open it.



- (2) Move the mouse cursor onto the icon for the CD-ROM drive, press the right mouse button, and select [Open] from the pop-up menu.

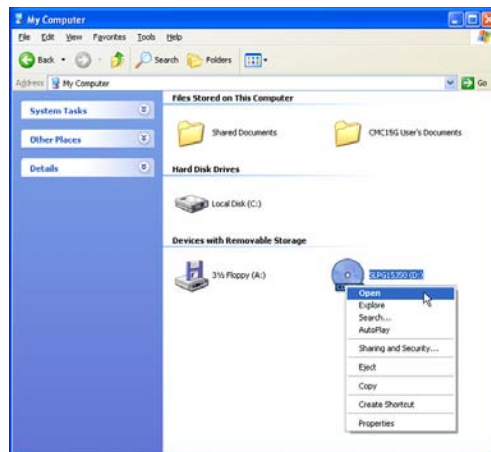

>> The contents of the CD-ROM are shown.

- (3) Double-click Setup.exe.

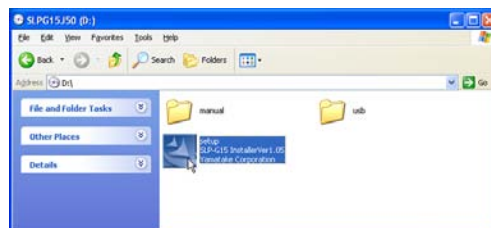

>> The setup wizard screen will appear. The License Agreement screen will appear during installation. Check the contents of the license agreement. If you agree with the contents of the license agreement, click the [Yes] button. If you do not agree, click the [No] button and installation will be cancelled.



>>Subsequently, a screen prompting you to input a serial number will appear.



(4) Input a user name, company name, and serial number. The serial number is printed on the label attached to the CD-ROM case. If the serial number is not input accurately, the installation process will not continue.

(5) If you checked [Custom] in the “Setup Type” area,



check [GatewayEditor] and [USB Driver] on the Select Features screen.

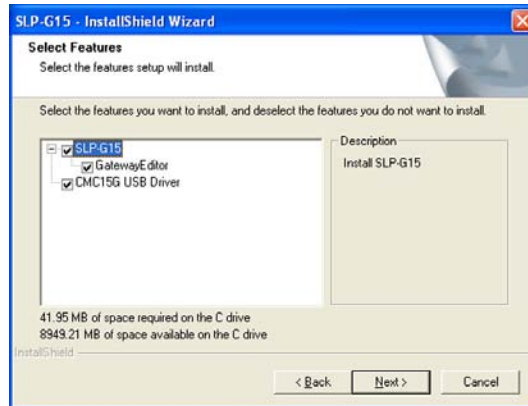

Components which you do not install now can be installed later by choosing the [Modify] option in the installation wizard .

(6) If the USB drivers are installed, the following two screens may appear:



If this happens, click the [Continue Anyway] button.

(7) Follow the instructions that appear on the screen to continue the setup.

Handling Precautions

Warning messages during driver installation. This warning message will appear if the drivers do not pass Microsoft's WHQL (Windows Hardware Quality Labs) test for conformity to Windows standards. However, Yamatake has conducted a complete functional check of these drivers. Therefore, continue the installation, since no problems will occur in the system if these drivers are installed.

Note

After GatewayEditor installation, files with the extension .gwp are registered as GatewayEditor project files. If you double-click a gwp file, GatewayEditor will start up and open the file as a project file.

■ Uninstalling the SLP-G15

(1) From the [Start] menu, select [Control Panel].



>> The Control Panel window will appear.

(2) In Windows 2000, Windows XP, and Windows Vista, double-click [Add/Remove Programs], [Add or Remove Programs], and [Programs and Features], respectively.

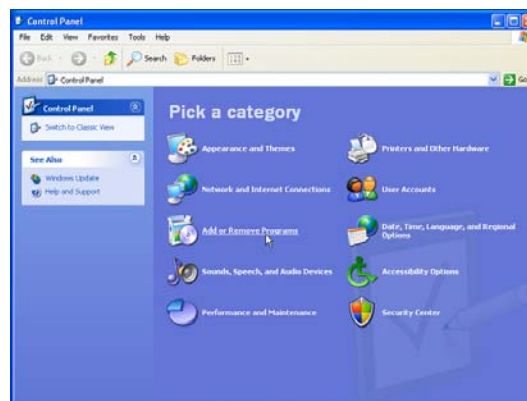

>> A list of installed programs is displayed.

(3) Select [SLP-G15]. In Windows 2000, Windows XP, and Windows Vista, double-click [Change/Remove], [Change/Remove], and [Uninstall/Change], respectively.

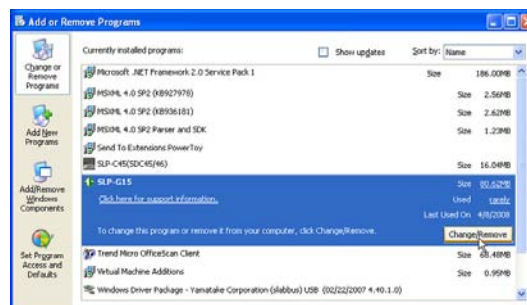

>> GatewayEditor and USB driver are then removed.

 **Note**

Project files created by the user, address selection palette favorites, etc. are not removed.

■ **Upgrade-installing and maintenance-installing the SLP-G15**

If the SLP-G15 setup.exe file is run after the SLP-G15 has already been installed on the personal computer, instead of a general new installation, one of the following two processes is started:

● **Upgrade installation**

If the setup.exe program is a newer version of the SLP-G15, the currently installed version will be removed, and the new version will be installed.

No data is overwritten onto project files created by the user, address selection palette favorites, etc.

● **Maintenance installation**

If the setup.exe program is the same version of the SLP-G15, it operates in maintenance installation mode.

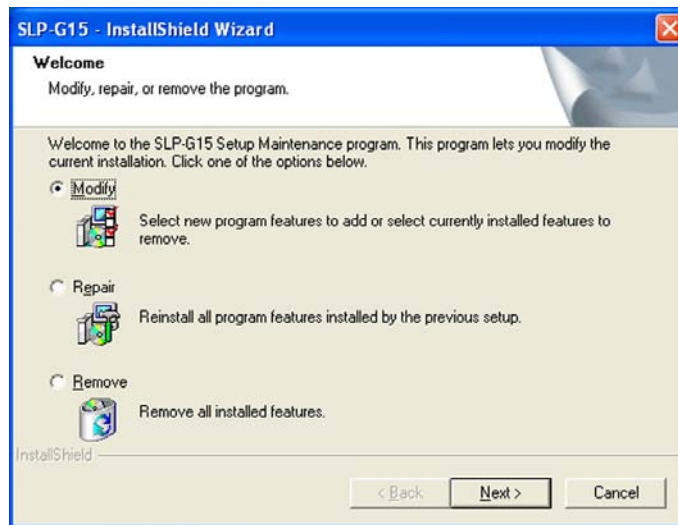

Modify

Select functions, and selectively install or remove GatewayEditor components and USB drivers.

Repair

If any program files have been removed accidentally, this function restores the system configuration to that of a new installation.

Remove

Executable files (GatewayEditor and USB drivers) of the SLP-G15 are removed.

 **Note**

Project files created by the user, address selection palette favorites, etc. are not removed.

! **Handling Precautions**

- If the installation destination folder or the program folder location for the Start menu, to which program icons are registered, is changed during an upgrade, blank folders may remain. In this case, remove the blank folders manually.
- If an installer program with a different version is run, the installation information from the old version may remain in the [Add/Remove Applications] (Add or Remove Programs) list. If Remove Programs is executed for this old information, no program will be removed, but the information will be deleted.
- After the “YAMATAKE (slabbus) USB” driver has been removed from [Add/Remove Applications] (Add or Remove Programs), even though the USB drivers are added using the [Modify] installation, the USB driver may not be installed. In this case, run the [Repair] installation.

8 - 3 Starting Up and Exiting GatewayEditor

■ Starting up GatewayEditor

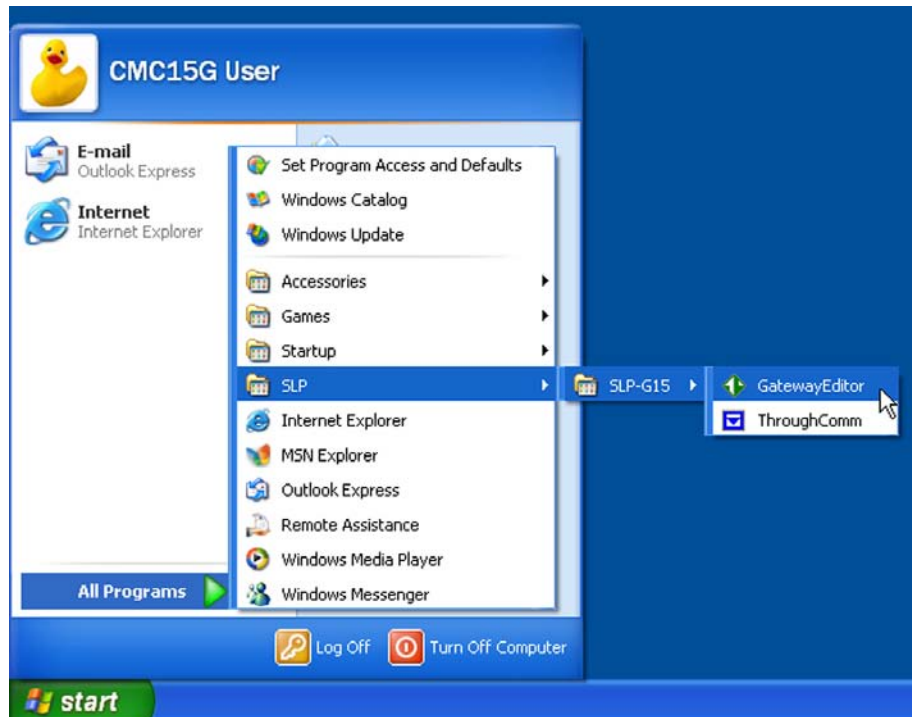

To start up GatewayEditor, follow the steps below.

Click the Windows [Start] button in the lower left of the screen.

Select [All Programs] → [SLP] → [SLP-G15] → [GatewayEditor].

>> GatewayEditor then starts up and the Menu window appears.

! Handling Precautions

Up to two instances of GatewayEditor can be run at the same time. If you attempt to start a third instance, an error message will appear.

■ Exiting GatewayEditor

To exit GatewayEditor, follow the steps below.

Click the [X] (close) button on the title bar. To exit GatewayEditor from the menu, select [Exit] from the [File] menu.

>> GatewayEditor will close.

📖 Note

You can copy or paste data between two instances of GatewayEditor while they are both running (“double-running”).

8 - 4 Operation Flow

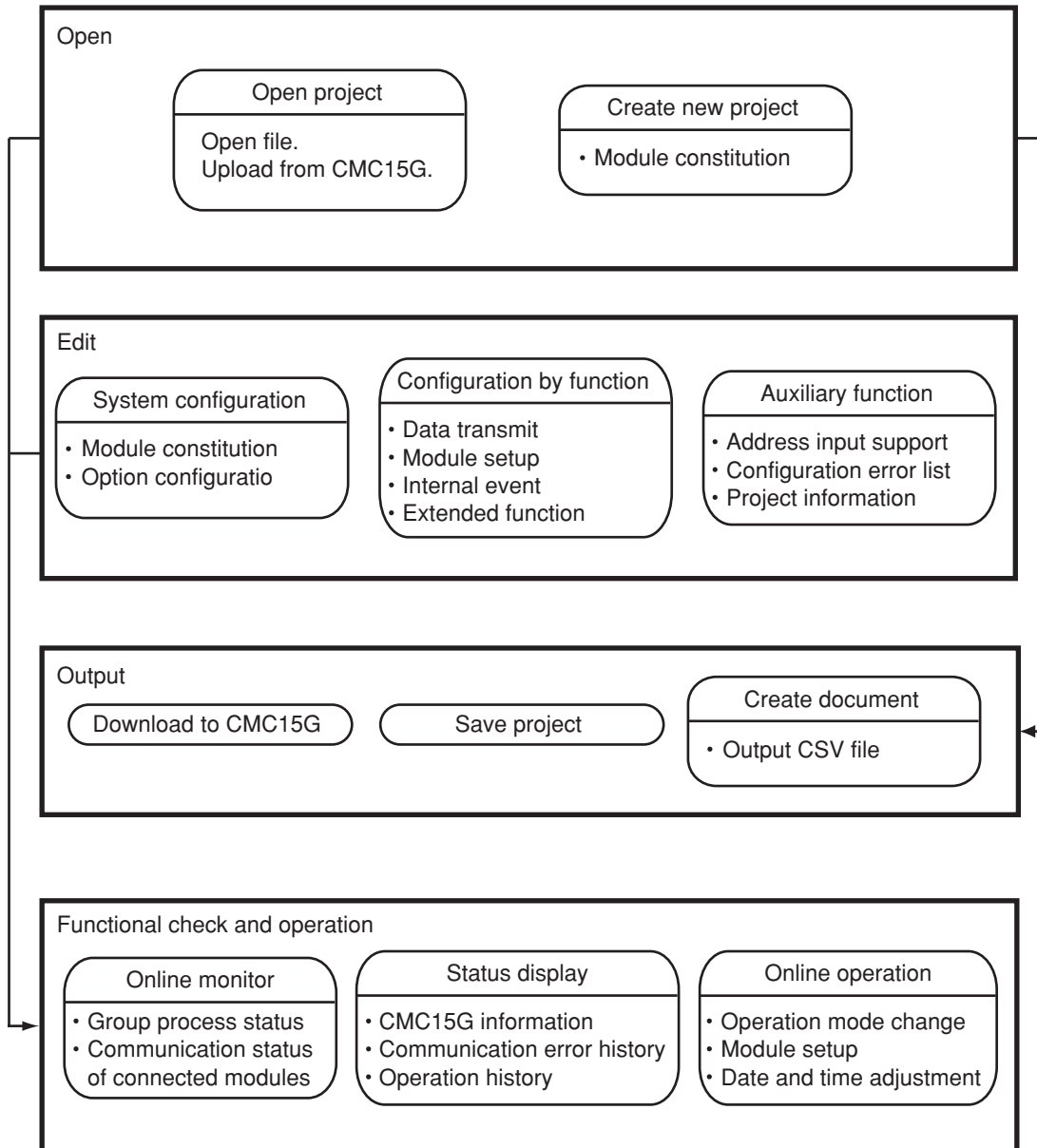

8 - 5 Configuration Functions

8-5-1 Main window

■ Screen structure

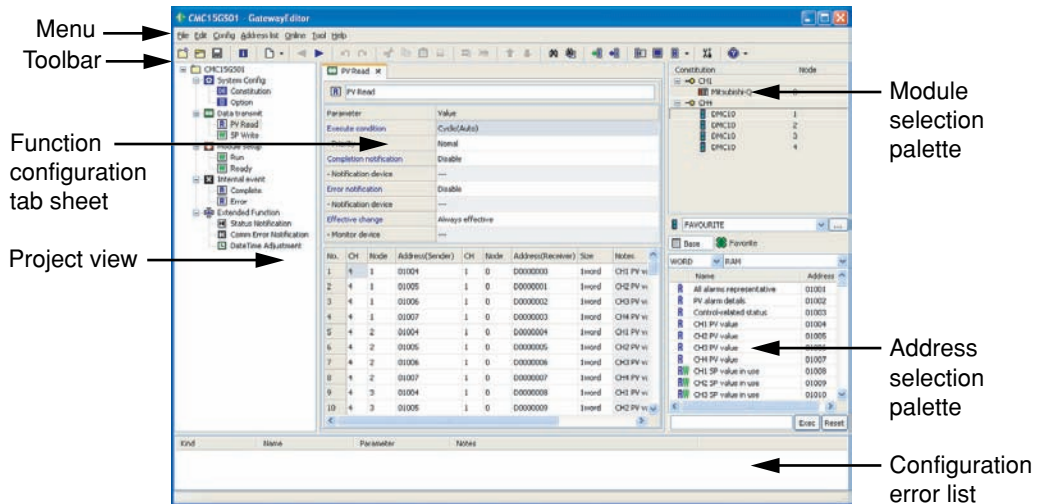

- **Menu**

Operational items are displayed on the menu.

- **Toolbar**

Buttons related to menu items are displayed.

- **Project view**

Function configuration items for the CMC15G are displayed in a tree view format.

- **Function configuration tab sheet**

A configuration sheet for each function is displayed as a tab sheet in list format.

- **Module selection palette, Address selection palette**

When a connected module is selected on the module selection palette, a list of addresses which can be input is displayed on the address selection palette.

To specify an address easily, drag it from the address selection palette and drop it into the device input box on the configuration sheet.

- **Configuration error list**

If any configuration is incorrect, the contents of relevant error are displayed.

- **Menu bar/Toolbar**

GatewayEditor functions are displayed on the menu bar and toolbar.





The following describes the conventions for each item name:

Icon	Icons indicate relevant functions in an easily understood way. Clicking an icon on the toolbar will execute the corresponding function.
Item name	An item name shown on the menu.
[Ctrl]+[X]	Displays a shortcut key ^{*1} . If a shortcut key is not available, no keys are displayed.













*1. Shortcut keys directly execute a menu item. They consist of [Ctrl] (or [Shift]) + a specified key. For example, pressing [c] when [Ctrl] is pressed executes the copy command.

■ **Menu descriptions**

















● **File menu**

Menu	Icon	Sub-menu	Description	Shortcut	
File		Create new project	Creates a new project.	[Ctrl] + [N]	
		Open project	Opens a saved project file (*.gwp).	[Ctrl] + [O]	
		Re-open project	Displays up to 10 names of the most recently opened files, along with their path (full directory location). Selecting a desired project file will open it.		
		Save project	Saves the currently opened project file.	[Ctrl] + [S]	
		Save project as	Saves the currently opened project with a user-specified file name.		
		Close project	Closes the currently opened project.		
		Export	CSV file	Outputs the settings of the currently opened project to a file in CSV format.	
		Project information		Displays the Project Information screen, allowing you to check key information for the currently opened project (internal memory usage status of the CMC, etc.).	
		Exit		Exits GatewayEditor.	



● Edit menu

Menu	Icon	Sub-menu	Description	Shortcut
Edit		Undo	Undoes your last action.	[Ctrl] + [Z]
		Redo	Redoes the last action that was undone.	[Ctrl] + [Y]
		Cut	Deletes the selected character string or item and moves it to the Clipboard.	[Ctrl] + [X]
		Copy	Copies the selected character string or item to the Clipboard.	[Ctrl] + [C]
		Paste	Pastes data from the Clipboard to the selected position.	[Ctrl] + [V]
		Clear	Clears the selected character string or item.	
		Select all	Selects all character strings or items.	[Ctrl] + [A]
		Delete	Deletes the selected item.	
		Insert line	Inserts a blank line at the selected position. The lines following the selected position are shifted down.	[Ctrl] + [Ins]
		Delete line	Deletes the selected line. Lines below the deleted line are shifted up to fill in the space left by the deleted line.	[Ctrl] + [Del]
		Insert sync line	Inserts SYNC showing the synchronous line at the selected position. The lines next to the selected position are shifted down.	
		Move up	Moves the selected item one line up.	[Ctrl] + [↑]
		Move down	Moves the selected item one line down.	[Ctrl] + [↓]
		Search	Displays a palette allowing you to find a specified character string.	[Ctrl] + [F]
	Replace	Displays a palette allowing you to replace the character string with a specified one.	[Ctrl] + [H]	















● Configuration menu

Menu	Icon	Sub-menu	Description	Shortcut	
Config		System Config	 Construction	Opens a system configuration window for the currently displayed project.	
			 Option		
		Extended Function	 Status Notification	Opens an extended functions configuration sheet for the currently opened project	
			 Comm Error Notification		
			 Date Time Adjustment		
		Create new sheet	 Data Transmit	Adds a new configuration sheet for the currently opened project.	
			 Module Setup		
			 Trend	Trend, Data Log, and Event Log sub-menus are displayed only when using the CMC15GD01 advanced model.	
			 Data Log		
			 Event Log		
			 Internal event		
		Open		Opens the item selected in the project view as function configuration sheet or configuration window.	
	Close		Closes the configuration sheet on top of the configuration sheets that are open on the function configuration tab sheet.	[Ctrl]+[W]	
	Close all		Closes all configuration sheets open on the function configuration tab sheet.		
	Show prev sheet		Closes the top configuration sheet open on the function configuration tab sheet and displays the contents of the previous configuration sheet. If the previous sheet is already open, the opened tab becomes active.	[Ctrl]+[]	
	Show next sheet		Closes the top configuration sheet open on the function configuration tab sheet to display the contents of the next configuration sheet. If the next sheet is already open, the opened tab becomes active.	[Ctrl]+[]	
	Change name		Displays the “Change Group Name” window, allowing you to change the group name of the configuration sheet selected in the project view.		

● Address list menu

Menu	Icon	Sub-menu	Description	Shortcut
Address list		Add to favorite	Adds the item selected on the address selection palette to the favorites palette.	
		Delete from favorite	Deletes the item selected on the address selection palette from the favorites palette.	
		Edit favorite list	Displays a window allowing you to edit the favorites list by model type selected on the module selection palette.	







● Communication menu

Menu	Icon	Sub-menu	Description	Shortcut						
Online		Download PC → CMC15G	Transmits the project to the CMC15G main unit.							
		Upload to CMC15G → PC	Transmits the project running on the CMC15G main unit to the personal computer.							
		CMC15G information	Reads out information (version or history) from the CMC15G main unit.							
		Online monitor	Displays the Online monitor screen, allowing you to check the process status of the CMC15G function or the status of communication with the connected modules.							
		Online operation	<table border="1"> <tr> <td></td> <td>Mode change</td> </tr> <tr> <td></td> <td>Online Setup Module</td> </tr> <tr> <td></td> <td>Online Adjust Date Time</td> </tr> </table>		Mode change		Online Setup Module		Online Adjust Date Time	Executes an operation (operation start/stop, etc.) on the CMC15G.
	Mode change									
	Online Setup Module									
	Online Adjust Date Time									

● Tool menu

Menu	Icon	Sub-menu	Description	Shortcut
Tool		Environment	Configures the GatewayEditor environment (communication with the PC, etc.).	
		Change Target Model	Changes the target model of the project currently being edited.	
		Update System on CMC15G	Updates the system of the connected CMC15G.	

● Help menu

Menu	Icon	Sub-menu	Description	Shortcut					
Help		Help	<table border="1"> <tr> <td></td> <td>Configuration Manual</td> </tr> <tr> <td></td> <td>Communication Manual</td> </tr> </table>		Configuration Manual		Communication Manual	Displays the user's manual (PDF file).	
			Configuration Manual						
	Communication Manual								
	Version		Displays version information for the GatewayEditor.						

8-5-2 Project view

Settings for CMC15G functions are displayed in a tree view format.

You can configure each function from the project view.

The CMC15GD01 advanced model displays the logging function items in addition to the items for the standard model.

■ Screen structure

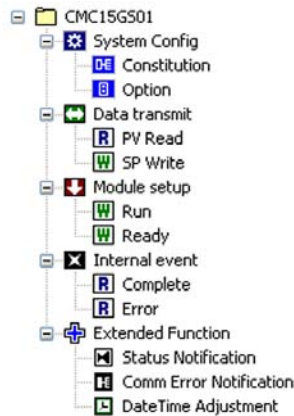

Standard model (CMC15GS01)

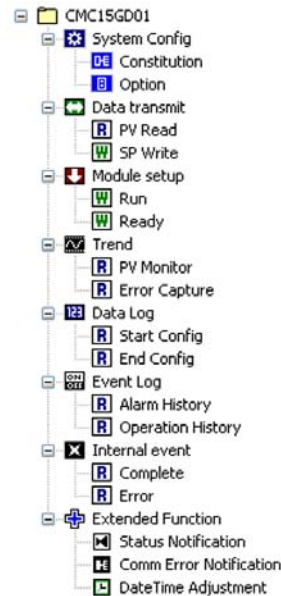

Advanced model (CMC15GD01)

■ Structure list

Project

Uppermost item in the project.

Up to 32 characters of the project file name are displayed.

If the project has not been saved to a file, “New project” is displayed.

System setting

Displays the system configuration items for the CMC15G.

- Constitution : Configures the modules to be connected to the CMC15G.
- Option : Configures CMC15G options.

Data transmit

Displays the configurable items for data transmission. Up to 200 configuration sheets are available for each group that is a process unit.

Icons and configuration sheet names are displayed in the project view.

The user can select a configuration sheet icon by function from the following icons:

Normal

Read

Write

Read/Write

Handling Precautions

Icons identify the process contents of each configuration. They cannot specify the operation of the CMC15G.

Module setup

Displays the configurable items for module setup. Up to 200 configuration sheets are available for each group that is a process unit.

The icon and configuration sheet name are displayed in the project view.

The icon is “ Write”

Trend

Displays the configurable trend items for the CMC15GD01 advanced model.

Displays the configurable items for module setup. Up to 20 configuration sheets are available for each group that is a process unit.

The icon and configuration sheet name are displayed in the project view.

The icon is “ Read”

Data Log

Displays the configurable data log items for the CMC15GD01 advanced model.

Displays the configurable items for module setup. Up to 20 configuration sheets are available for each group that is a process unit.

The icon and configuration sheet name are displayed in the project view.

The icon is “ Read”

Event Log

Displays the configurable event log items for the CMC15GD01 advanced model.

Displays the configurable items for module setup. Up to 20 configuration sheets are available for each group that is a process unit.

The icon and configuration sheet name are displayed in the project view.

The icon is “ Read”

Internal event



Displays the configurable items for internal events. Displays the configurable items for module setup. Up to 20 configuration sheets are available for each group that is a process unit.

The icon and configuration sheet name are displayed in the project view.

The icon is “ Read”

Extended Function

Displays the configurable items for extended functions. The following are available:

-  Status Notification: Settings for notifying the host station of the status of the CMC15G.
-  Comm Error Notification: Settings for notifying the host station of a communication error between the CMC15G and a connected module.
-  Data Time Adjustment: Settings for synchronization of CMC15G date and time with the date and time of the host station.

■ Creating a configuration sheet

There are two ways to create a configuration sheet:

● Creating from a pop-up menu

To create a configuration sheet using a pop-up menu (right-click a function name) in the tree view, follow the steps below.

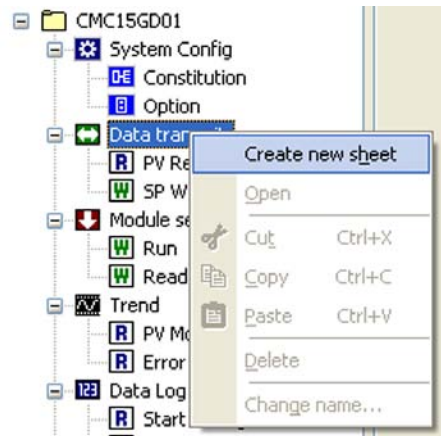

- Procedures

- (1) In the project view, select the function for which you want to create a configuration sheet.
- (2) Select [Create new sheet] from the pop-up menu.

● Creating from the main menu

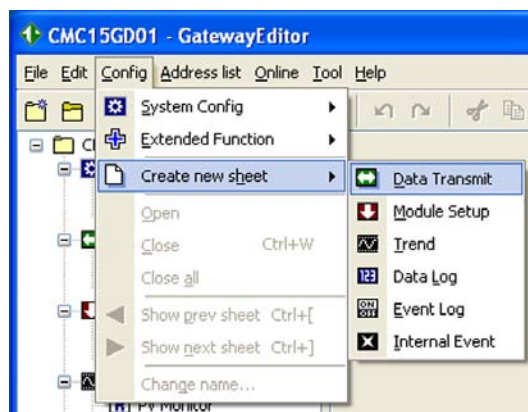

To create a new configuration sheet from the main menu, follow the steps below.

- Procedures

- (1) Select [Create new sheet] from [Config] on the main menu.
- (2) Select the function item corresponding to the new sheet you want to create.

■ Opening a configuration sheet

Two ways to display multiple configuration sheets are described below.

● Opening a configuration sheet using the individual function configuration tab sheet

Multiple tab sheet displays can be changed quickly to display a desired sheet.

To open a configuration sheet using the individual function configuration tab sheet, follow the steps below.

- Procedures

- (1) Select the configuration sheet you want to open in the project view.
- (2) Select [Open] from the pop-up menu or double-click the selected configuration sheet.

Up to 100 sheets can be opened on the function configuration tab sheet at the same time.

● Opening a configuration sheet using one function configuration tab sheet

When editing multiple sheets, it is not necessary to open or close the function configuration tab sheet many times.

To change the configuration sheet and open it using one function configuration tab sheet, follow the steps below.

- Procedures

- (1) Select the configuration sheet you want to open first in the project view.
- (2) Select [Config] → [Show next sheet] or [Config] → [Show prev sheet].

>> Open the next (or previous) configuration sheet on the function configuration tab sheet currently being opened. If the next sheet (or previous sheet) is already opened, the tab moves to the open tab. You cannot open across functions, such as data transmission or module setup. If the last (or top) sheet is open, the next (or previous) sheet cannot be opened.

■ Editing a sheet

To edit a configuration sheet (cut, copy, paste, or delete, etc.), select a function from the pop-up menu or main menu in the same manner as described for creation of a new sheet.

● Selecting multiple sheets

You can select multiple configuration sheets to move or copy multiple sheets at once.

- Area selection

- Operation with the mouse

- (1) Select the configuration sheet on top (i.e., the last one) in the project view area.
- (2) With the [Shift] key pressed, click the last configuration sheet (the one on top) in the area.

- Operation from the keyboard

- (1) Select the configuration sheet on top (i.e., the last one) in the project view area.

(2) With the [Shift] key pressed, press [↑] or [↓] to specify the top (or last) in the area.

• “Random” selection

• Operation with the mouse

(1) Select a configuration sheet in the project view.

(2) With the [Ctrl] key pressed, click multiple configuration sheets you want to select.

● Changing the order

You can change the order of configuration sheets under the same function (Data transmit, Module setup, etc.).

• Operation with the menu (toolbar)

(1) Select a configuration item in the project view.

(2) To move the cursor one line up, select [Move up] from [Edit] in the main menu.

(3) To move the cursor one line down, select [Move down] from [Edit] in the main menu.

● Changing the group name

You can change the configuration sheet name.

• Procedures

(1) Select a configuration sheet in the project view.

(2) Select [Change name] from the pop-up menu (or [Change name] from [Config] on the main menu).

>> The “Change Name” window will appear.

(3) To change the name, input a group name in the “name setup” box.

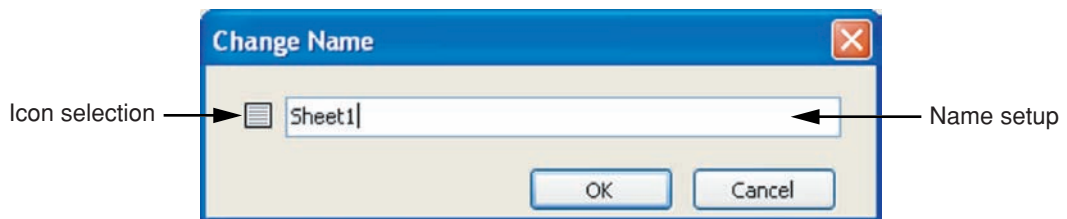

(4) To change the icon, click [Icon Selection] to display a pull-down menu. Select the icon you want to change.

(5) Click the [OK] button.

! Handling Precautions

- Up to 32 characters can be input.
- You can change the icon only when [data transmit] is selected.
- Icons are intended to identify the process contents of each configuration. Changing the icon (e.g., read → write) will not change the underlying operation.

8-5-3 Function configuration tab sheet

Each function sheet is displayed as a tab sheet in list format.



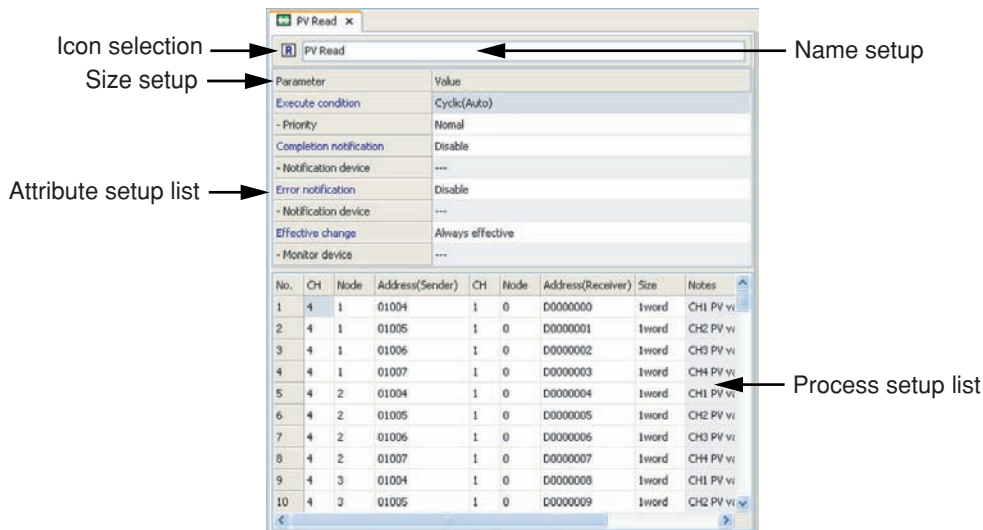

■ Screen structure



● Icon selection



Selects the icon that is displayed in the project view. Only the icons for data transmission can be selected (changed) by the user.

Depending on the desired process, select one of the following icons:

-  Normal
-  Read
-  Write
-  Read/Write

To create a new sheet, select the “Standard” icon.

For processes other than data transmission, the following icons are used. The icons cannot be changed.

- Module setup :  Write
- Internal event :  Read
- Logging functions :  Read

Handling Precautions

- Icons are intended to identify the process contents of each configuration. Changing the icon (e.g., read → write) will not change the underlying operation.

● Name setup

Displays the group name.

Up to 32 characters can be input.

● Size setup

When using the CMC15GD01 advanced model, the size of the backup memory used for trends, data logs, and event logs is displayed.

The size used for each group can be changed using the track bar.

The usage ratio is displayed on the bar graph. If usage exceeds the upper limit, it is displayed in red.

Light green (light red): size used for the target group.

Dark green (dark red): size used for other groups.

The track bar can be moved in the settable area. The upper limit value of the track bar setting is updated if any of the following occurs:

- The sheet is opened.
- An attribute is changed.
- Operation settings are changed.
- Tab sheet is changed.
- If the attribute is changed directly or if the setting already exceeds the upper limit when the paste, cut, or delete operations are used in the project tree view, the size which is set at this time is used as the upper limit.

● Attribute

Basic operations (startup conditions or notification process) of the group process are listed.

The contents you can set up may vary depending on the type of function.

For details, refer to

 each function stated in section 9-3, Basic Function Configuration.

● Operations

Operations related to the process to be executed by the group are displayed in list format.

The contents you can set up may vary depending on the type of function.

For details, refer to

 each function stated in section 9-3, Basic Function Configuration.

Note

The background of a cell having a configuration error is displayed in light red. The background of a cell having a blank initial value or for which no value has been input is displayed in light yellow.

■ Operating procedures

● Clear

- Procedures

(1) Select a line in the configuration list.

(2) Select [Clear] from the pop-up menu (or [Clear] from [Edit] on the main menu).

● Insert line

- Procedures

(1) Select a line in the operations list.

Clicking the fixed cell with the desired No. will select the line.

(2) Select [Insert line] from the pop-up menu (or [Insert line] from [Edit] on the main menu).

Note

If multiple lines are selected before the Insert line command is executed, an equal number of blank lines is inserted before the top line of the selected area.

● Delete line

- Procedures

(1) Select a line in the operations list.

Clicking the fixed cell with the desired No. will select the line.

(2) Select [Delete line] from the pop-up menu (or [Delete line] from [Edit] on the main menu).

● Search

- Procedures

(1) Select [Search] from [Edit] on the main menu.

>>The following palette is displayed below the operations list:



(2) Input a character string to be searched for in the [Input search character string] box.

(3) To search downward, click the [Next] button.

To search upward, click the [Prev] button.

(4) To exit the search process and close the palette, click the [X] button.

! Handling Precautions

The character string in the cell must match the search string perfectly.

📖 Note

When a cell area has been specified beforehand, the search is executed only in the specified area.

● **Replace**

- Procedures

(1) Select a line in the operations list.

Clicking the fixed cell with the desired No. will select the line.

>>The following palette is displayed under the list:



(2) Select [Delete line (N)] from the pop-up menu (or [Delete line] from [Edit] on the main menu).

(3) Input the character string to be replaced in the [Input replace character string] box.

(4) When the [Exec] button is clicked, the cursor moves to the first cell containing a matching character string.

(5) Click the [Exec] button again. The character string is replaced, and the cursor moves to the next cell with a matching character string.

(6) If the [All] button is clicked, all matching character strings in the operations list are replaced.

(7) To exit the replace process and close the palette, click the [X] button.

! Handling Precautions

The character string in the cell must match the search string perfectly.

📖 Note

- If you do not wish to replace the character string in a particular cell, you can skip it without replacement by clicking the [Next] or [Prev] button. The cursor will move to the next cell that contains a match, without making a replacement.
- When a cell area has been specified beforehand, replacements are made only in the specified area.

8-5-4 Module selection palette and address selection palette

Models connected in the module constitution and their addresses are displayed in list format.

■ Screen structure

● Base page

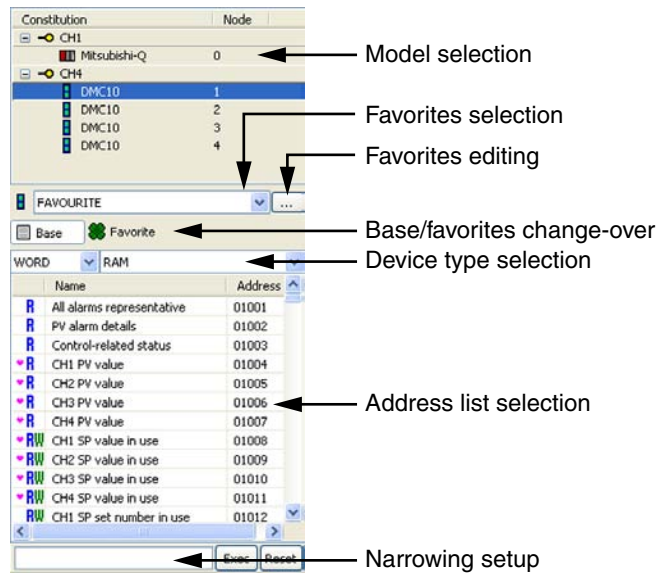

● Favorites

Favorites lists contain data that the user uses frequently. A favorites list or multiple lists can be created for each model, making data easily available when inputting addresses into configuration sheets.

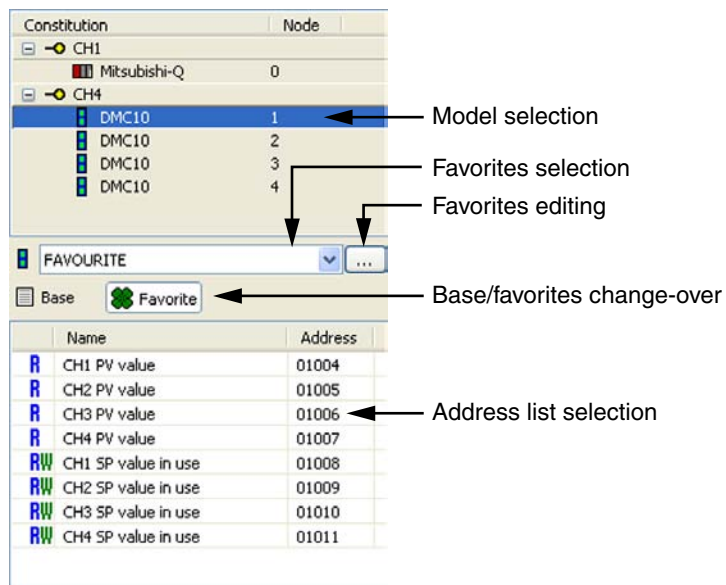

● **Model selection**

Connected modules are displayed in tree view format. You can select multiple items in the same layer. Selection of multiple items in the tree view is done in the same way as selection of multiple configuration items in the project view.

● **Favorites selection**

If multiple favorites lists are registered for one model, you can select the one you wish to display in the address list selection area from this drop-down list.

● **Favorites editing**

Displays the Edit Favorite List window, which allows you to edit the favorites for the selected model.

● **Base/favorites change-over**

If “Base” is selected, all addresses for the selected module are displayed in the address list selection area. If “Favorite” is selected, only addresses registered in the favorites list are displayed.

● **Device type selection**

The device type selection is displayed only when “Base” is selected in the base/favorite change-over box. The contents of the items displayed for device type selection vary depending on the selected model.

● **Narrowing setup**

The narrowing setup is displayed only when “Base” is selected in the base/favorite change-over area. Only addresses including the specified character string are displayed in the address list selection area.

 **Note**

GatewayEditor favorites can be shared by users logged on to the personal computer. For example, if a user who logs on as “tanaka” creates a favorites list, another user who logs on as “suzuki” can use the same favorites.

 **Handling Precautions**

GatewayEditor favorites are saved when you exit GatewayEditor. Note that if two instances of GatewayEditor are running, the favorites of the GatewayEditor instance that is exited last will overwrite the previously saved favorites.

(1) Host station (PLC, etc.) and general communication module

Select a device type and scroll the address with the up or down button in the device area. Additionally, you can input an address directly.

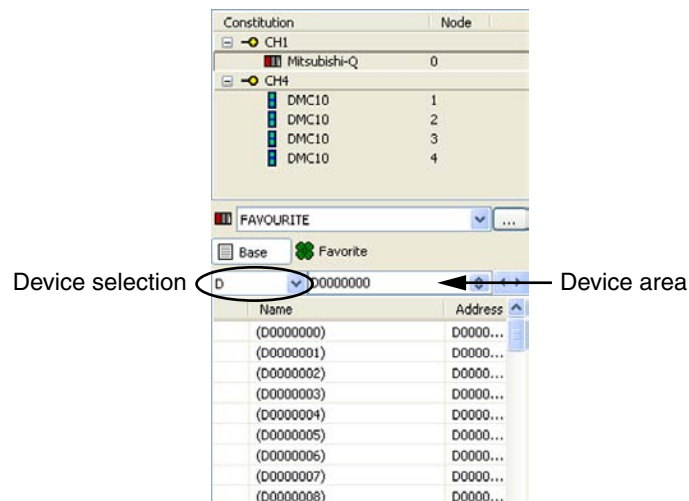

(2) Slave station (SDC-series, DMC10, CMQ-V, etc.)

As you select the next item, you can change the address that is displayed in the address selection list.

- Bit/Word
- RAM/ROM

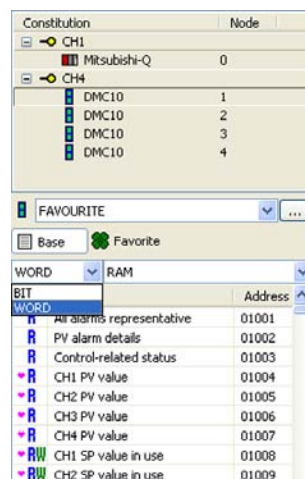

! Handling Precautions

Some modules, such as temperature controllers, allow you to select whether to write to RAM or to ROM (EEPROM). When writing to the ROM is selected, the written value is saved even after the power has been turned ON again, but the number of write cycles is limited. For details, refer to the user's manual for the relevant module.

● **Address list selection**

Addresses selected in the module selection area are displayed in list format.

One of the icons below is displayed to the left of each address item.

 : Data can be read or written from/to the address.

 : Data can only be read from the address.

 : Data can only be written to the address.

For items registered as favorites at the displayed address, a heart () is shown to the left of the icon.

■ Operating procedures

● Drag & Drop

By dragging an item from the address list selection area and dropping it into the function configuration tab sheet, you can set up addresses easily.

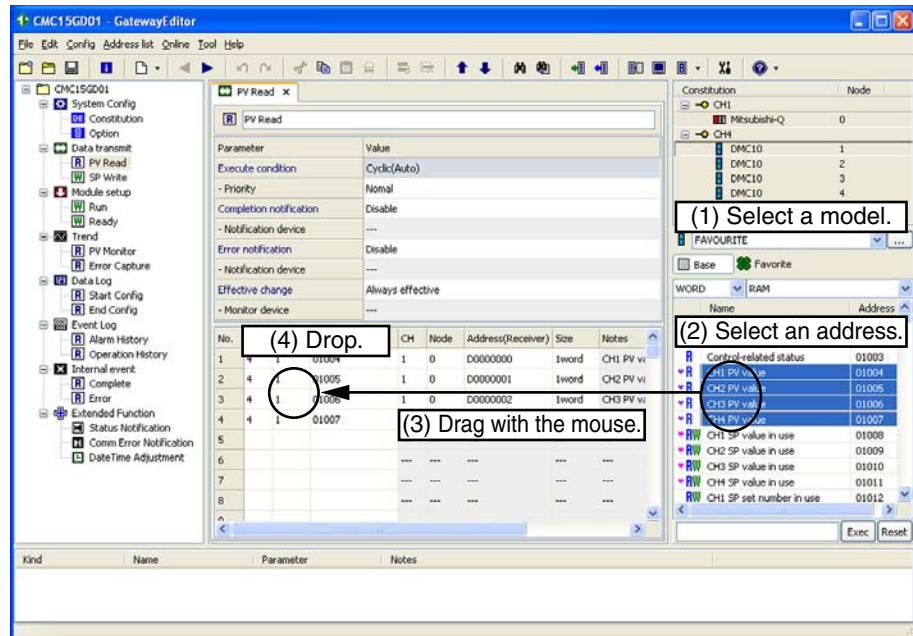

• Procedures

- (1) Select a desired module for input in the model selection area.
- (2) Select an address to be input in the address list selection area.
- (3) Press the left mouse button on the selected item and keep it pressed while moving the mouse cursor to the desired input position in the operations list.
- (4) Release the mouse button on an item in the operations list, to which an address is input.

● Copy & Paste

You can input information selected in the address list onto the function configuration tab sheet using the copy and paste function.

- (1) Select a desired module for input in the model selection area.
- (2) Select an address to be input in the address list selection area.
- (3) Select [Copy] from the pop-up menu. Or, select [Edit] → [Copy] from the main menu.
- (4) On the item in the operations list, to which you wish to input and address, select [Paste] from the pop-up menu, or select [Paste] from [Edit] on the main menu.

● Setting up narrowing conditions

By narrowing down the items displayed in the address list selection area, you can find a desired address easily.



- (1) Select the desired module in the model selection area.
- (2) Select “Base” in the Base/Favorite change-over area.
- (3) In the [Narrowing character string setup] box, input a word to refine the list of items shown.
- (4) Click the [Exec] button or press the [Enter] key.

The list is refined, and only addresses containing the search term are displayed in the address list.

- (5) Click the [Reset] button or click the [Exec] button with the [Narrowing character string setup] box blank to cancel the narrowing search term.

Note

- You can input multiple search terms separated by a space in the [Narrowing character string setup] box. Refinement of the list is done with an AND relation between the search terms.
- When narrowing is cancelled, the list reappears as it was before narrowing began. If a different model is selected or the device type is changed, narrowing is cancelled.

● Adding an address to the favorites

To add an address that is displayed in the “Base” area of the address selection list to the favorites list for any model, follow the steps below.

- (1) Select the desired module in the model selection area.
- (2) Select “Base” in the Base/Favorite change-over area.
- (3) Select an address you want to add to the favorites list.
- (4) Select [Add to favorite] from the pop-up menu or select [Add to favorite] from [Address List] on the main menu.

Note

- Favorites can be registered for each model. If the same model is assigned to multiple channels, the favorites list can be used on all of them.
- Select a desired favorites list from the favorites selection area only if multiple favorites lists exist for one model. by default, the address will be registered to FAVORITE.

- **Deleting an address from a favorites list**

To delete an address displayed as a favorite in the address selection list, follow the steps below.

- (1) Select the desired module in the model selection area.
- (2) Select the address you want to delete from the favorites list.
- (3) Select [Delete to favorite] from the pop-up menu or select [Delete to favorite] from [Address List] on the main menu.

- **Rearranging addresses**

- **Sorting addresses**

You can sort addresses by the icon column, name column, or address column in the icon address list selection area.

- Procedures

- (1) Click the fixed cell at the top of any column in the address list selection area.
- (2) The listed data is sorted in ascending order.
- (3) Click the fixed cell again to sort the data in descending order.

- **Moving up or down**

Items in the address list selection area can be moved up or down by following the steps below.

- (1) Select the item you want to move.
- (2) Select [Move up] from the pop-up menu or from [Edit] on the main menu.
- (3) Select [Move Down] from the pop-up menu or from [Edit] on the main menu.
- (4) The selected item will move up or down.

- **Editing the favorites list**

Favorites lists for one model can be added, deleted, or renamed in the Edit Favorite List window.

To open the Edit Favorite List window, click the [Edit Favorite List] button, select [Edit Favorite List] from the pop-up menu, or select [Edit Favorite List] from [Address List] on the main menu.

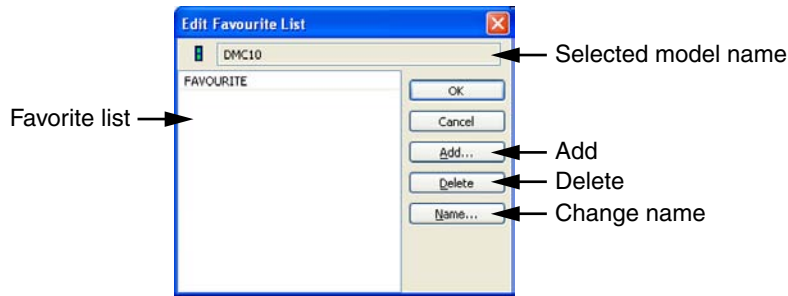

• **Selected model name**

The name of the model connected to the favorites list is displayed. You cannot edit the model name.

• **Favorite list**

The list of favorites registered for the selected model is displayed.

 **Note**

- One or more favorites lists must be defined for each model.
- FAVORITE is the favorites list defined for each model by default. If you do not make changes to the favorites setup, favorites are added to FAVORITE.

• **Add**

- Procedures

(1) Click the [Add...] button.

>> The following Add list window will appear:

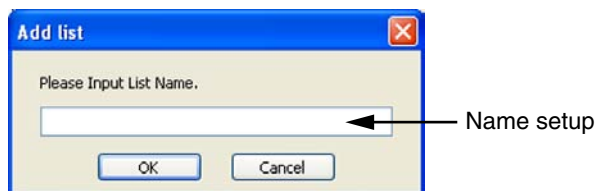

(2) In the name setup box, input the name of the favorites list you wish to create.

(3) Click [OK]. A new favorites list is then added.

• **Delete**

- Procedures

(1) In the list of favorites lists, select the one you wish to delete.

(2) Click the [Delete] button.

>> A deletion confirmation dialog box will appear.

(3) Click the [OK] button to delete the selected favorites list.

- **Change Name**

- Procedures

- (1) In the list of favorites lists, select the list you wish to rename.
- (2) Click the [Name...] button or double-click the favorites list you have selected in the favorites list. The Change Name window will appear.

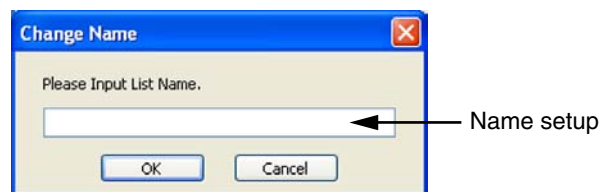

- (3) Input a new name in the name setup box.
- (4) Click the [OK] button. The name of the favorites list is then changed.

- **Selecting multiple addresses**

- **Contiguous item selection**

- Procedures

Selection with the mouse

- (1) Select the first of the contiguous items in the address list selection area.
- (2) While pressing the [Shift] key, click the last of the items you wish to select.

Selection with the keyboard

- (1) Select the first of the contiguous items in the address list selection area.
- (2) While pressing the [Shift] key, press the [↑] or [↓] key to select contiguous items.

- **"Random" selection**

- Procedures

Selection with the mouse

- (1) Select an item on the address list selection.
- (2) While pressing the [Ctrl] key, click further items you wish to add or delete.

• **Multiple-selection operation**

When selecting multiple modules or addresses to set them, the node addresses or addresses are allocated automatically. To allocate node addresses or addresses, follow the steps below.

Example 1. Selecting multiple addresses

If you select communication CH“4” and address “1001 to 1003” of the module with node “1” from the module selection:

(1) Selection status

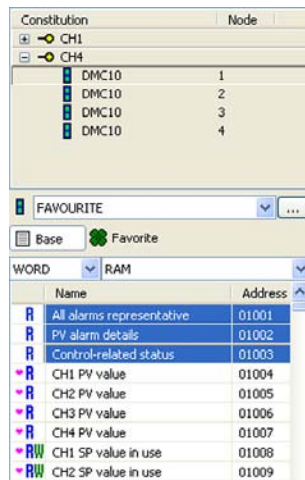

(2) Results after dragging and dropping on the function configuration tab sheet.

CH	Node	Address
4	1	1001
4	1	1002
4	1	1003

Example 2. Selecting multiple modules

If you select communication CH “4” and address “1001” of the module with node “1 to 3” from the module selection:

(1) Selection status

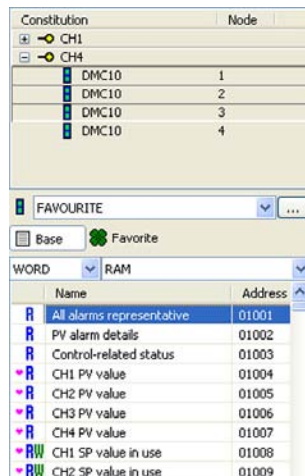

(2) Results after dragging and dropping on the function configuration tab sheet.

CH	Node	Address
4	1	1001
4	1	1002
4	1	1003

Example 3. Selecting multiple addresses and modules

If you select communication CH “4” and address “1001 to 1003” of the module with node “1 to 3” from the module selection:

(1) Selection status

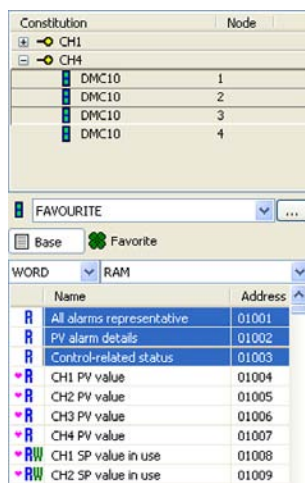

(2) Results after dragging and dropping on the function configuration tab sheet.

CH	Node	Address
4	1	1001
4	1	1002
4	1	1003
4	2	1001
4	2	1002
4	2	1003
4	3	1001
4	3	1002
4	3	1003

8-5-5 List of configuration errors

If there is any incorrect configuration in the function configuration tab sheet, the contents of the error are displayed in the list of configuration errors.

The following information is displayed for errors:

- Configuration type (data transmission or module setup, etc.)
- Group name (only when the name is set.)
- Error details

Configuration errors include the following:

- The address is incorrect. (The address of the CPL is set for the communication channel to which the MELSEC-Q is assigned.)
- The numeric value exceeds the allowable input range.
- No data was input.

If there is a configuration error, the configuration cannot be transmitted to the CMC15G.

To move to the portion having the configuration error, follow the steps below.

- (1) Double-click the line for which the error is displayed or select the relevant line and press the [Enter] key.
- (2) The target configuration sheet is displayed and the focus is moved to the cell, in which the error occurs.

 **Note**

- Up to 300 errors can be displayed at once.

Chapter 9 WORKING WITH GATEWAYEDITOR

9 - 1 Creating a Project

A project is a group of functional settings for the CMC15G. Once a project has been downloaded to the main unit, CMC15G functions are available.

9-1-1 Creating a new project

- Procedures

(1) Select [Create new project] from the [File] menu.

>> The Module Constitution window will appear.

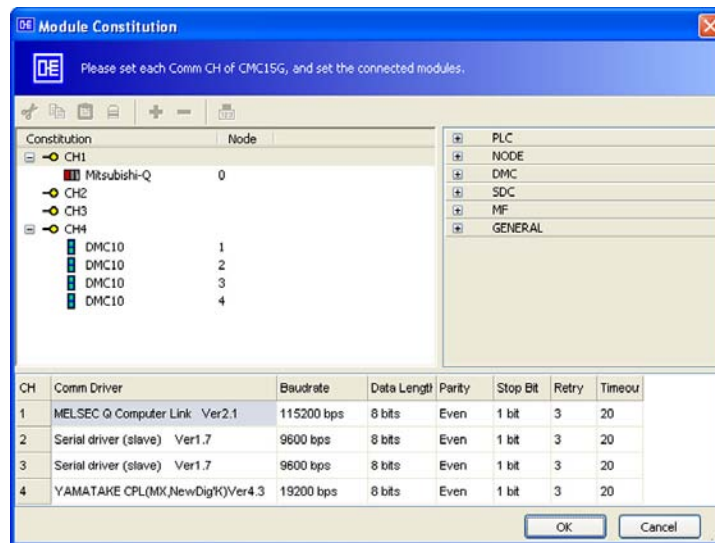

(2) Set up the module so that it is connected to the CMC15G.

👉 9-2-1, Module constitution (on page 9-9)

(3) Click the [OK] button.

>> A new project will be created.

Note

You can change the module constitution settings later. Therefore, it is not necessary to make all the settings completely at first.

9-1-2 Opening a project

- Procedures

(1) Select [Open project] from the [File] menu.

>> The Module Constitution window will appear.

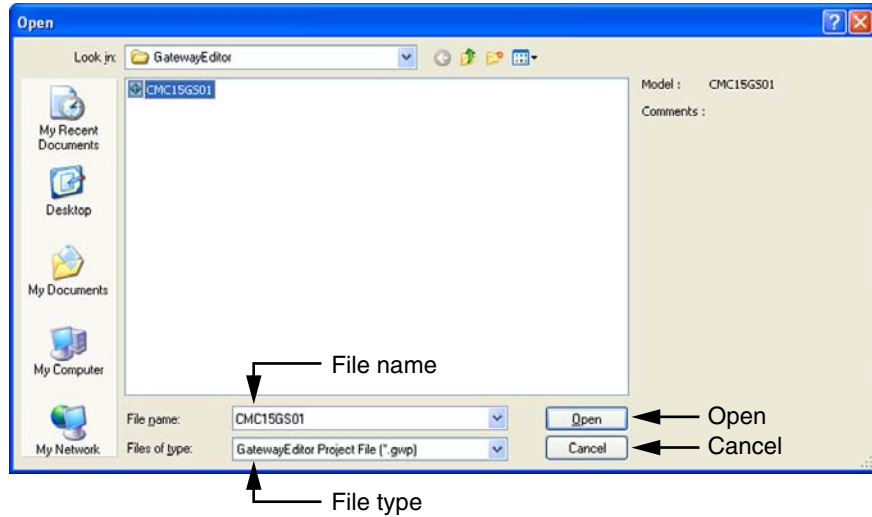

(2) Select the name of the file you want to open. (To specify a file name directly, input a file name in the [File name] box.)

(3) Click the [Open] button.

>> The project file you have specified will be opened.

Note

The default initial folder when starting up for the first time is “My Documents \GatewayEditor\.”

In subsequent startups, the folder selected the previous time appears as the initial folder.

If you select a project file, you can view the comments for that project.

9-1-3 Re-opening a project

- Procedures

(1) Select [Re-open project] from the [File] menu.

>> A window showing the list of projects opened in the past appears.

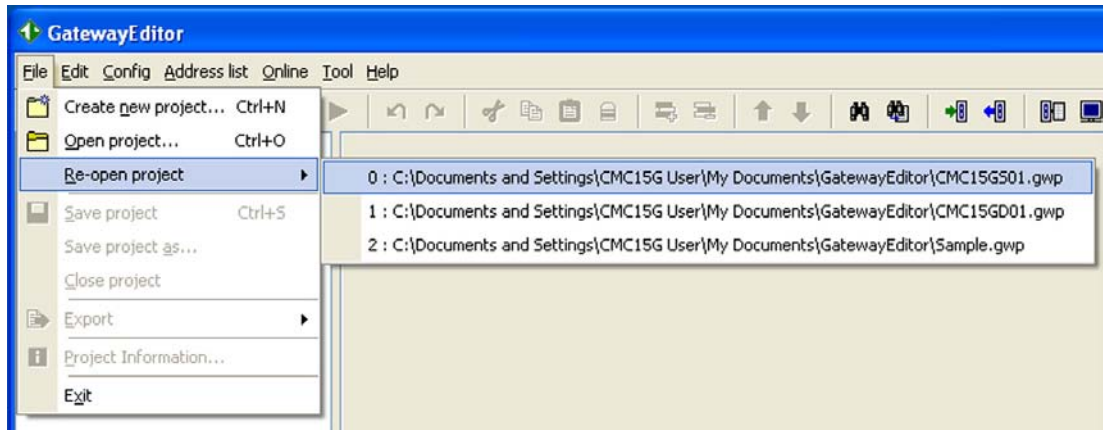

(2) Click the [Open] button.

>> The project file you have specified will be opened.

9-1-4 Saving a project

- Saving a project

- Procedures

Select [Save project] from the [File] menu.

>> The currently selected project is saved to a file.

 **Note**

If you attempt to save a project that has not yet been saved to a file, the Save As window will appear.

- Saving a project with a desired file name

- Procedures

(1) Select [Save project as] from the [File] menu.

>> The Save As window appears.

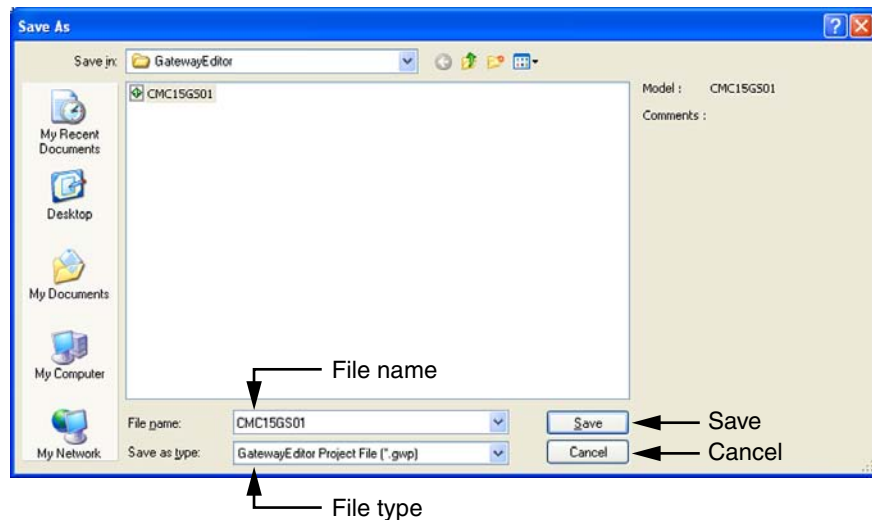

(2) Open the folder to which you wish to save the project, and input the file name.
(If you want to overwrite the project onto an existing file, select the file.)

(3) Click the [Save] button.

>> The project is saved with the specified file name.

 **Note**

The default initial folder when starting up for the first time is “My Documents \GatewayEditor\.”

In subsequent startups, the folder selected the previous time appears as the initial folder.

 **Handling Precautions**

To ensure that the project is saved properly, do not use any special Unicode characters in the file name.

9-1-5 Closing a project

- Procedures

Select [Close project] from the [File] menu.

>> The opened project will be closed.

Note

If you close a project you are currently editing, the following message will appear:

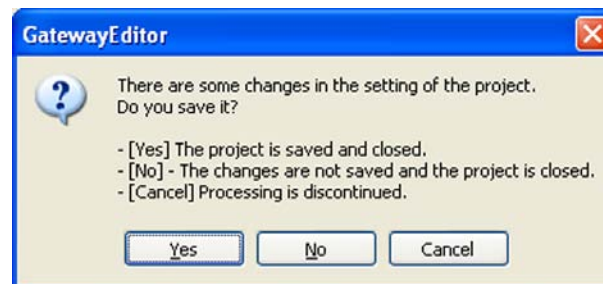

9-1-6 Checking the project information

- Procedures

Select [Project Information] from the [File] menu.

>> The Project Information window will appear.

■ General

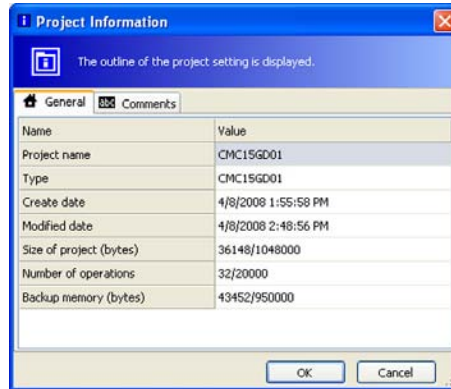

- **Project name**

Displays the project name.

- **Type**

Displays the target type applicable to the project.

- **Create date**

Displays the date and time when the project was created.

- **Modified date**

Displays the date and time when the project was saved.

- **Size of project (bytes)**

Displays the size of data saved to the CMC15G. If this size exceeds the maximum size (1048000 bytes), it is displayed in red.

- **Number of operations**

Displays the total number of operations set for the data transmission or module setup, etc. If the number of operations exceeds the maximum level (20000), it is displayed in red.

- **Backup memory (bytes)**

Displays this information only when using the CMC15GD01 advanced model. The size of the backup memory used for the trend, data log, and event log is shown. If this size exceeds the maximum level (950000 bytes), it is displayed in red.

! Handling Precautions

If the project size, number of operations, or backup memory exceeds the maximum level, the project cannot be downloaded to the CMC15G.

■ Comment

You can add a comment to the project. A comment can be up to 256 characters in length.

9-1-7 Outputting a CSV file

The contents of the project are output to a file in CSV format.

■ Output contents

● Project information

Project name	File name of project
Model No.	CMC15G*01A00
Comment	Comment about the project

● Module constitution

The following information is output by communication channel:

• Communication channel configuration

Parameters	Value
CH	1 to 4
Communication driver	Driver name
Band rate	600 to 115200 bps
Data length	8bits/7bits
Parity	None/even/odd
Stop bit	1bit/2bits
Retry	0 to 15
Time-out	1 to 255 (100ms)

• Connected module configuration

No.	Name	CH	Node	Sub
1	Model	1 to 4	0 to 127	0 to 127
2	Model	1 to 4	0 to 127	0 to 127
⋮	⋮	⋮	⋮	⋮

● Option configuration

Parameters		Value
Node address		1 to 126
Startup delay		Disable/Enable
Delay time (s)		1 to 360
Protect log table		Disable/Enable
Password		*****
Trigger device initialization	Data transmission	Disable/Enable
	Module setup	Disable/Enable
	Date & time adjustment	Disable/Enable
	Captured trends	Disable/Enable
	Data log	Disable/Enable
Notification device initialization	Data transmission	Disable/Enable
	Module setup	Disable/Enable

● Basic function configuration

The configuration of the following functions is classified into operation settings and operations. They are output by group. However, note that a function not in use is not output.

- Data transmission
- Module setup
- Internal event

The contents which are output are the attribute list and the operations list for each function.

● **Logging function configuration**

The configuration of the following functions is classified into operation settings and operations. They are output by group. However, note that a function not in use is not output.

- Trend
- Data log
- Event log

The contents which are output are the attribute list and the operations list for each function.

● **Extended function configuration**

The configuration of the following functions is output. However, note that a function not in use is not output.

- Internal status notification
- Communication error notification
- Date & time adjustment

The contents which are output are the attribute list and the operations list for each function.

■ **Outputting to a CSV file**

- (1) From the [File] menu, select [Export] → [CSV file].
 >> The Save As window appears.

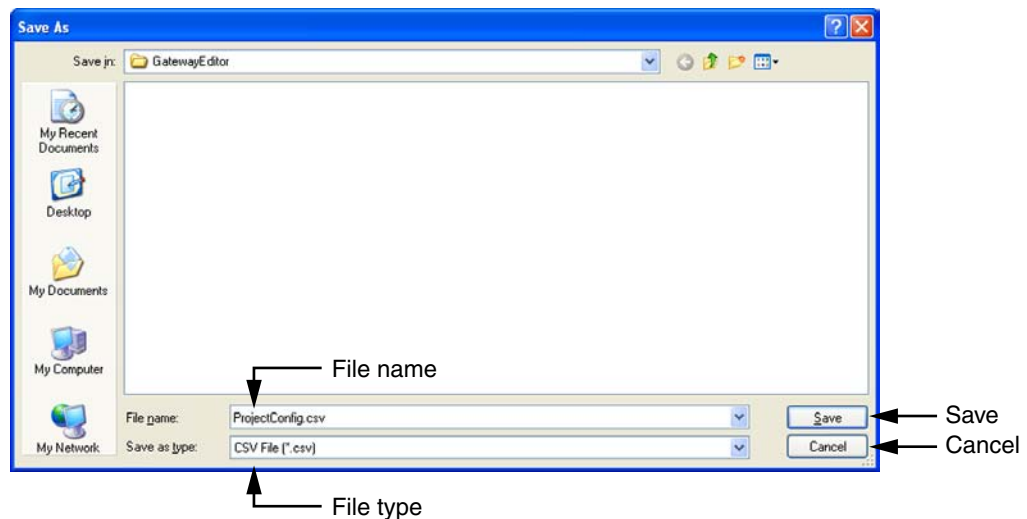

- (2) Open the folder to which you wish to save the project, and input the file name.
 (If you want to overwrite the project onto an existing file, select the file.)
- (3) Click the [Save] button.
 >> A CSV file is saved with the specified file name.

Note

The default initial folder when starting up for the first time is “My Documents \GatewayEditor\” In subsequent startups, the folder selected the previous time appears as the initial folder.

9 - 2 System Configuration

9-2-1 Module constitution

If you select a module to be connected to any channel of the CMC15G, you can set up various kinds of processes.

To display the Module Constitution screen, double-click Constitution in the project view or select [System Configuration] → [Constitution] from [Config] on the main menu.

■ Screen layout

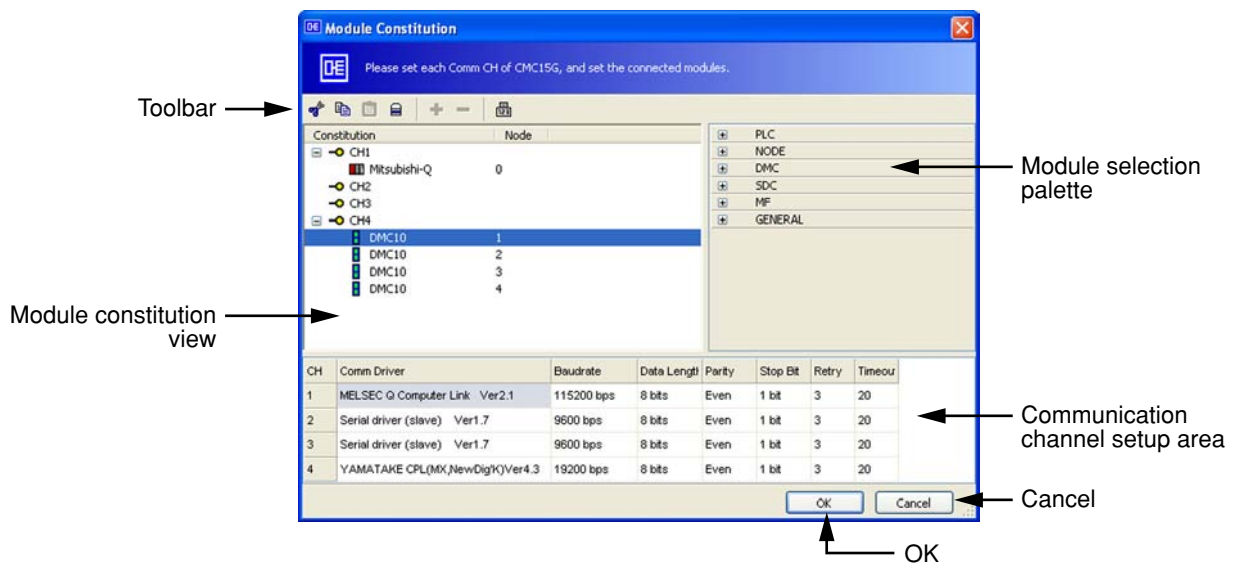

● Module selection palette

Modules you can connect to the CMC15G are displayed by type.

When clicking a desired type, the list of modules to be connected is displayed under the selected type. You can assign a module displayed in the list to the module constitution view through the mouse drag & drop operation.

● Module constitution view

Modules connected to the CMC15G are displayed hierarchically.

Constitution column: Displays the module constitution.

Node column: Displays the node address of the connected module.

Various operations are possible:

- Addition of new modules (up to 500) from the module selection palette
- Node address change for any connected module
- Module configuration editing (copy/paste/delete/move) in the module constitution view
- Selection of multiple items in the same hierarchy

● Communication channel setup area

This area displays the communication configuration of the communication channels (CH1 to CH4).

This configuration is common to the modules connected to the same communication channel.

● **Toolbar**

Clicking a button on the toolbar will execute the corresponding editing function in the module constitution view.

● **OK button / Cancel button**

Clicking the [OK] button will close the Module Constitution window with the configuration made effective.

On the contrary, clicking the [Cancel] button will close the Module Constitution window with the configuration made ineffective.

■ **Operating procedures**

- Procedures

- (1) Select a module you want to connect from the module selection palette and add it to the module constitution view.
- (2) Set up the communication channel assigned to the module.
- (3) If necessary, change the node address of the connected module.
- (4) Click the [OK] button.

>> The module selection palette in the main window is then changed.

● **Adding a connected module**

- Adding a module by drag & drop

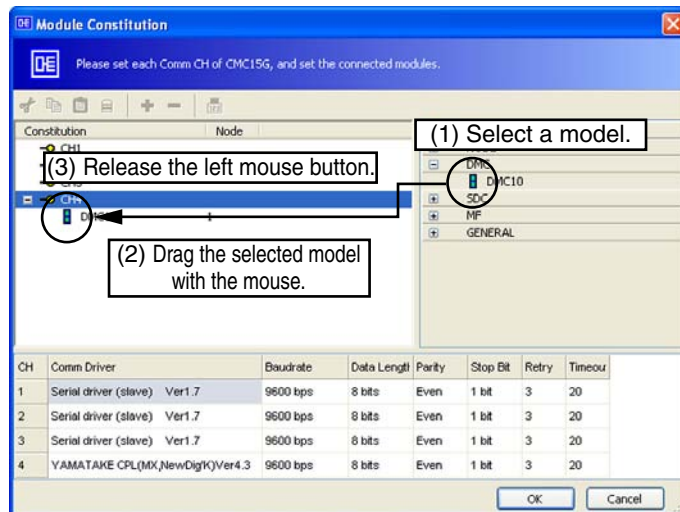

- (1) Display a module you want to connect on the module selection palette and select it.
- (2) Move the mouse cursor onto the module you want to connect on the module selection palette. Press and hold the left mouse button, and then move the mouse cursor into the module constitution view.
- (3) Move the mouse cursor to location to which you would like to connect in the module constitution view and release the left mouse button.

- Adding a module by double-clicking
 - (1) Select the place in the module constitution view where you want to connect a module.
 - (2) Double-click the module you want to connect on the module selection palette.

! Handling Precautions

- Up to 500 modules can be connected.
- When you connect a module to a communication channel, the communication driver is set up automatically.
If a module is already connected to a channel, any other module connected to that channel must use the same driver. A module that does not use the same driver cannot be connected.
- The SDU10 can be connected only as a slave station to the DMC10.
- When using the SDU10 in THROUGH mode (with node address "0"), do not add the SDU10 to the communication channel in the module constitution view, but rather add the DMC10.

● Communication channel configuration

Communication channels can be configured using the Communication channel setup area.

Communication driver

A communication driver is automatically set up when the module is connected. If no modules are connected to a channel, the serial slave station communication driver is used.

Band rate (bps)

Select either 600, 1200, 2400, 4800, 9600, 19200, 38400, 57600, or 115200. The initial value may vary depending on the type of connected module.

Data length

Select "7 bits" or "8 bits." The initial value is "8 bits."

Parity

Select "none", "even", or "odd." The initial value is "even."

Stop bit

Select "1 bit" or "2 bits." The initial value is "1 bit."

Retry

Input a value ranging from 0 to 15. The initial value is "3."

Time-out time (100 ms)

Input a value ranging from 1 to 255 (0.1 s to 25.5 s). The initial value is "20" (2 s).

● **Changing a node address**

- Procedures

(1) Select the connected module whose address you want to change in the module constitution view, right-click to display the pop-up menu and select [Change node address]. Or, select the module and click  on the toolbar.

>> The Node Address window will appear.

(2) Input a node address and click the [OK] button.

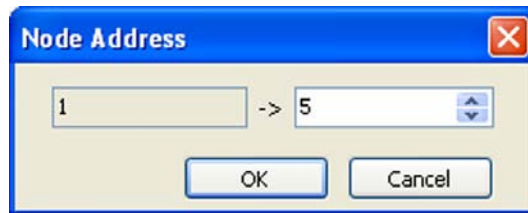

 **Handling Precautions**

You cannot specify a node address already in use.

The available node address range is “0” to “127.” You cannot select an address beyond this range.

 **Note**

If you construct a hierarchical structure using the CMC10B in the module constitution view, you can select multiple modules in the module constitution view only within the same hierarchy. You cannot select multiple modules across different hierarchies.

9-2-2 Option configuration

Option configuration is used to set up the CMC15G main unit.

To open the Option Configuration window, double-click [Option (O)] in the project view or select [System Config (S)] → [Option (O)] from [Config (C)] on the main menu.

■ General

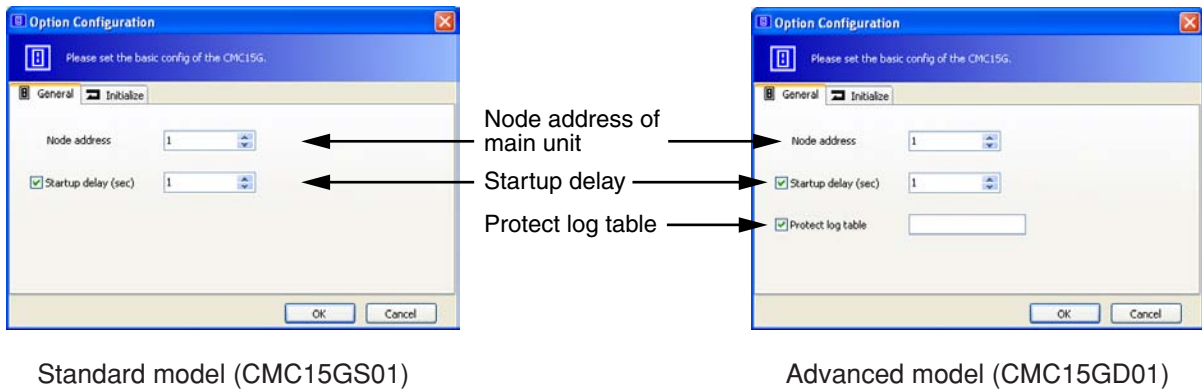

● Node address of main unit

Specifies a node address for the CMC15G main unit.

This node address is used when the CMC15G serves as a slave station and communicates with the host computer.

The available range of nodes is 1 to 126. The initial value is “1.”

● Startup delay

This setting is intended to delay startup of the CMC15G for a specified amount of time after the mode has been changed to RUN. If you wish to start CMC15G operation immediately after the mode is changed to RUN, do not check the check box. By default the check box is not checked.

To enable startup delay, check the check box and set a delay time in seconds. The settable range is 1 to 360 s. The initial value is “1.”

● Protect log table

This protect log table box is shown only when using the CMC15GD01 advanced model. This function protects recorded data collected by the CMC15G with a password.

If you check the [Protect log table] check box, you can input a password. By default the [Protect log table] check box is not checked.

Up to 10 alphanumeric characters can be input for the password.

Note

- If the password is set, you must input it in order to read or delete recorded data using the LogViewer.

Initialization

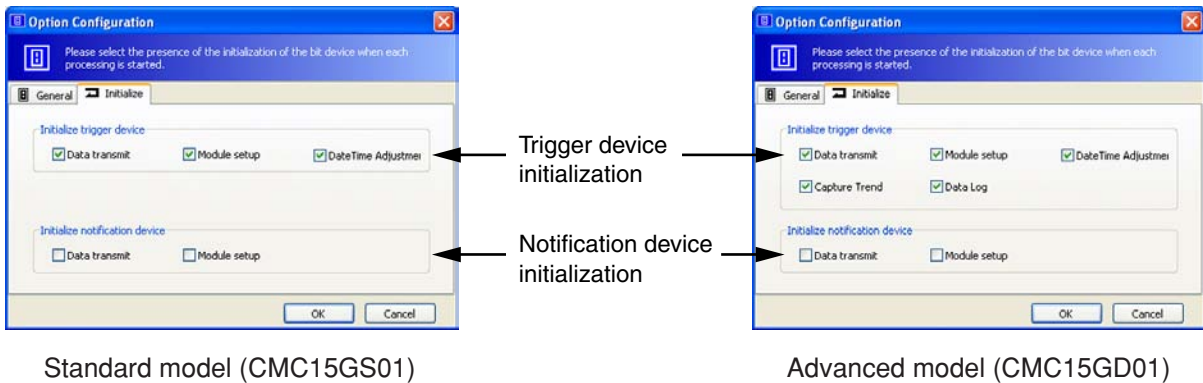

● Trigger device initialization

You can initialize a trigger device whose status has changed when starting up the process in the following functions:

- Data transmit (only when the trigger is activated)
- Module setup
- Date & time adjustment
- Captured trends function (CMC15GD01 advanced model only)
- Data log (CMC15GD01 advanced model only)

By default all check boxes are checked.

● Notification device initialization

You can initialize a notification device whose status has changed when starting up the process in the following functions:

- Data transmit (only when the trigger is activated)
- Module setup

By default no boxes are checked.

9 - 3 Basic Function Configuration

9-3-1 Data transmit

Data is transmitted from the connected module to other connected modules either periodically or when a change in the trigger device is detected.

■ Screen layout

Parameter	Value
Execute condition	Cyclic(Auto)
- Priority	Normal
Completion notification	Disable
- Notification device	---
Error notification	Disable
- Notification device	---
Effective change	Always effective
- Monitor device	---

No.	CH	Node	Address(Sender)	CH	Node	Address(Receiver)	Size	Notes
1	4	1	01004	1	0	D0000000	1word	CH1 PV value
2	4	1	01005	1	0	D0000001	1word	CH2 PV value
3	4	1	01006	1	0	D0000002	1word	CH3 PV value
4	4	1	01007	1	0	D0000003	1word	CH4 PV value

● Execute condition

Specifies conditions for starting the group process. Double-click the box in the Value column and select any of the following items from the drop-down list:

- Cyclic (Auto)
- Cyclic (Fixed)
- Trigger (OFF → ON)
- Trigger (ON → OFF)

The initial value is “Cyclic (Auto).”

Priority

This configuration box is shown when “Cyclic (Auto)” is selected in the [Execution condition] box.

The configuration box specifies the priority for the group process startup. Select either of the settings shown below from the drop-down list.

- Normal
- High

The initial value is “Normal.”

Cyclic (s)

This configuration box is shown when “Cyclic (Fixed)” is selected in the [Execution condition] box.

Specifies the cycle time (in seconds) for starting up the group process. The allowable range is 1 to 7200 s.

The initial value is “10.”

Trigger device

This setting specifies a trigger device for starting the group process.
The initial value is blank.

● Completion notification

Specifies whether or not to notify the host station upon completion of the group process. The configuration box specifies the priority for the group process startup. Select either of the settings shown below from the drop-down list.

- Disable
- Enable

The initial value is “Disable.”

Notification device

A notification device can be set up if “Enable” is selected in the [Completion notification] box.

This setting specifies the device that is notified on the host station.

The initial value is blank.

● Error notification

Specifies whether or not to notify the host station if an error occurs in the group process. The configuration box specifies the priority for the group process startup. Select either of the settings shown below from the drop-down list.

- Disable
- Enable

The initial value is “Disable.”

Notification device

A notification device can be set up if “Enable” is selected in the [Completion notification] box.

This setting specifies the device that is notified on the host station. The initial value is blank.

● Effective change

Specifies whether, after the group process is triggered, it automatically runs, or whether its execution is dependent upon the status of a monitor device. The configuration box specifies the priority for the group process startup. Select either of the settings shown below from the drop-down list.

- Always effective
- Effective at bit status ON
- Effective at bit status OFF

The initial value is “Always effective.”

Monitor device

If the [enabled-disabled setting] is “Effective at bit status ON” or “Effective at bit status OFF,” a monitor device must be designated. This is the bit on the host station that will determine whether the process is enabled or disabled.

The initial value is blank.

- **Sender setup**

Specifies a sender device. The data read from this device is written to the receiver device.

Select a device on the connected module.

The initial value is blank.

For sequential execution, right-click the line No. you want to synchronize and select [Insert sync line] or input “SYNC” (uppercase characters) in the CH cell at the left end of the line.

You can specify data to be transmitted directly in the data transmission. The input range may vary depending on the data format and size. The settable ranges are as follows:

Signed decimal values (with uppercase character “K” before the numeric value):

- 1 word: K - 32768 to K 32767
- 2 words: K - 2147483648 to K2147483647

Hexadecimal values (with character “#” before the numeric value)

- 1 word: #0000 to #FFFF
- 2 words: #00000000 to #FFFFFFFF

To directly specify data, leave the CH and Node fields blank.

- **Receiver setup**

Specifies a receiver device. The data read from the sender is written to this device.

Select a device on the connected module.

The initial value is blank.

- **Size**

Specifies the number of words of data to transmit at one time.

In the case of modules supporting continuous read and write using the communication command, the size is determined by the same communication command.

Select either of the items shown below from the drop-down list.

- 1 word
- 2 words

The initial value is “1 word.”

● **Notes**

The names of devices registered in the address list of the devices set in the sender setup and receiver setup are displayed as reference information.

 **Handling Precautions**

- If multiple groups use the same trigger, do not check the check boxes in the “Initialize trigger device” area. If initialization is enabled, groups may not detect a change in the trigger device, depending on the trigger initialization timing.
- If you use a special contact (SM900.0 to SM999.F) as a trigger device, do not check the check boxes in the “Initialize trigger device” area. If initialization is enabled, trigger device initialization will fail since writing is not possible.

9-3-2 Module setup

If a change in the trigger device is detected, the initial settings (fixed data) are transmitted to the connected modules.

■ Screen layout

Parameter	Value
Execute condition	Trigger(OFF->ON)
- Trigger device	1:0:M0000100
Completion notification	Disable
- Notification device	---
Error notification	Disable
- Notification device	---
Effective change	Always effective
- Monitor device	---

No.	CH	Node	Address	Data format	Size	Data	Notes
1	4	1	01032	Singed decimal	1word	0	CH1 RUN/READY mode
2	4	1	01033	Singed decimal	1word	0	CH2 RUN/READY mode
3	4	1	01034	Singed decimal	1word	0	CH3 RUN/READY mode
4	4	1	01035	Singed decimal	1word	0	CH4 RUN/READY mode

● Execute condition

Specifies conditions for starting the group process. Select any of the following items from the drop-down list:

- Trigger (OFF → ON)
- Trigger (ON → OFF)

The initial value is “Trigger (OFF → ON).”

Trigger device

This setting specifies a trigger device for starting the group process. The initial value is blank.

● Completion notification

Specifies whether or not to notify the host station upon completion of the group process. The configuration box specifies the priority for the group process startup. Select either of the settings shown below from the drop-down list.

- Disable
- Enable

The initial value is “Disable.”

Notification device

A notification device can be set up if “Enable” is selected in the [Completion notification] box.

This setting specifies the device that is notified on the host station.

The initial value is blank.

● **Error notification**

Specifies whether or not to notify the host station if an error occurs in the group process. The configuration box specifies the priority for the group process startup. Select either of the settings shown below from the drop-down list.

- Disable
- Enable

The initial value is “Disable.”

Notification device

A notification device can be set up if “Enable” is selected in the [Completion notification] box.

This setting specifies the device that is notified on the host station. The initial value is blank.

● **Effective change**

Specifies whether, after the group process is triggered, it automatically runs, or whether its execution is dependent upon the status of a monitor device. The configuration box specifies the priority for the group process startup. Select either of the settings shown below from the drop-down list.

- Always effective
- Effective at bit status ON
- Effective at bit status OFF

The initial value is “Always effective.”

Monitor device

If the [Effective change] is “Effective at bit status ON” or “Effective at bit status OFF,” a monitor device must be designated. This is the bit on the host station that will determine whether the process is enabled or disabled.

The initial value is blank.

● **Write destination setup**

Specifies a device at the write destination.

Enter a device on the connected module.

The initial value is blank.

For sequential execution, right-click the line No. you want to synchronize and select [Insert sync line] or input “SYNC” (uppercase characters) in the CH cell at the left end of the line.

● **Data format**

Determines the type of data transmitted.

Select any of the following items from the drop-down list:

- Signed decimal
- Unsigned decimal
- BCD
- HEX
- Floating-point

The initial value is “Signed decimal.”

- **Size**

Specifies the size of the transmitted data. Select either of the choices below from the drop-down list. (If “Floating-point” is selected in the Data format field, you can select only “2 words.”)

- 1 word
- 2 words

The initial value is “1 word.” (If “Floating-point” is selected in the data format field, “2 words” is the only selection available.)

- **Data**

Specify the type of data to be transmitted in module setup. The input range may vary depending on the data format and size. The settable ranges are:

Signed decimal values

- 1 word: – 32768 to +32767
- 2 words: – 2147483648 to +2147483647

Unsigned decimal

- 1 word: 0 to 65535
- 2 words: 0 to 4294967295

Hexadecimal values

- 1 word: 0000 to FFFF
- 2 words: 00000000 to FFFFFFFF

BCD

- 1 word: 0000 to 9999
- 2 words: 00000000 to 99999999

Floating-point

–3.402823E+38 to –1.175494E-38, 0, +1.175494E-38 to +3.402823E+38

The initial value is “0.”

- **Notes**

The names of devices registered in the address list of the devices set in the write destination setup are displayed as reference information.

 **Handling Precautions**

- If multiple groups use the same trigger, do not check the check boxes in the “Initialize trigger device” area. If initialization is enabled, groups may not detect a change in the trigger device, depending on the trigger initialization timing.
- If you use a special contact (SM900.0 to SM999.F) as a trigger device, do not check the check boxes in the “Initialize trigger device” area. If initialization is enabled, trigger device initialization will fail since writing is not possible.

9-3-3 Internal event function

This function monitors the bit or numeric value device on the connected module to determine whether to turn ON/OFF the corresponding bit inside the CMC15G.

■ Screen layout

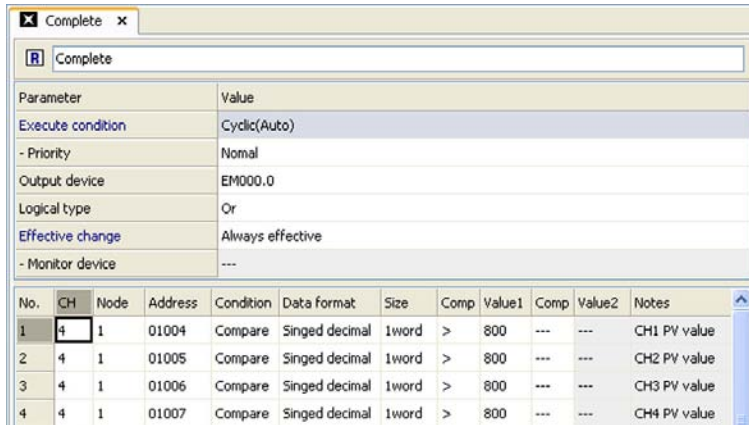

● Execute condition

Specifies conditions for starting the group process. Select any of the following items from the drop-down list:

- Cyclic (Auto)
- Cyclic (Fixed)

The initial value is “Cyclic (Auto).”

Priority

This configuration box is shown when “Cyclic (Auto)” is selected in the [Execution condition] box.

The configuration box specifies the priority for the group process startup. Select either of the settings shown below from the drop-down list.

- Normal
- High

The initial value is “Normal.”

Cyclic (s)

This configuration box is shown when “Cyclic (Fixed)” is selected in the [Execution condition] box.

Specifies the cycle time (in seconds) for starting up the group process. The allowable range is 1 to 7200 s.

The initial value is “10.”

● Output device

Specifies the device to which the results of the internal event function are output. Select any of the following from the drop-down list:

EM000.0 to EM001.3

The initial value is “EM000.0.”

● Logical type

Specifies the type of logical connection to use when relating the device status at each comparison source.

Select either setting shown below from the drop-down list.

- Or
- And

The initial value is “Or.”

● Effective change

Specifies whether, after the group process is triggered, it automatically runs, or whether its execution is dependent upon the status of a monitor device. The configuration box specifies the priority for the group process startup. Select either of the settings shown below from the drop-down list.

- Always effective
- Effective at bit status ON
- Effective at bit status OFF

The initial value is “Always effective.”

Monitor device

If the [enabled-disabled setting] is “Effective at bit status ON” or “Effective at bit status OFF,” a monitor device must be designated. This is the bit on the host station that will determine whether the process is enabled or disabled.

The initial value is blank.

● Comparison source setup

Specifies comparison source devices.

Select a device on the connected module.

The initial value is blank.

● **Condition**

Specifies necessary conditions for judging the status of devices. Select any of the following items from the drop-down list:

- Bit ON
- Bit OFF
- Compare

The initial value is “Bit ON.”



Note

If a word device is specified as the source to read, any value other than “0” is handled as “Bit ON.”

● **Data format**

The Data format column is valid when “Compare” is set in the condition field.

It specifies the data type. Determines the type of data transmitted.

Select any of the following items from the drop-down list:

- Signed decimal
- Unsigned decimal
- BCD
- HEX
- Floating-point

The initial value is “Signed decimal.”

● **Size**

This Size column is valid when “Compare” is selected in the condition field. It specifies the amount of data to read. Select either of the choices below from the drop-down list. (If “Floating-point” is selected in the Data format field, you can select only “2 words.”)

- 1 word
- 2 words

The initial value is “1 word.” (If “Floating-point” is selected in the Data format field, “2 words” is the only selection available.)

● **Compare 1**

The Comp 1 column is valid when “Compare” is selected in the condition field. It specifies the type of comparison to use for numeric values. It specifies the amount of data to read. Select either of the choices below from the drop-down list.

- > : The value of comparison source device is larger than value 1.
- >= : The value of comparison source device is value 1 or more.
- < : The value of comparison source device is smaller than value 1.
- <= : The value of comparison source device is value 1 or less.
- == : The value of comparison source device is corresponding to value 1.
- != : The value of comparison source device is not corresponding to value 1.

The initial value is “>.”

- **Value 1**

Specifies a numeric value to use for comparison.

The input range may vary depending on the data format and size.

The settable ranges are as follows:

Signed decimal values

- 1 word: - 32768 to +32767
- 2 words: - 2147483648 to +2147483647

Unsigned decimal

- 1 word: 0 to 65535
- 2 words: 0 to 4294967295

BCD

- 1 word: 0000 to 9999
- 2 words: 00000000 to 99999999

Hexadecimal values

- 1 word: 0000 to FFFF
- 2 words: 00000000 to FFFFFFFF

Floating-point

-3.402823E+38 to -1.175494E-38, 0, +1.175494E-38 to +3.402823E+38

The initial value is "0."

- **Compare 2**

The comp 2 column is valid if the following conditions are met:

- "Compare" is selected in the condition field.
- A symbol other than ">=" and ">" is selected in the comp 1 field.

Comp 2 specifies the type if a second numeric value is to be compared. When the conditions in the comp 1 and comp 2 fields are satisfied, the contact of the output device is turned ON. It specifies the amount of data to read. Select either of the choices below from the drop-down list.

- - - - : a second numeric value is not to be compared.
- <= : The value of comparison source device is value 2 or less.
- < : The value of comparison source device is smaller than value 2.

The initial value is "- - -."

● **Value 2**

The value 2 column is valid when a symbol other than “- - -”, is set in the comp 2 column.

Value 2 specifies the numeric value used for the comparison.

The input range may vary depending on the data format and size.

The settable ranges are as follows:

Signed decimal values

- 1 word: - 32768 to +32767
- 2 words: - 2147483648 to +2147483647

Unsigned decimal

- 1 word: 0 to 65535
- 2 words: 0 to 4294967295

BCD

- 1 word: 0000 to 9999
- 2 words: 00000000 to 99999999

Hexadecimal values

- 1 word: 0000 to FFFF
- 2 words: 00000000 to FFFFFFFF

Floating-point

-3.402823E+38 to -1.175494E-38, 0, +1.175494E-38 to +3.402823E+38

The initial value is “0.”

● **Notes**

The names of devices registered in the address list of the devices set in the read-out source setup are displayed as reference information.

9 - 4 Logging Function Configuration

9-4-1 Trend

Trend functions can be set up only on the CMC15GD01 advanced model. Trend functions record numeric data from the host station and slave station in the internal memory of the CMC15G at constant intervals. There is a continuous trend function and a captured trends function.

■ Screen layout

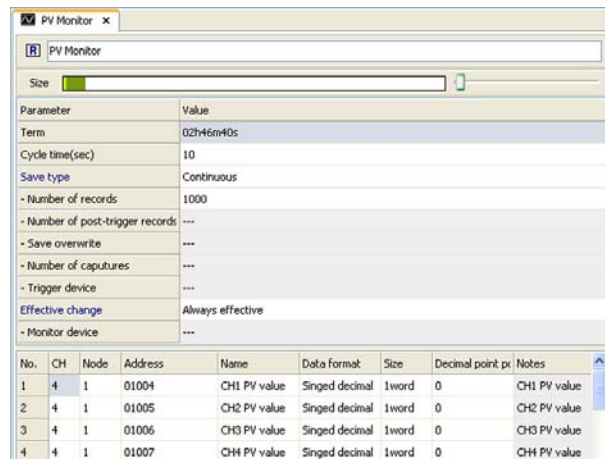

● Size setup

You can change the size of the backup memory used for the set group by moving the track bar.

For a continuous trend, adjust the number of records.

For the captured trends function, set the total number of pre-trigger records and post-trigger records. The change ratio is a percentage of the value input in the [Number of pre-trigger records] or [Number of post-trigger records] box.

📖 Note

- The size may be affected by the size of the backup memory used by the main unit. The high limit may vary depending on the settings for trend, data log, and event log.

Set the size while carefully checking the size setup bar graph.

● Term

The time in which the continuous trend save process is completed or the time after which the trend data is saved as one capture is displayed. This time is automatically calculated from the cycle time and the number of records.

● Cycle time (sec)

Specifies the cycle time (in seconds) for starting up the group process. The allowable range is 1 to 7200 s.

The initial value is “10.”

● **Save type**

The time in which the continuous trend save process is completed or the time after which the trend data is saved as one capture is displayed. This time is automatically calculated from the cycle time and the number of records.

The Save type setting specifies the method of saving collected trend data. Select from the following items on the drop-down list. Use this setting to switch between continuous trend and captured trends functions.

- Continuous
- Trigger capture (OFF->ON)
- Trigger capture (ON->OFF)

The initial value is “Continuous.”

Number of records

Available only if “Continuous” is selected in the [Save type] box.

Specifies the number of data records to be saved.

Input a numeric value ranging from “1” to “110000.”

The initial value is “1000.”

Number of pre-trigger records

Available only if “Capture” is selected in the [Save type] box.

Specifies the number of data records to be saved before the trigger occurs.

Input a numeric value ranging from “1” to “110000.”

The initial value is “1000.”

Number of post-trigger records

Available only if “Capture” is selected in the [Save type] box.

Specifies the number of data records to be saved after the trigger occurs.

Input a numeric value ranging from “1” to “110000.”

The initial value is “1000.”

Save overwrite

Available only if “Capture” is selected in the [Save type] box.

This setting is not available for continuous trends, since the data in that case is always saved in overwrite mode. Select whether or not to overwrite past capture data if the memory for captures is full.

Select either of the settings shown below from the drop-down list.

- Disable
- Enable

The initial value is “Disable.”

Number of captures

Available only if “Capture” is selected in the [Save type] box.

Specifies how many triggers are saved.

Input a numeric value ranging from “1” to “100.”

The initial value is “1.”

Trigger device

Available only if “Capture” is selected in the [Save type] box.

Specifies a device on the host station that judges the trigger.

The initial value is blank.

● Effective change

You can specify whether, after a group process is triggered, it automatically runs, or whether its execution is dependent upon the status of a monitor device. The configuration box specifies the priority for the group process startup. Select either of the settings shown below from the drop-down list.

- Always effective
- Effective at bit status ON
- Effective at bit status OFF

The initial value is “Always effective.”

Monitor device

If the [Effective change] is “Effective at bit status ON” or “Effective at bit status OFF,” a monitor device must be designated. This is the bit on the host station that will determine whether the process is enabled or disabled.

The initial value is blank.

● Name

Specifies a name for the collected trend data.

Up to 16 characters can be set.

The initial value is blank.

● Read source setup

Specifies a read source device.

Select a device on the connected module.

The initial value is blank.

● **Data format**

Specifies the type of data to collect.

Select any of the following items from the drop-down list:

- Signed decimal
- Unsigned decimal
- BCD
- HEX
- Floating-point

The initial value is “Signed decimal.”

● **Size**

Specifies the size of data to collect.

Select either of the choices below from the drop-down list. (If “Floating-point” is selected in the Data format field, you can select only “2 words.”)

- 1 word
- 2 words

The initial value is “1 word.”

● **Decimal point position**

Specifies the decimal point position for the collected data.

You can set the decimal point position only if “Signed decimal”, “Unsigned decimal”, or “BCD” is set for the data format.

The initial value is “0” (without the decimal point).

The range you can input may vary depending on the data format and size.

Signed decimal values

- 1 word: 0 to 5
- 2 words: 0 to 10

Unsigned decimal

- 1 word: 0 to 5
- 2 words: 0 to 10

BCD

- 1 word: 0 to 4
- 2 words: 0 to 8



Note

- If the decimal point position exceeds the range when the data format or size is changed, an error message is displayed.

9-4-2 Data log

Data log functions can be set up only on the CMC15GD01 advanced model. This function saves information from the host station and slave station to the internal memory of the CMC15G if a change in the specified bit is detected.

■ Screen layout

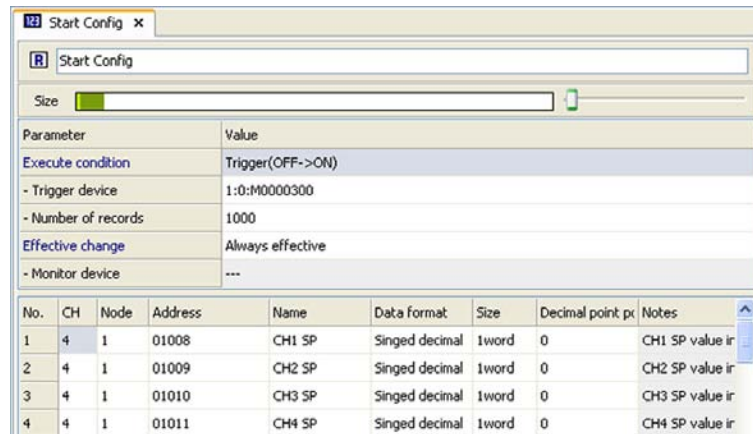

● Size setup

You can change the size of the backup memory used for the set group by moving the track bar.

For a continuous trend, adjust the number of records.

● Execution condition

Specifies conditions necessary to start up the group process. Select either of the following items from the drop-down list:

- Trigger (OFF->ON)
- Trigger (ON->OFF)

The initial value is “Trigger (OFF->ON).”

Trigger device

Specifies a trigger device for starting the group processing. The initial value is blank.

Number of records

Specifies the number of data records to save.

Input a numeric value ranging from 1 to 110000. The initial value is “1000.”

Note

- The size may be affected by the size of the backup memory used by the main unit. The high limit may vary depending on the settings for trend, data log, and event log.

Set the size while carefully checking the size setup bar graph.

● **Effective change**

You can specify whether, after a group process is triggered, it automatically runs, or whether its execution is dependent upon the status of a monitor device. The configuration box specifies the priority for the group process startup. Select either of the settings shown below from the drop-down list.

- Always effective
- Effective at bit status ON
- Effective at bit status OFF

The initial value is “Always effective.”

Monitor device

If the [Effective change] is “Effective at bit status ON” or “Effective at bit status OFF,” a monitor device must be designated. This is the bit on the host station that will determine whether the process is enabled or disabled.

The initial value is blank.

● **Name**

Specifies a name for the collected data log.

Up to 16 characters can be set.

The initial value is blank.

● **Read source setup**

Specifies a read source device.

Select a device on the connected module.

The initial value is blank.

● **Data format**

Specifies the type of data to collect.

Select any of the following items from the drop-down list:

- Signed decimal
- Unsigned decimal
- BCD
- HEX
- Floating-point

The initial value is “Signed decimal.”

- **Size**

Specifies the size of data to collect.

Select either of the choices below from the drop-down list. (If “Floating-point” is selected in the Data format field, you can select only “2 words.”)

- 1 word
- 2 words

The initial value is “1 word.”

- **Decimal point position**

Specifies the decimal point position for the collected data.

You can set the decimal point position only if “Signed decimal”, “Unsigned decimal”, or “BCD” is set for the data format.

The initial value is “0” (without the decimal point).

The range you can input may vary depending on the data format and size.

Signed decimal values

- 1 word: 0 to 5
- 2 words: 0 to 10

Unsigned decimal

- 1 word: 0 to 5
- 2 words: 0 to 10

BCD

- 1 word: 0 to 4
- 2 words: 0 to 8



Note

- If the decimal point position exceeds the range when the data format or size is changed, an error message is displayed.

9-4-3 Event log

Event log functions can be set up only on the CMC15GD01 advanced model. This function saves the event, type, and time to the internal memory of the CMC15G if an event occurs in a connected module.

■ Screen layout

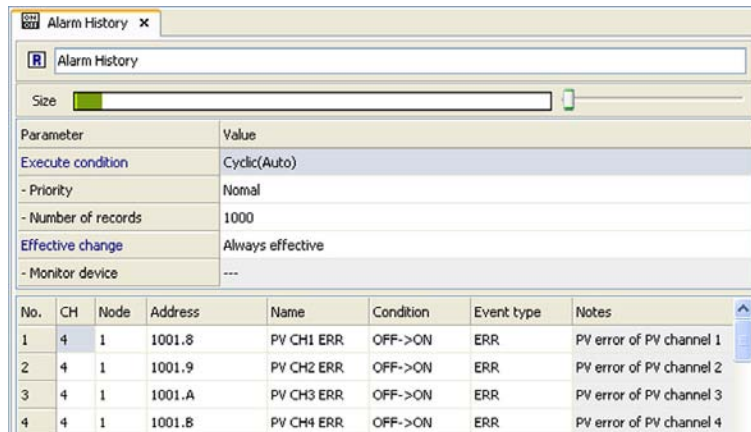

● Size setup

You can change the size of the backup memory used for the set group by moving the track bar.

For a continuous trend, adjust the number of records.

● Execution condition

Specifies conditions necessary to start up the group process. Select either of the following items from the drop-down list:

- Cyclic (Auto)
- Cyclic (Fixed)

The initial value is “Cyclic (Auto).”

Priority

This configuration box is shown when “Cyclic (Auto)” is selected in the [Execution condition] box.

The configuration box specifies the priority for the group process startup. Select either of the settings shown below from the drop-down list.

- Normal
- High

The initial value is “Normal.”

Cyclic (s)

This configuration box is shown when “Cyclic (Fixed)” is selected in the [Execution condition] box.

Specifies the cycle time (in seconds) for starting up the group process. The allowable range is 1 to 7200 s.

The initial value is “10.”

Number of records

Specifies the number of data records to save.

Input a numeric value ranging from 1 to 110000. The initial value is “1000.”

Note

- The size may be affected by the size of the backup memory used by the main unit. The high limit may vary depending on the settings for trend, data log, and event log.

Set the size while carefully checking the size setup bar graph.

● Effective change

You can specify whether, after a group process is triggered, it automatically runs, or whether its execution is dependent upon the status of a monitor device. The configuration box specifies the priority for the group process startup. Select either of the settings shown below from the drop-down list.

- Always effective
- Effective at bit status ON
- Effective at bit status OFF

The initial value is “Always effective.”

Monitor device

If the [Effective change] is “Effective at bit status ON” or “Effective at bit status OFF,” a monitor device must be designated. This is the bit on the host station that will determine whether the process is enabled or disabled.

The initial value is blank.

● Name

Specifies a name for the collected event log.

Up to 16 characters can be set.

The initial value is blank.

● Read source setup

Specifies a read source device.

Select a device on the connected module.

The initial value is blank.

● **Condition**

Specifies a condition for event detection.

Select either of the settings shown below from the drop-down list.

- OFF->ON
- ON->OFF
- OFF<->ON

The initial value is “OFF->ON.”

● **Event type**

Specifies an event type.

Select either of the settings shown below from the drop-down list. When reading the data using the LogViewer, you can filter the data by event type.

- INFO (information)
- WARN (warning)
- ERR (error)

The initial value is “INFO.”

9 - 5 Extended Function Configuration

9-5-1 Status notification

■ Screen layout

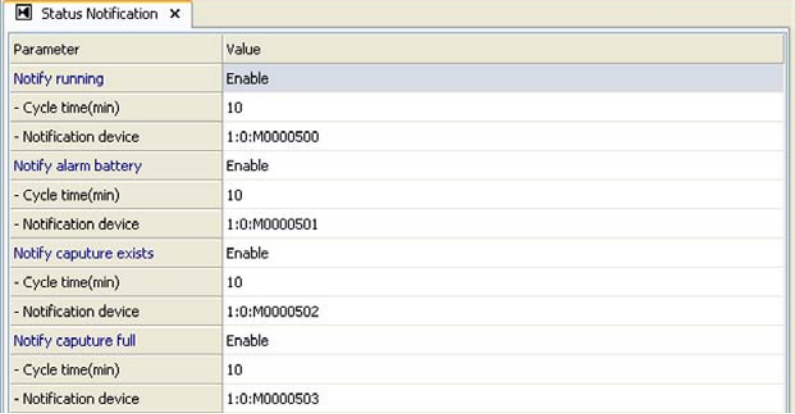

Parameter	Value
Notify running	Enable
- Cycle time(min)	10
- Notification device	1:0:M0000500
Notify alarm battery	Enable
- Cycle time(min)	10
- Notification device	1:0:M0000501
Notify capture exists	Enable
- Cycle time(min)	10
- Notification device	1:0:M0000502
Notify capture full	Enable
- Cycle time(min)	10
- Notification device	1:0:M0000503

This function sends a notice to the host station if the status of the CMC15G is one of the following:

- Notify running
- Notify alarm battery
- Notify capture exists
- Notify capture full

● Effective change

Specifies whether or not the notification function is utilized. Select either of the settings shown below from the drop-down list.

- Disable
- Enable

The initial value is “Disable.”

● Cyclic (min)

Sets the cycle time (in minutes) for starting the group process.

The setting range is 1 to 120 minutes.

The initial value is “10.”

● Notification device

Specifies the device that is notified on the host station.

The initial value is blank.

9-5-2 Communication error notification

■ Screen layout

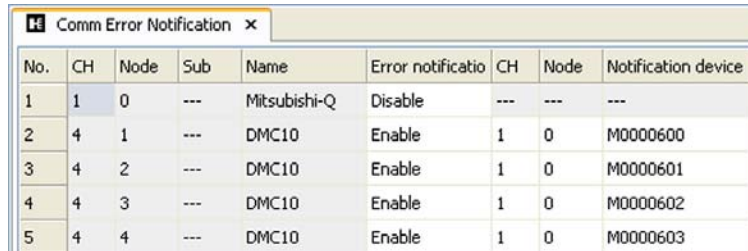

No.	CH	Node	Sub	Name	Error notificatio	CH	Node	Notification device
1	1	0	---	Mitsubishi-Q	Disable	---	---	---
2	4	1	---	DMC10	Enable	1	0	M0000600
3	4	2	---	DMC10	Enable	1	0	M0000601
4	4	3	---	DMC10	Enable	1	0	M0000602
5	4	4	---	DMC10	Enable	1	0	M0000603

If an error occurs during communication with a module connected to the CMC15G, this function notifies the host station of the error.

● Module information

Shows the CH (channel), Node (node address), Sub (sub-address), and module name.

● Error notification

Specifies whether or not notification of the host station is enabled. Select either of the settings shown below from the drop-down list.

- Disable
- Enable

The initial value is “Disable.”

● Notification device

Available only if “Enable” is selected in the Error notification field.

This setting specifies the host station device that is notified.

The initial value is blank.

9-5-3 Date and time adjustment

■ Screen layout

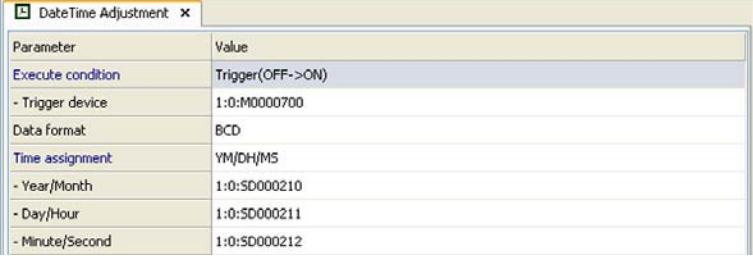

Parameter	Value
Execute condition	Trigger(OFF->ON)
- Trigger device	1:0:M0000700
Data format	BCD
Time assignment	YM/DH/MS
- Year/Month	1:0:SD000210
- Day/Hour	1:0:SD000211
- Minute/Second	1:0:SD000212

This function is changes the time on the CMC15G to the time specified by the host station.

● Execute condition

Specifies the conditions for executing date and time adjustment. Select either of the settings shown below from the drop-down list.

- Disable
- Trigger (OFF → ON)
- Trigger (ON → OFF)

The initial value is “Disable.”

● Trigger device

Displayed if trigger (OFF → ON) or trigger (ON → OFF) is selected in the [Execution condition] box.

Specifies the device on the host station that is used as a trigger for date and time adjustment.

The initial value is blank.

● Data format

Available if “Trigger (OFF → ON)” or “Trigger (ON → OFF)” is selected in the [Execution condition] box.

The data format setting specifies the format to use for the date and time data from the host station device. Select any of the following items from the drop-down list:

- Unsigned decimal
- BCD

The initial value is “BCD.”

- **Time assignment**

Displayed if trigger (OFF → ON) or trigger (ON → OFF) is selected in the [Execution condition] box. Specifies whether year, month, day, hour, minute, and second data set for host station devices is expressed in the upper and lower bytes of a single device, or is expressed in individual devices. Select either of the settings shown below from the drop-down list.

- YM / DH / MS
- Y / M / D / H / M / S

The initial value is “YM / DH / MS.”

- **Date and time**

Displayed if trigger (OFF → ON) or trigger (ON → OFF) is selected in the [Execution condition] box. Sets one word data of each of the following items for devices, for which the date and time of the host station are set:

- YM / DH / MS
 - Year/Month (Upper byte: year. Lower byte: month)
 - Day/Hour (Upper byte: day. Lower byte: hour)
 - Minute/Second (Upper byte: minute. Lower byte: second)
- Y / M / D / H / M / S
 - Year
 - Month
 - Day
 - Hour
 - Minute
 - Second

The initial value is blank.

 **Note**

The following describes the special registers for Mitsubishi Electric's PLC clock data:

QnA, Q (Q mode) : SD210 (Y / M), SD211 (D / H), SD212 (M / S)

A, Q (A mode) : D9025 (Y / M), D9026 (D / H), D9027 (M / S)

FX : D8018 (Y), D8017 (M), D8016 (D), D8015 (H), D8014 (M), D8013 (S)

Chapter 10 CONNECTING TO THE CMC15G WITH GATEWAYEDITOR

10 - 1 Connections

There are two ways to connect GatewayEditor to the CMC15G.

- USB mini-B connector
- Loader jack

Handling Precautions

- Never attempt to use the USB mini-B and loader jack at the same time. Doing so may cause a malfunction.

■ USB connection

Prior to using the USB connector, it is necessary to install the special device drivers on the personal computer. Installation of the drivers can be done using "setup.exe" on the included GatewayEditor Setup CD-ROM.

To connect with the USB connector, select [Tool] → [Environment...] and choose "USB."

Handling Precautions

- Do not connect two or more CMC15G units to one personal computer using USB connectors. Doing so may cause the communication to fail.

Upon first connecting the PC and CMC15G with a USB connection, the [Found New Hardware Wizard] window will appear.

■ Loader jack connection

Connect the Smart Loader Package for the temperature controller using the special cable supplied with the GatewayEditor. However, transmission speed is limited when connecting through the loader jack. Use of the USB connection is recommended for high-speed communication.

● For Windows XP

- (1) When using Windows XP which has been updated with Service Pack 2, the message "Can Windows connect to Windows Update to search for software?" will appear. This driver search will take a long time. Check [No, not this time] and click the [Next >] button.



 **Note**

If the above window is not shown even when using Windows XP with Service Pack 2, it will be necessary to wait a long time every time while the computer connects to Windows Update. To avoid this, do the following:

- (i) Select [Control Panel] → [Performance and Maintenance] → [System] to open the [System Property] window.
- (ii) Select the [Hardware] tab and click the [Windows Update] button to open the [Connect to Windows Update] window.
- (iii) Check on [Ask me to search Windows Update every time I connect a new device] and click the [OK] button.



- (2) The message "What do you want the wizard to do?" will appear. Check [Install the software automatically (Recommended)] and then click the [Next >] button.

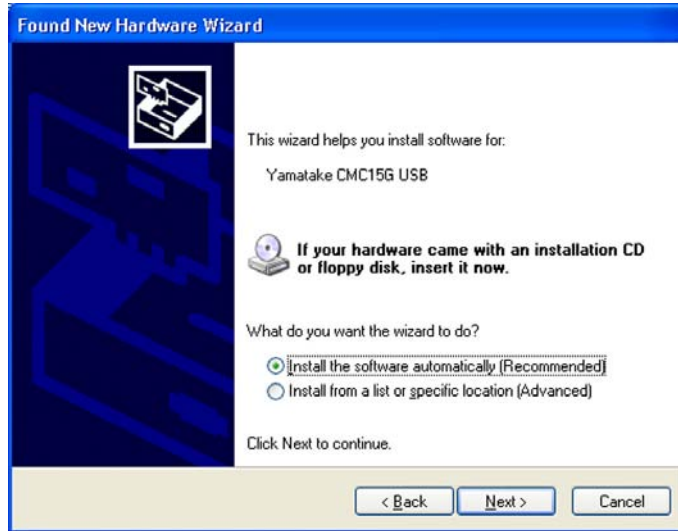

>>Software installation begins.

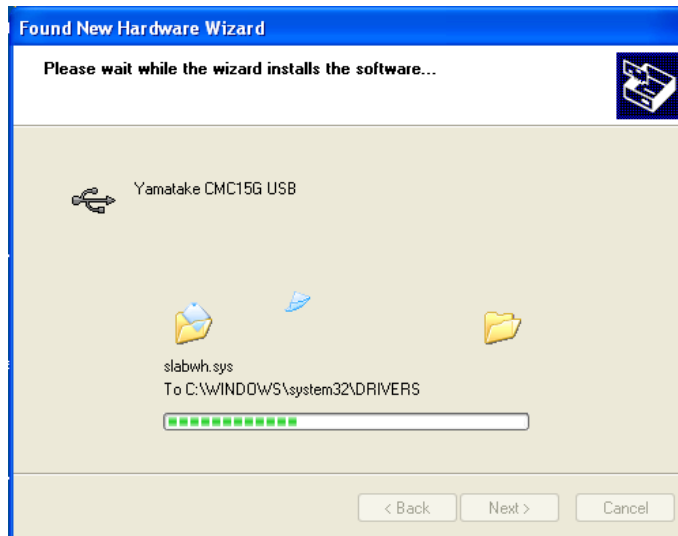

- (3) As the USB drivers are installed, two screens may appear.



Click the [Continue Anyway] button.

>>When Yamatake CMC15G USB drivers have been installed completely, the following window will appear:



! Handling Precautions

- If the installation is not completed successfully,  Incomplete installation (on page 10-5).

(4) When the completion screen appears, click the [Finish] button.

(5) Subsequently, install Yamatake CMC15G USB COM Port drivers in the same manner as described above.



(6) When the completion screen appears, click the [Finish] button.

- (7) When all steps have been completed successfully, the message "Your new hardware is installed and ready to use" appears in the lower right of the screen.

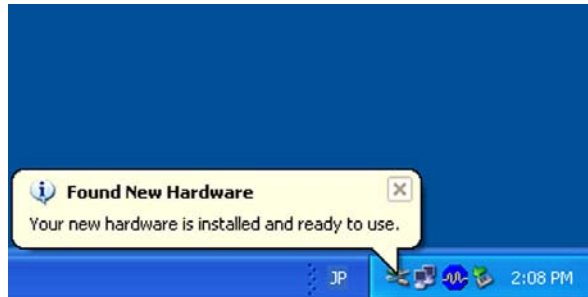

- Incomplete installation

If the message "What do you want the wizard to do?" appears as described in step (2), check on [Install from a list or specific location (Advanced)], and then click the [Next >] button.

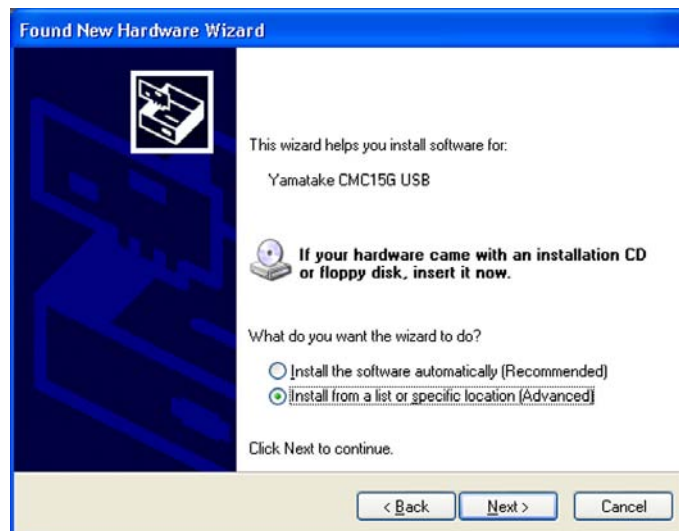

Click [Search for the best driver in these locations], and then select [Include this location in the search:].

Click the [Browse] button to select a folder in the SLP installation directory (the default directory is "C:\Program Files\SLP").

For Yamatake CMC15G USB drivers, select "SLPG15\usb\usb_vcp2." For Yamatake CMC15G USB COM port drivers, select "SLPG15\usb\usb_vcp1."

Then click the [Next >] button.

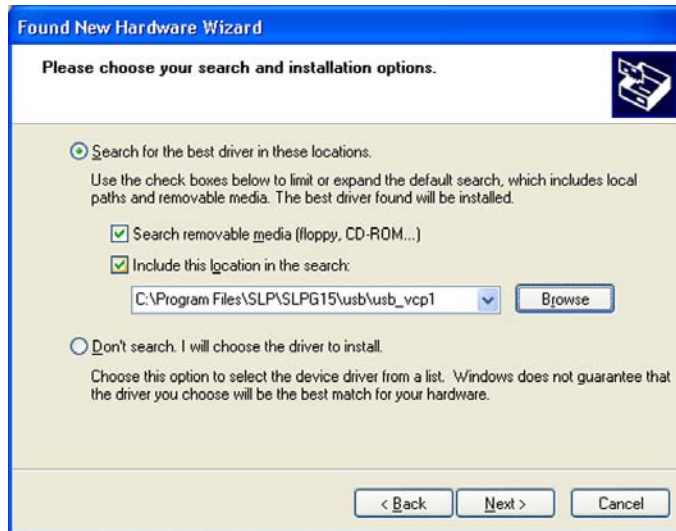

Subsequently, skip to step (4).

● For Windows 2000

When connecting the CMC15G through the USB port for the first time, the message below will appear and the installation will begin automatically.

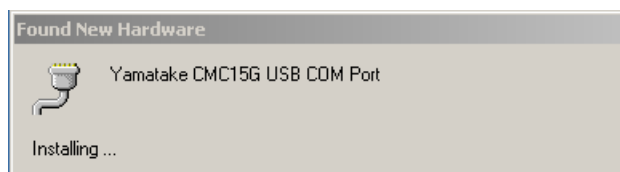
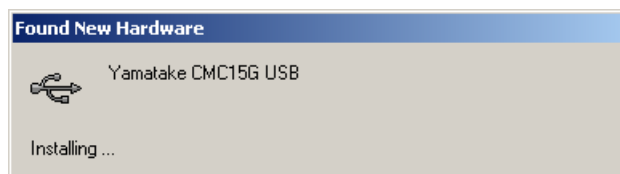

When both the Yamatake CMC15G USB and Yamatake CMC15G USB COM Port drivers have been installed, the installation is complete.

10 - 2 Communication

10-2-1 Communication status

■ Screen layout

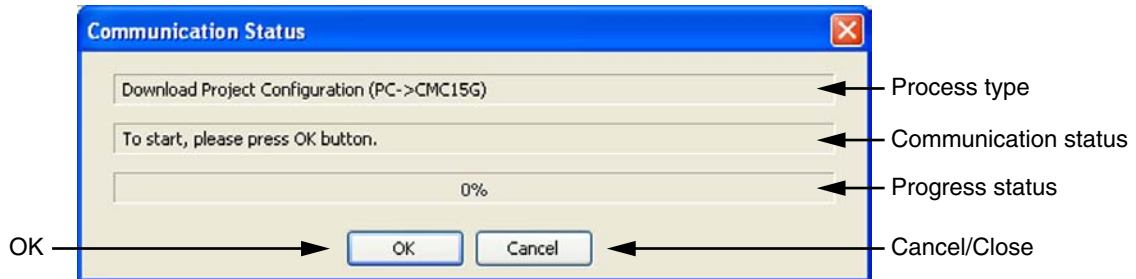

● Process type

The process type for the communication is shown. Process types are as follows:

- Download (PC→CMC15G)
- Upload (CMC15G→PC)
- CMC15G Information
- Online monitor
- Mode change
- Online module setup
- Online date time setting

● Communication status

The contents of the currently running communication are shown. The communication contents may vary depending on the type of process.

● Progress status

The progress status of the communication is displayed in percentages and in bar graph format.

● OK

This button is used to execute the two processes listed below.

- Download project configuration (PC→CMC15G)
- Upload project configuration (CMC15G→PC)

Clicking [OK] will start the process.

● Cancel/Close

Clicking [Cancel] will cancel the currently running communication process.

If the communication process is aborted (through cancellation or abnormal termination), this button changes to the [Close] button.

After checking the status, click [Close] to close the window.

10-2-2 Download (PC→CMC15G)

● Procedures

- (1) Select [Download (PC→CMC15G)] under [Online] in the main menu.
>> The Communication Status window will appear.
- (2) Click [OK] to start the download process.
>> When the communication has been completed successfully, the Communication Status window closes.

● Description

- If any project is open, its configuration is downloaded automatically. If no project is open, the project file selection window will appear.
- If there is an error in the configuration of the project, an error message will appear, and downloading will not begin.
- If the CMC15G is running, a message will appear prompting the user to confirm the transition to STOP mode. Click [OK] to change the mode of the CMC15G to STOP and begin the download process. If you select [Cancel], the download process will not begin.
- After the download process has been completed, a message will appear prompting the user to confirm the transition to RUN mode. Click [Yes] to change the mode of the CMC15G to RUN. If you select [No], the CMC15G will remain in STOP mode.

10-2-3 Upload (CMC15G→PC)

● Procedures

- (1) Select [Upload (CMC15G→PC)] from the [Online] menu.
>> The project file save window will appear.
- (2) Select a project file to which to save the uploaded configuration.
- (3) Click [OK] to close the save window. The communication status window will appear.
- (4) Click [OK] to start the upload process.
>> When the communication has been completed successfully, the communication status window closes.

● Description

- The project file name of the project set on the CMC15G is displayed as the initial value for "file name."
- If the CMC15G is running, a message will appear prompting the user to confirm the transition to STOP mode. Click [Yes] to change the mode of the CMC15G to STOP and begin the upload process. If you select [Cancel], the download process will not begin. If [No] is selected, the upload process will begin in RUN mode. If [Cancel] is selected, the upload process will not begin.
- If the upload is started in RUN mode, it will take much longer than in STOP mode.
- If the upload began after the mode was changed to STOP, a message will appear prompting the user to confirm the transition to RUN mode. Click [Yes] to put the CMC15G into RUN mode. If you select [No], the CMC15G will remain in STOP mode.

10-2-4 Online monitor

You can check the process status of the CMC15G or the communication status of the connected module in the online mode.

■ Screen layout

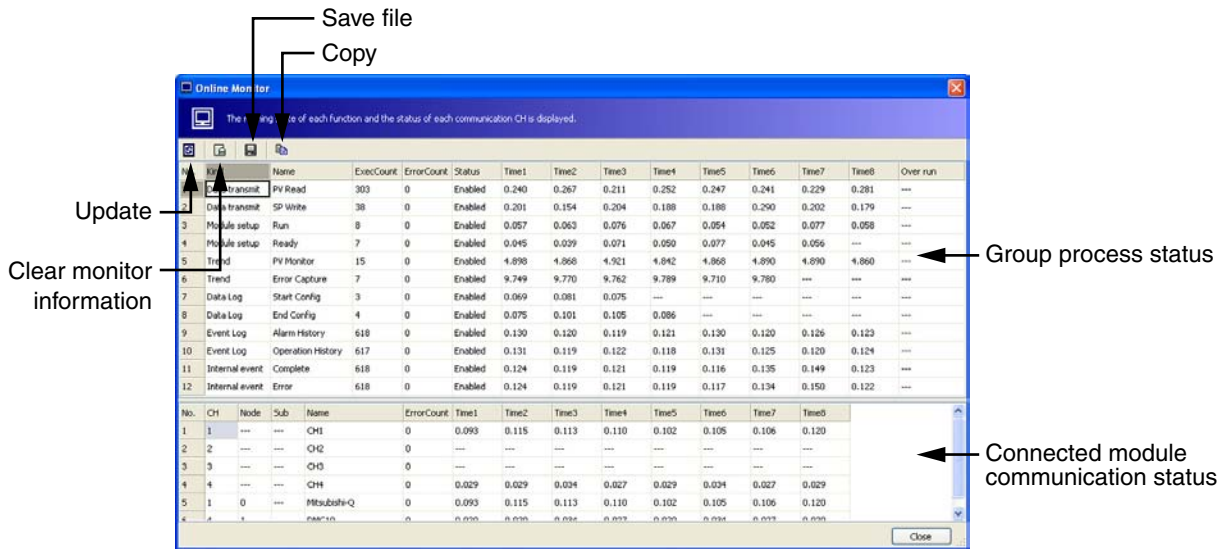

● **Update**

Starts monitoring the process status of each function and the communication status.

● **Clear monitor information**

Clears the monitor information inside the CMC15G.

● **Save file**

Saves the read out information to a file in CSV format.

● **Copy**

Moves the contents of the selected cell to the clipboard.

● **Group process status**

Kind

Displays the type of process. Process types are:

- Data transmission
- Module setup
- Internal event

Name

Displays the group name of each function.

Exec count

Displays the number of communication execution cycles.

The range is 0 to 4294967295. If this count exceeds the high limit, it returns to "0."

Error count

Displays the number of errors during processing.

The range is 0 to 4294967295. If this count exceeds the high limit, it returns to "0."

Status

Displays the status of each group. Statuses are as follows:

- Enabled
- Disabled

Time 1 to time 8

Displays the process time data for past eight processes (in seconds).

Overrun

"Occurred" is displayed if the startup cycle overruns and if cyclic (fixed) is selected. In other cases, "---" is displayed.

- **Connected module communication status**

Connected module information

Displays the following information for connected modules:

- CH
- Node (node address)
- Sub (sub-address)
- Name

Error count

Shows the number of communication errors for each module.

Time 1 to time 8

Displays the process time data for the past eight processes (in seconds).

■ Operating procedures

To start the online monitor, follow the steps below.

- (1) Select [Online Monitor] from the [Online] menu.
- (2) Click the [OK] button.
 - >> The online monitor window will appear.
- (3) To update the data, click the  icon.
- (4) To exit the online monitor window, click the [Close] button.

- **Description**

- If no project is open or if the open project does not match the configuration of the CMC15G, the communication status window appears for the purpose of reading monitoring information from the CMC15G. The operating speed of the CMC15G will become slightly slower as the monitoring information is being read.

Handling Precautions

- Information on group process status and connected module communication status is cleared when the mode is changed to RUN or when the clear monitor status icon is clicked.

The over run column in the group process status display shows overruns after clearing. If you want to clear it, click the clear monitor status icon.

Since the special SM901.0 contact (cycle overrun) relates to information after the mode has been changed to RUN, it cannot be cleared using the clear monitor status icon.

10-2-5 Operation mode change

You can change the operation mode of the CMC15G.

■ Screen layout

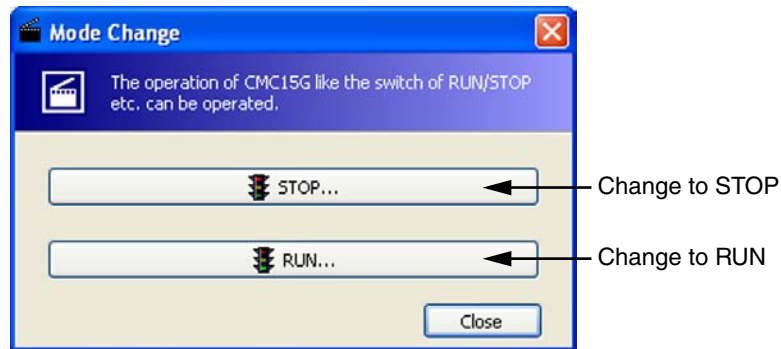

● Change to STOP

Puts the CMC15G in STOP mode.

● Change to RUN

Puts the CMC15G in RUN mode.

■ Operating procedures

To change the operation mode, follow the steps below.

- (1) From the [Online] menu, select [Online operation] → [Mode Change].
 - >> The mode change window will appear.
- (2) Click either the [RUN] or [STOP] button.
 - >> A confirmation dialog box appears.
- (3) If [OK] is clicked, the communication status window is displayed and the mode is changed. If [Cancel] is clicked, the mode is not changed, and the previous window is displayed.
 - >> When communication is completed successfully, the communication status window closes.

10-2-6 Online module setup

Regardless of execution conditions, you can set up modules with GatewayEditor.

■ Screen layout

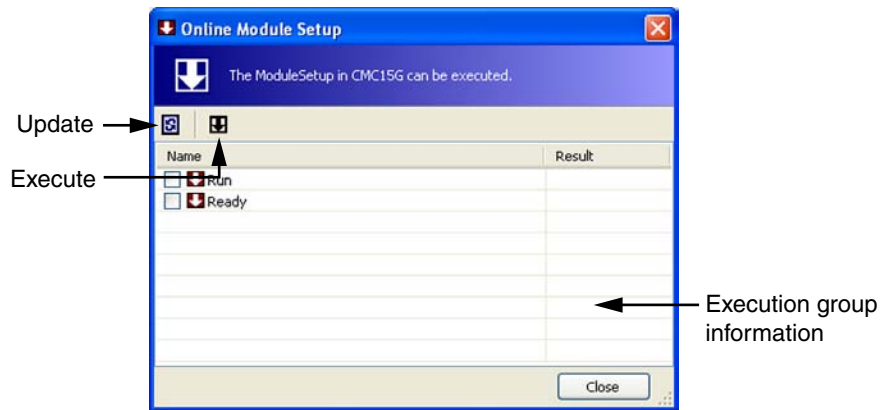

● Update

Reads information from the CMC15G for each group which has been set up in the module setup. The information is listed in the execution group information area.

● Execute

Executes module setup for the group selected in the execution group information area.

● Execution group information

Lists the module setup group names read out from the CMC15G.

Select a group in order to execute it. The results of execution are also displayed.

The list is blank if the information has not been read from the CMC15G.

■ Operating procedures

(1) From the [Online] menu, select [Online operation] → [Online Setup Module].

>> The online module setup window will appear, along with a dialog box prompting you to confirm read-out from the CMC.

(2) Click [OK].

>> The list of module setup groups for the CMC15G will appear.

(3) Select a group to be executed.

(4) Click the [Execute]  icon.

>> A confirmation dialog box will appear.

(5) Click [OK]. The communication status window appears and processing is then executed. If [Cancel] is clicked instead, group processing is not executed, and the previous window is displayed.

>> The execution results are displayed in the execution group information area.

● **Description**

- When the CMC15G is in RUN mode, a message will appear allowing you to change to STOP mode. If the [OK] button is clicked the CMC15G enters STOP mode and then module setup is executed. If [Cancel] is clicked, module setup is not done.
- After module setup has been completed, there is no completion notification or error notification.
- Online module setup is done regardless of the execution conditions and enabled conditions set for the module setup group.
- Click the [Update] button. When the module setup group is read again, the execution results area is cleared.

10-2-7 Online date and time setting

You can display and set up the date and time for the CMC15G.

■ Screen layout

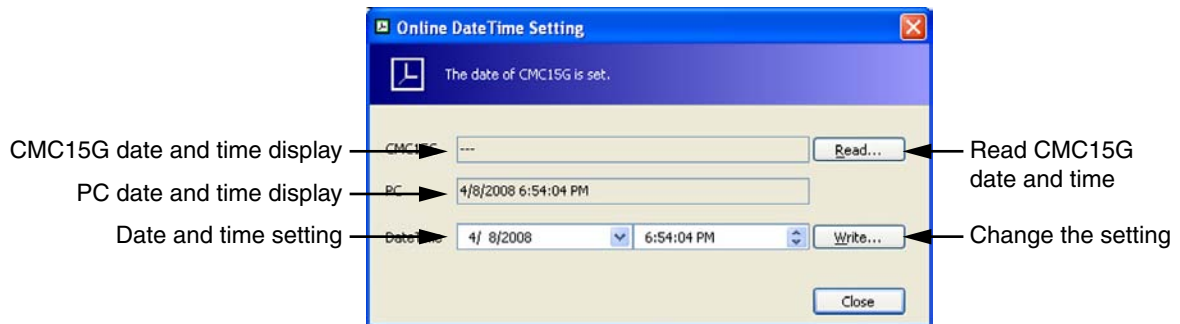

● Read CMC15G date and time

Reads the date and time from the CMC15G and shows them in the CMC15G box.

● CMC15G date and time display

Displays the date and time read from the CMC15G.

Displays "---" until the date and time are read from the CMC15G.

● PC date and time display

Displays the date and time on the personal computer.

● Date and time setting

Specify the date and time to be set for the CMC15G. By default the PC date and time are shown.

If the time is changed, the displayed time stops advancing.

The settable date and time range is 00:00:00 on January 1, 2000 to 23:59:59 on December 31, 2099.

● Change the setting

The date and time set in the date and time box are written to the main unit.

■ Operating procedures

- Procedures

(1) From the [Online] menu, select [Online operation] → [Online Adjust DateTime].

>> The online date time setting window will appear.

(2) To find out the date and time on the CMC15G, click the [Read...] button.

(3) To set a date and time different from those on the personal computer, specify the date and time in the [Date Time] box.

(4) Click the [Write...] button.

>> The communication status window is shown while the date and time are being set.

10-2-8 CMC15G information display

■ Screen layout

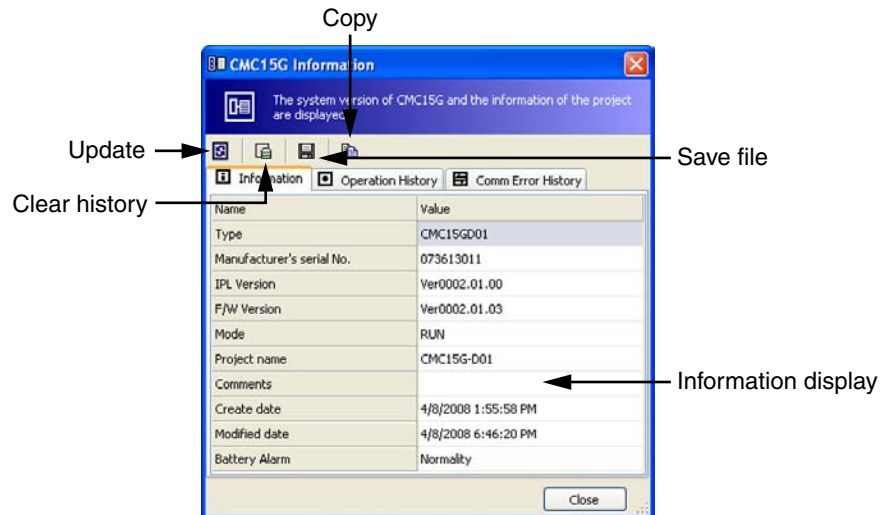

● Update

Reads the basic information and history from the CMC15G.

● Clear history

Clears the CMC15G history.

● Save file

Saves the read out information to a file.

● Copy

Moves the contents of the selected cell to the clipboard.

● Information display

Lists information on the CMC15G in separate tabs for basic information, system history, and communication error history.

■ Operating procedures

(1) Select [CMC15G Information] from the [Online] menu.

>> The CMC15G Information window will appear, along with a dialog box prompting you to confirm read-out of the information.

(2) Click the [OK] button.

>> Information on the CMC15G is shown in the information display area.

● Reading data from the CMC15G

- Procedures

(1) Click the update button.

>> The communication status window will be displayed as information is read from the CMC15G.

● Saving to a CSV file

- Procedures

(1) Click the [Save file] button.

>> The save as window will appear.

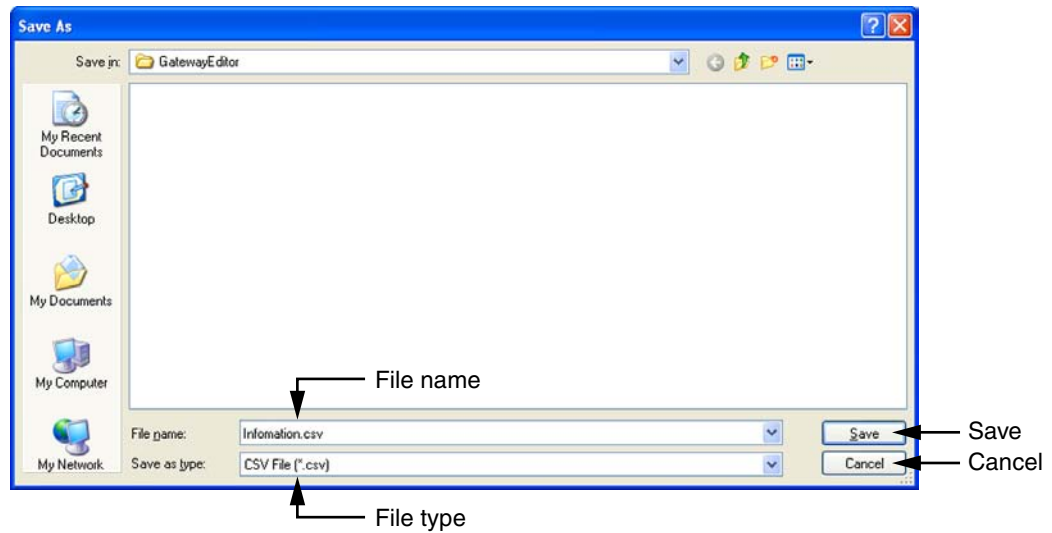

(2) Open the folder to which you wish to save the file and input a file name.

(3) Click the [Save] button.

>> The CMC15G information is saved with the specified file name.

● Clear history

- Procedures

(1) Click the [Clear history] button.

>> A confirmation dialog box will appear for execution of the history clear process.

(2) Click [OK]. The communication status window will appear and the history is cleared. If [Cancel] is clicked instead, the history log is not deleted, and the previous window is displayed.

>> When the communication is completed successfully, the communication status window closes.

■ Basic information

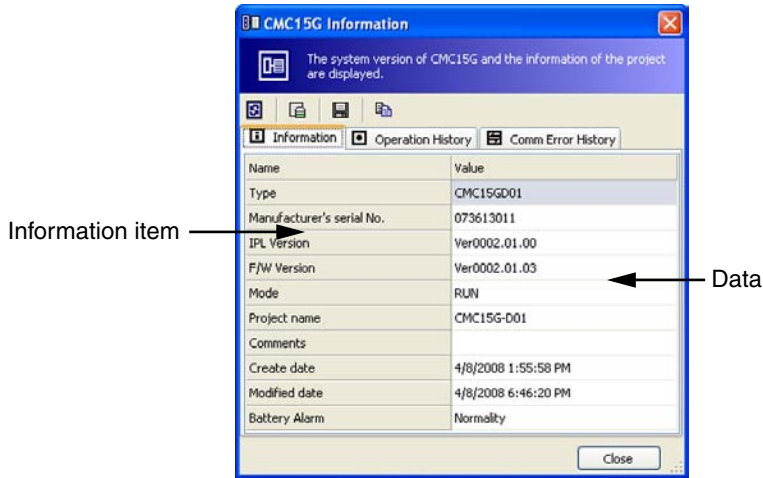

● Type

Displays the CMC15G type.

● Manufacturer's serial No.

Displays the manufacturer's serial No. for the CMC15G.

● IPL Version

Displays the CMC15G's IPL version. (IPL is equivalent to the BIOS on the PC.)

● F/W Version

Displays the CMC15G's firmware version.

● Mode

Displays the mode of the CMC15G.

- STOP: STOP mode
- RUN: Project is running.
- THROUGH: Through-communication mode

● Project name

Displays the file name of the project downloaded to the CMC15G.

● Comments

Displays the comments for the project downloaded to the CMC15G. (Comments are displayed with line feeds converted to spaces).

● Create date

Displays the date and time when the project was created.

● Modified date

Displays the date and time when the project was downloaded to the CMC15G.

● Battery Alarm

Tells whether or not the voltage level of the CMC15G battery is lower than the threshold value.

- Normality: Voltage level is above the threshold.
- Voltage decrease: Voltage level is below the threshold.

■ Operation history

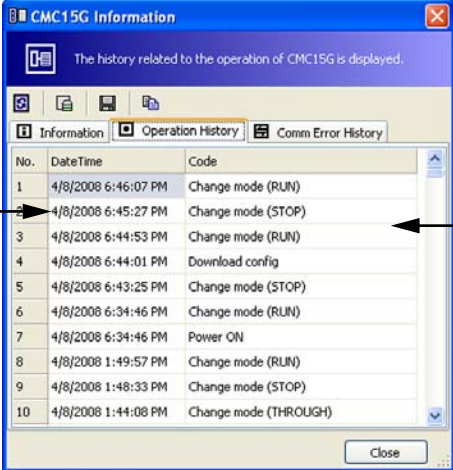

No.	DateTime	Code
1	4/8/2008 6:46:07 PM	Change mode (RUN)
2	4/8/2008 6:45:27 PM	Change mode (STOP)
3	4/8/2008 6:44:53 PM	Change mode (RUN)
4	4/8/2008 6:44:01 PM	Download config
5	4/8/2008 6:43:25 PM	Change mode (STOP)
6	4/8/2008 6:34:46 PM	Change mode (RUN)
7	4/8/2008 6:34:46 PM	Power ON
8	4/8/2008 1:49:57 PM	Change mode (RUN)
9	4/8/2008 1:48:33 PM	Change mode (STOP)
10	4/8/2008 1:44:08 PM	Change mode (THROUGH)

● Date and time of occurrence

Shows the date and time of the operation.

! Handling Precautions

- The maximum number of records is 256. If the maximum number of records exceeds 256, the oldest contents are overwritten with the latest contents.

● Operation description

Describes the CMC15G operation. The types of operations that are logged are:

- Power ON
- Download config
- Change time setting
- Change mode

■ Communication error history

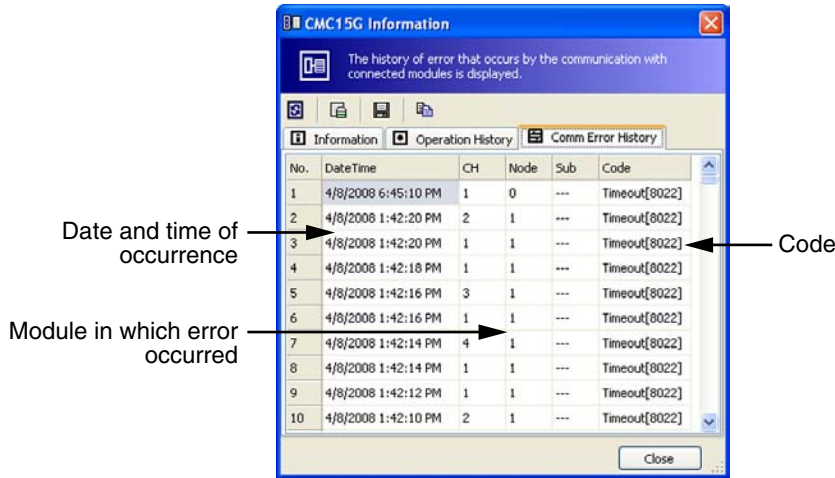

● Date and time of occurrence

Displays the date and time when the communication error occurred.

● Module in which error occurred

Displays the communication channel (CH), node address (Node), and sub-address (Sub) for the connected module in which the communication error occurred.

● Code

Code	Error description
Illegal parameter [8010]	Processing was aborted or the message was discarded because the CMC15G could not correctly receive the response. Even when a connected device has correctly completed message processing, an error can be detected by the CMC15G in the response message from the connected device. Check the communication setup details, such as communication speed and wiring. Additionally, an error may occur if the communication frame is corrupted by an external disturbance, such as electrical noise.
Fail to execute command [8013]	
Receive buffer overflow [8020]	
Receive buffer error [8021]	
Timeout [8022]	
Over-run/Framing error [8030]	
Parity error [8031]	
Check-sum error [8032]	
Sub-address error [8033]	
Node-address error [8034]	
Data overflow [8080]	The connected device could not correctly process the message. The code and method of error handling differs depending on the device. Refer to the error codes described in the user's manual for each device.
Fail to initialize [80A0]	
Communication failure [80FF]	
Other errors (code No. is indicated.)	

! Handling Precautions

- The maximum number of records is 256. If the maximum number of records exceeds 256, the oldest contents are overwritten with the latest contents.

● Communication error analysis

If there is only an error code in the history log for an error occurrence, follow the steps below to locate the error.

- (1) Get the channel and node where the error occurred from the communication error history.
- (2) Refer to the user's manual for the relevant module to learn what the error code means.
- (3) Locate the CMC15G configuration sheet in which the error occurred using the GatewayEditor's Online monitor.



Note

The following shows an example of error codes for Yamatake's modules:

● Common to all modules

Code	Error description	Comment
0099	Command is undefined. Normally, this error does not occur while configuring the CMC15G. It may occur if the communication frame is corrupted by external disturbance, such as electrical noise.	End code is returned and the message processing is not executed.

● DMC10

Code	Error description	Comment
0022	Written data is out of range.	The relevant word address is skipped and processing continues.
0023	Writing is impossible because of instrument settings or external conditions.	The relevant word address is skipped and processing continues.
0040	The number of read words is abnormal.	End code is returned and the message processing is not executed.
0041	Conversion error due to out-of-range word address. Address is outside the -32768 to +32767 range.	End code is returned and the message processing is not executed.
0042	Data value is out of range / data error / single word range exceeded.	Processing is executed up to the relevant word address. However, subsequent processing is not done.

● SDC45

Code	Error description	Comment
0010	<ul style="list-style-type: none"> Numeric value conversion error. Apart from commands, there are characters other than '0' to '9' and 'A' to 'F' in the application layer. The message length of the application layer is illegal. There is a character other than '00' in the sub-command of the RU/WU command. 	End code is returned and message processing is not executed.
0021	A data address that is not in the read command is included.	The read-out value at the relevant data address is set to "0" and is returned.
	A data address that is not in the write command is included.	The relevant data address is skipped and processing continues.
0022	A read-out value other than those at data addresses 8000 to 7FFF (decimal -32768 to + 32767) is included in the read-out command.	The read-out value at the relevant data address is returned as 8000 (decimal -32768) or 7FFF (decimal +32767).
	Write value at a data address other than the setting range is included in the write command.	The relevant data address is skipped and processing continues.
0023	An included data address cannot be read due to instrument conditions or communication lock.	The read-out value at the relevant data address is set to "0" and is returned.
	An included data address cannot be written due to instrument conditions or communication lock.	The relevant data address is skipped and processing continues.
0040	The number of read/write data records is illegal.	End code is returned and the message processing is not executed.

● SDC15, SDC25/26, SDC35/36

Code	Error description	Comment
0010	Numeric value conversion error <ul style="list-style-type: none"> There are 7 or more numerical digits Numeric value other than 0 starts with "0" Conversion result is outside the 65535 to -65536 range. Some other incorrect non-integer expression 	Conversion error. Processing is stopped if a range error occurs. Processing is executed up to the error.
0022	The value of the written data is beyond the setting range.	The relevant word address is skipped and processing continues.
0023	Writing is impossible due to instrument settings or external instrument conditions.	The relevant word address is skipped and processing continues.
	Reading/writing is impossible while the communication loader is locked.	End code is returned and the message processing is not executed.
0040	The number of read/written words is abnormal.	End code is returned and the message processing is not executed.
0041	The data address is out of range. <ul style="list-style-type: none"> The data address is outside the allowable range of 256 to 65534. 	End code is returned and the message processing is not executed.
0042	Data value is outside the setting range of -32769 to 32768.	Processing is executed up to the relevant data address. However, subsequent processing is not done.

10-2-9 Upgrading the system

To upgrade the system, new system files are downloaded from the PC to the CMC15G.

■ Automatic update

When project files are downloaded to the CMC15G, the system files on the CMC15G and on the PC are compared. If the CMC15G's system files are older, a confirmation message for system file update appears.

If [Yes] is clicked, the project file is downloaded after all system files have been updated. If [No] is clicked, the project file is downloaded without updating the system files. Clicking [Cancel] exits the dialog without doing anything.

(1) Disconnect the modules from the CMC15G or turn OFF the power.

(2) Open a project to be downloaded to the CMC15G.

(3) Select [Online]→[Download PC -> CMC15G].

>> The communication status window will appear.

(4) Click the [OK] button.

>> The system files on the CMC15G are compared to those on the PC. If the CMC15G's system files are older, a confirmation message for system file update appears.

(5) Click the [Yes] button. After all systems have been updated, download the project file.

Handling Precautions

- If the system files installed on the CMC15G and on the PC are the same version, no files are updated.
- If [Cancel] is clicked in the message window, the process is cancelled.
- If you update the system files without disconnecting the modules from the CMC15G, the update process may fail. If this occurs, reset the CMC15G once or turn OFF the power and turn it ON again to restart the update process.

■ Manual update

In addition to a system file update triggered by downloading a project, an update can be done manually.

 Section 11-3, Updating the CMC15G system files.

Chapter 11 TOOLS

11 - 1 Environment Configuration

■ Communication configuration

You can configure the connections between the CMC15G and PC.

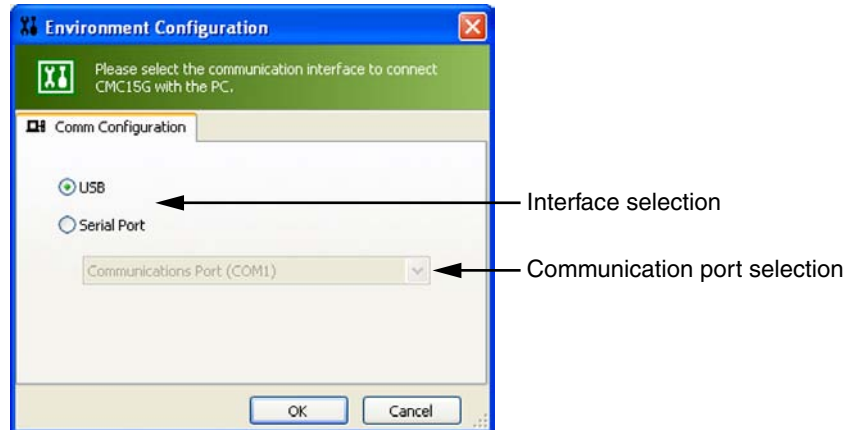

● Interface selection

Select a communication interface on the PC used to connect the CMC15G.

- USB
- Serial Port

The initial value is "USB."

● Communication port selection

If you check [Serial Port] as the interface selection, select the COM port connected to the CMC15G. The initial value is the port that is found first. If no COM port is found, the initial value is blank.

! Handling Precautions

- If you start communications before a valid communication interface is found, an error message will appear. Only valid COM ports on the PC are displayed in the drop-down list for port selection.

- Procedures

(1) Select [Tool] → [Environment].

>> The environment configuration window will appear.

(2) Select an interface.

(3) If [Serial Port] is checked in step (2), select a COM port.

(4) Click the [OK] button.

11 - 2 Changing the Target Model

To change the target model of the project currently being edited, follow the steps below.

- (1) Select [Tool] → [Change Target Model].
>> The dialog box will appear for confirmation of target model change.
- (2) Click [OK].
>> The target model is changed.

Handling Precautions

- If the model is changed from "recording (CMC15GD01)" to "standard (CMC15GS01)," the contents of the trend settings, data log, and event log are cleared completely.
- If [Cancel] is clicked in the dialog box, no change is made.
- If configuration sheets are open, all sheets are closed.

11 - 3 Updating the CMC15G System

To manually change the CMC15G system version, follow the steps below.

- (1) Disconnect the modules from the CMC15G or turn OFF the power.
- (2) Select [Tool] → [Update system on CMC15G].
>> The communication status window will appear.
- (3) Click [OK] to begin a check of the system version.
>> A message about the system update of the PC will appear.
- (4) Click [OK]. The system files are then transmitted to the CMC15G.

Handling Precautions

- Do not turn OFF the power to the CMC15G while the system files are being updated. Doing so may cause a malfunction.
- If the system files installed on the CMC15G and on the PC are the same version, no files are updated.
- If [Cancel] is clicked in the message window, the process is cancelled.
- If a project has been downloaded to the CMC15G, the system files are updated after the project has been read. The project is automatically downloaded after the system files have been updated.
- If you update the system files without disconnecting the modules from the CMC15G, the update process may fail. If this occurs, reset the CMC15G once or turn OFF the power and turn it ON again to restart the update process.

Chapter 12 CONTACTS AND REGISTERS INSIDE THE CMC15G

The following internal device areas are available on the CMC15G. The CMC15G can refer to special internal contacts and registers and can read/write data using external serial commands.

☞ CMC15G Multifunction Gateway Communication Controller User's Manual for Communication Connections, CP-SP-1278E (for details on serial commands)

■ List of devices

Device name	Device	Read	Write	Communication		Size	Backup	Initialization
				Read	Write			
Internal event area	EM000.0 to EM001.3	○	×	○	×	20 bits	None	Turned OFF upon change to RUN.
Digital signal input/output bus	BM00000 to BM00003	○	○	○	×	4 bits	None	Turned OFF upon change to STOP.
User contact area	NM0000.0 to NM9999.F	○	○	○	○	10,000 words	None	Turned OFF at startup and upon change to RUN.
User register area	NR00000 to NR32767	○	○	○	○	32,768 words	None	Turned OFF at startup and upon change to RUN.
User backup contact area	SM000.0 to SM899.F	○	○	○	○	900 words	Yes	When project is downloaded.
User backup register area	SR00000 to SR32767	○	○	○	○	32,768 words	Yes	When project is downloaded.
Special contact area	SM900.0 to SM999.F	○	×	○	×	100 words	Yes	See page 12-2.
Special register area	SR90000 to SR99999	○	×	○	×	10,000 words	Yes	See page 15-3.

! Handling Precautions

- The digital signal input/output bus (BM) is word data. One word is equivalent to one point on the input/output bus. If the value is not 0, the point is turned ON. If the value is 0, the point is turned OFF.

■ Special contacts

Special contacts show the internal status of the CMC15G, such as the occurrence of an error. You can read a value from a special contact, but cannot write a value to it.

Device name	Device	Read	Write	Communication		Operating detail	Initialization
				Read	Write		
CH1 Communication error	SM900.7	○	×	○	×	Communication error on CH1.	Initially OFF
CH2 Communication error	SM900.8	○	×	○	×	Communication error on CH2.	Initially OFF
CH3 Communication error	SM900.9	○	×	○	×	Communication error on CH3.	Initially OFF
CH4 Communication error	SM900.A	○	×	○	×	Communication error on CH4.	Initially OFF
Battery alarm	SM900.B	○	×	○	×	Low battery voltage	Constantly updated.
Cycle overrun	SM901.0	○	×	○	×	Overrun during fixed cycle processing.	Turned OFF at startup and upon change to RUN.
Running	SM902.0	○	×	○	×	ON while running.	Turned OFF upon change to STOP.
ON after one scan	SM902.1	○	×	○	×	Turned ON after group processing begins.	Turned OFF upon change to RUN.
OFF after one scan	SM902.2	○	×	○	×	Turned OFF after group processing begins.	Turned ON upon change to RUN.
Always ON	SM905.0	○	×	○	×	Always ON	Initially OFF
1 s clock	SM905.1	○	×	○	×	Turned ON and OFF repeatedly at 1 s intervals.	Initially OFF
5 s clock	SM905.2	○	×	○	×	Turned ON and OFF repeatedly at 5 s intervals.	Initially OFF
10 s clock	SM905.3	○	×	○	×	Turned ON and OFF repeatedly at 10 s intervals.	Initially OFF
Always OFF	SM905.F	○	×	○	×	Always OFF	Initially OFF

! Handling Precautions

- If you use a special contact as a trigger device, do not enable trigger device initialization. If you do, trigger device initialization will fail because writing is not possible, and processing will not be executed.
- Special contact SM901.0 (cycle overrun) is not cleared even if the clear monitor information command is executed in the Online Monitor window.

Since the overrun display function of the group process status displays the history after the monitor information clear has been executed, it is cleared when the clear monitor information command is executed.

■ Special registers

The special register area is where configuration information inside the CMC15G and information on communication errors is saved. It is a read-only area.

Device name	Device	Read	Write	Communication		Operating detail	Initialization
				Read	Write		
Year	SR90143	○	×	○	×	Shows the last two digits of the year Range: (200)0 to (20)99.	Constantly updated.
Month	SR90144	○	×	○	×	Range: 1 to 12	Constantly updated.
Day	SR90145	○	×	○	×	Range: 1 to 31	Constantly updated.
Day of the week	SR90146	○	×	○	×	Value: 0 to 6 0: Sun. 1: Mon. ⋮ 6: Sat.	Constantly updated.
Hour	SR90147	○	×	○	×	Range: 0 to 23	Constantly updated.
Minute	SR90148	○	×	○	×	Range: 0 to 59	Constantly updated.
Second	SR90149	○	×	○	×	Range: 0 to 59	Constantly updated.

Chapter 13 MAINTENANCE

■ Replacing the battery

⚠ CAUTION

- ⊘ Do not throw a used battery into the fire or into the garbage. Dispose of it properly, following local regulations.
- ⊘ Do not short-circuit the battery or allow it to get wet. If the battery is short-circuited, it may heat up or ignite.

ⓘ Handling Precautions

- If the POWER indicator indicates low backup battery voltage, replace the battery as soon as possible. Replacement of the battery within one month of the first indication of low voltage is recommended.
- When replacing the battery, strictly observe the following points:
 - Supply power for 10 minutes or longer before turning OFF the power.
 - Complete the battery replacement work within 15 minutes. If the battery replacement work is not done within this period of time, the clock data, backup area, and/or history data may be lost.
 - Use Yamatake replacement battery No. 81446431-001.

● Replacement procedure

- (1) Back up all CMC15G data to the PC using GatewayEditor.
- (2) Supply power to the CMC15G for 10 minutes or longer. Then turn OFF the power.
- (3) Remove the CMC15G from the base.
- (4) Slide the metal fastener in the direction indicated by the arrow shown in the figure and disconnect the battery cable.

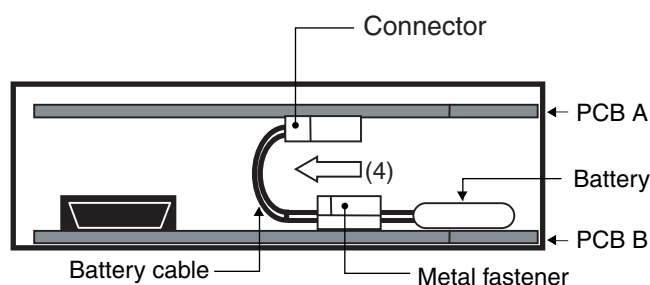

- (5) Disconnect the battery cable connector from printed circuit board A to remove the battery.
- (6) Connect the connector of the replacement battery to the connector on printed circuit board A.
- (7) Secure the battery cable with the metal fastener and push the metal fastener against printed circuit board B until a click is heard. Push in the cable to the far portion of the metal fastener where possible. This ensures easy assembly.

(8) Mount the CMC15G on the base.

(9) Check with GatewayEditor that the clock data is correct. If necessary, correct the clock data and then transmit the data that was backed up to the PC in step (1) to the CMC15G.

■ Disposal

When discarding, remove the battery and dispose of both the product and the battery as industrial waste, following local regulations.



Chapter 14 SPECIFICATIONS

■ Specifications

	Item	Specifications
Communications	CH1	RS-232C, full duplex (half duplex protocol), cable length 15 m or less, D-Sub 9-pin, Max. transmission speed 115.2 kbps
	CH2	RS-485, 5-wire system full duplex (half duplex protocol), cable length 500 m or less, connector (5-pin of 7-pin connector), Max. transmission speed 115.2 kbps
	CH3	RS-485, 3-wire system half duplex, cable length 500 m or less, connector (3-pin of 7-pin connector), Max. transmission speed 19.2 kbps
	CH4	RS-485, 3-wire system half duplex, cable length 500 m or less, screw terminals on the base, Max. transmission speed 38.4 kbps
	USB	USB 2.0-based full speed (12 Mbps) mini-B, 5-pin
Digital signal I/O bus	Number of I/O bus	4 points
	Function	Outputs the logical add (OR) of the same bus event outputs from each DMC10.
General specifications	Rated power voltage	24 Vdc
	Operating power voltage	21.6 to 26.4 Vdc
	Power consumption	3 W or less
	Insulation resistance	Min. 20 MΩ by 500 Vdc megger (between each I/O terminals and 24 Vdc power terminals)
	Dielectric strength	500 Vac for 1 min. (between case and 24 Vdc power terminals)
	Isolation	All communications lines are isolated from power lines. Individual communications channels are not isolated from each other. Individual EV buses are not isolated from each other, but are isolated from communications.
	Built-in clock accuracy	Within ± 40s per month (reference value at 25 °C)
	Memory backup	Min. 5 years (at 25 °C)
	Operating condition	Ambient temp.: 0 to 50 °C, Ambient humidity: 30 to 90 %RH
	Transport/storage conditions	Ambient temp.: -20 to +70 °C, Ambient humidity: 10 to 95 %RH Vibration resistance: Max. 4.9 m/s ² Impact resistance: Max. 392 m/s ² for screw mount Max. 196 m/s ² for DIN rail mount Package drop test: Drop height 60 cm, free fall
	Screw tightening torque	Power terminals and CH4 communication terminals : 0.8 to 1.0 N•m
	Mounting	DIN rail mount or screw mount
	Materials	Mask, Case, Base: Polycarbonate
	Color	Mask: Navy blue, Case: Light gray, Base: Light gray
Mass	Approx. 200 g	
Applicable standard	EN61326	
Accessories	User's Manual (No.CP-UM-5463E) 1 piece	
	CH2, CH3 Communication connector 1 piece	
Maintenance parts	Battery Model No.: 81446431-001	
Software	Smart Loader Package (The GatewayEditor) Model No.: SLP-G15J50	
	Smart Loader Package (The LogViewer) Model No.: SLP-G15LGV	

■ External dimensions

Unit: mm

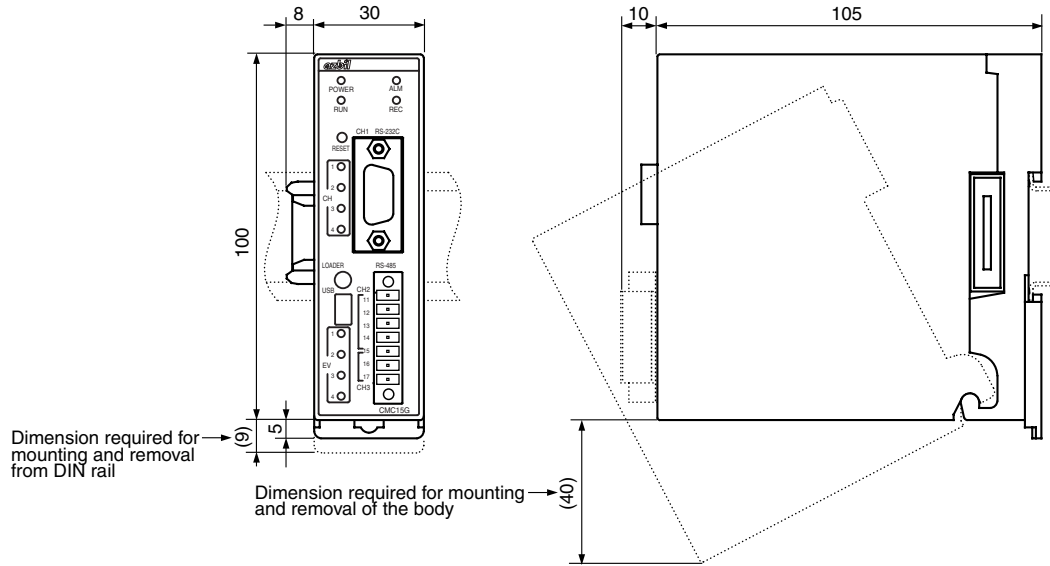

Chapter 15 TROUBLESHOOTING

■ Diagnosis using the indicator lights

The CMC15G's indicator lights notify the user if an error occurs.

POWER indicator:

Green when power is ON.

Orange if battery voltage is low.

RUN indicator:

Green for RUN mode.

Flashing green for loader through-mode.

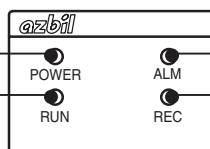

ALARM indicator:

Red if self-diagnosis finds an error.

REC indicator:

Lit during trend recording.

Flashing if there is a capture.

● POWER indicator

Status	Meaning	Corrective action
Green	CMC15G power is ON.	—
Off	CMC15G power is OFF.	Turn ON the power.
Orange	Backup battery voltage is low.	Replace the backup battery. ➔ Chapter 13, Maintenance

● ALARM indicator

Status	Meaning	Corrective action
Off	The CMC15G is running normally.	—
Red	An error occurs in the self-diagnosis.	If the ALARM indicator is lit red, turn OFF the power and then turn it ON again, or reset the CMC15G with the RESET button. If the alarm still appears, contact a Yamatake salesperson.

● RUN indicator

Status	Meaning	Corrective action
Off	CMC15G functions have stopped.	To change to RUN mode, use the GatewayEditor. ➔ 10-2-5, Operation mode change (page 10-12)
Green	CMC15G functions are running.	—
Flashing green	The controller loader (SLP, etc.) is doing loader through-communication with a slave station through the CMC15G.	To switch from through-communication mode to RUN mode, run ThroughComm.exe. ➔ 7-6, Loader through-communication (page 7-10)

● REC indicator

Status	Meaning	Corrective action
Off	Not recording.	—
Green	Trend is being recorded.	—
Flashing green (1 s intervals)	The captured trends function is running after a trigger occurred.	—
Flashing green (200ms intervals)	Captured trends function is running but capture memory is full.	—

■ Error diagnosis using the CH1 to CH4 indicators

The indicators show whether there was a communication error.

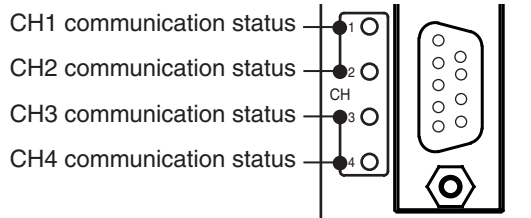

Four indicators corresponding to the COM ports to which the modules are connected indicate the communication status of each module.

Status	Meaning	Corrective action
Not lit	No communication	If the indicator is not lit even though there is a communication request*, the communication parameters may be incorrect. Using GatewayEditor, check the communication parameters for the target channel.
Flashing green	Communicating	—
Orange	No response, or error in received message	Any of the following may be the cause: <ul style="list-style-type: none"> • The cable is connected incorrectly. • The communication setup for the module (node address, transmission speed, parity, etc.) is incorrect. • The communication parameters (data address, data area, etc.) are incorrect. Depending upon the device, mode, and conditions, it may not be possible to write data. Using the GatewayEditor's Online monitor, identify the module with the communication error, and check the wiring and the communication configuration and parameters. ➔ 10-2-4, Online monitor (page 10-10)

* For example, a communication request occurs when there is a periodic data transmission or when a trigger device initiates module setup. Additionally, since the CMC15G monitors trigger devices periodically, if a host station device is set as a trigger device, it is normal for the indicator of the channel connected to the host station to be flashing frequently.

■ Corrective actions in case of an error occurs

Context (activity)	Symptom	Cause	Corrective action
Installation	Indicators EV1 to EV4 start flashing when the power is turned ON.	Low voltage due to insufficient supply power.	Increase the supply power in order to maintain the voltage necessary for operation.
	POWER indicator does not light up green when the power is turned ON.	If the power supply and wiring are correct, the CMC15G may be faulty.	Contact a Yamatake sales office or dealer.
Connection with personal computer	USB connection with the CMC15G does not work.	USB drivers are not installed correctly.	Run setup.exe from the usb directory (default location is C:\Program Files\SLP\SLPG15\usb), located at the installation destination for GatewayEditor's USB drivers. The USB cable should not be connected to the CMC15G while the installer is running.
		Multiple CMC15G units cannot be connected to the personal computer. The connected units will not communicate properly, or unexpected errors will occur.	Connect only one CMC15G to the personal computer.
	Installation fails because the file cannot be found by the Windows New Hardware Wizard.	This error occurs if the CMC15G is connected through the USB connector when the installer is running.	Specify the vcp1 directory (default location is C:\Program Files\SLP\SLPG15\usb\vcp1) at the GatewayEditor installation destination as the location of the installation files.
Regular operation	CH1 to CH4 indicators are orange.	The wiring may be incorrect. The terminating resistor may not be connected correctly.	Check the wiring again while referring to Chapter 4, WIRING. Additionally, carefully check the following points: <ul style="list-style-type: none"> • Always connect the signal ground. If not connected, communication may not be reliable. • Connect a terminating resistor (150 Ω, 1/2W) to CH2. • Do not connect any external terminating resistor, since the equivalent of a terminating resistor is built into CH3 and CH4. Do not connect a resistor even if the other units connected to the CMC15G require a terminating resistor.
		The communication parameters or the node address of the connected module may be incorrect.	<ul style="list-style-type: none"> • Check settings such as transmission speed and parity. • Check that the address of the connected module matches the setting. • Check especially that there are not duplicate node addresses.
	The CMC15G cannot be connected to the DMC10 on CH4.	The communication disconnection switch on the base of the CMC15G or DMC10 may not be set at "CONNECT."	Check the communication disconnection switch on the base of the CMC15G and DMC10.
	There is no communication even though a project was downloaded.	If the RUN indicator is lit, the problem may be that a startup delay has been set.	Check the startup delay setting.
	There is always a communication error when the power is turned ON.	If any module is set to be started after the CMC15G, a communication error occurs.	Delay the communication start time of the CMC15G using the startup delay setting.

Context (activity)	Symptom	Cause	Corrective action
Regular operation	Data transmission or module setup for which a trigger was set did not start up.	If the trigger is a write-prohibited device and trigger device initialization is enabled, the trigger cannot be executed.	Go to [System Config] → [Option] → [Initialize] and turn OFF trigger device initialization, or specify a different trigger device which is write-enabled.
		If the same trigger is set for multiple groups and [Option Configuration] → [Initialize] tab → [Initialize trigger device] is ON, depending on the timing, the trigger device may be turned OFF right away, so that it does not start trigger is not started up.	When the same trigger is used for multiple groups, do not set [Option Configuration] → [Initialize] tab → [Initialize trigger device] ON.
		If a special contact is used as a trigger, initialization of the trigger device will fail because writing is not possible. Therefore processing is not executed.	When a special contact is used as a trigger, do not enable trigger device initialization.
	In the communication error history, an error is identified only by an error code.	When an error is returned from a module connected to the CMC15G, an error code is shown. This kind of error occurs if the setting or model No. on the connected module is incorrect. For example: The file register size is out of range, or a value beyond the writable range is written, or a value is written to a write-prohibited area.	Follow the steps below to locate the error. <ul style="list-style-type: none"> • Get the channel and node where the error occurred from the communication error history. • Refer to the user's manual for the relevant module to learn what the error code means. • Locate the CMC15G configuration sheet in which the error occurred using the GatewayEditor's Online monitor.
	The retry-over error sometimes appears in the communication error history.	A one-time communication load may be too large for the CMC15G to receive all of the data correctly. This error may happen if all settings are set to "Cyclic (Auto)."	Cyclic (Auto) functions at the fastest speed, according to the priority. To get control of the load, set the data not needing a fast update cycle to "Cyclic (Fixed)" to slow down its cycle.
	Completion notification failed but there was no notification of the error.	An error that occurs while writing to the completion notification device is not indicated by error notification.	To check whether or not a communication error has occurred, select [Online] → [CMC15G Information] → [Communication Error History].
There was no communication error notification for an extended function.	Communication error notifications are issued if there is an error with a trigger. In the case of a constant error, such as faulty wiring, notification is issued only once. Also, it may be that the module in which the communication error occurred was reset correctly, but the specified bit on the host station was not turned OFF.	To check whether or not a communication error has occurred, select [Online] → [CMC15G Information] → [Communication Error History].	
Gateway-Editor	There are floating point numerical values that cannot be input.	Values are rounded to a value within the handling range. The effective ranges for floating point numbers are: -3.402823E+38 to -1.175494E-38, 0, and +1.175494E-38 to +3.402823E+38.	Use a value within the usable range.
	CMC15G operating history or communication error history cannot be cleared.	If the [Clear history] button is clicked, the history inside the CMC15G is cleared. The history displayed on Gateway-Editor is not cleared and the previously read information is displayed as is.	After clicking [Clear history], click the [Refresh] button to update the display.

Context (activity)	Symptom	Cause	Corrective action
Gateway-Editor	The group order cannot be changed.	The order cannot be changed with the mouse. Change the order from the [Edit] menu or toolbar.	Move the selection sheet up or down as follows: <ul style="list-style-type: none"> • From the menu: [Edit] → [Move up], [Edit] → [Move down] • From the toolbar: [↑] button, [↓] button • From the keyboard: [Ctrl] + [↑] keys, [Ctrl] + [↓] keys
General logging functions	Data collection does not start.	If the enabled-disabled setting results in "disabled" status, the data collection is not started.	If the REC indicator is not green while the continuous trend or captured trends function is running, the enabled-disabled setting has disabled the process, or other settings are incorrect. Check the cycle(s) and enabled-disabled setting. Check also the trigger device in the captured trends or data log.
	All data is not collected completely.	The interval for data collection is too short for the volume of data.	Extend the collection interval. If a CMC15G communication error occurred, it can be checked using the online monitor or communication error history.
	All data is not collected completely.	If a power failure occurs, data is handled discontinuously.	Check the operation history in GatewayEditor to see whether a power ON (power turned OFF, and then turned ON again) occurred.
	When downloading with GatewayEditor, the backup memory size exceeded the high limit, and the transmission of configuration data to the CMC15G was stopped.	If the volume of internal memory used by all logging functions exceeds the capacity of the CMC15G, downloading is not executed.	Adjust the settings on the basis of all groups or logging functions so that internal memory usage does not exceed the maximum level. The usage volume is indicated by the color of the backup memory usage ratio display in GatewayEditor. If the color is red, the memory usage exceeds the capacity. Additionally, you can check the number of bytes set for the memory under the project information in GatewayEditor.
Captured trends function	Even though triggers for all captures are turned ON, the capture memory does not fill up.	After a trigger starts up but before its data has been saved, there is another trigger. Triggers that are activated before data saving is complete are ignored.	Change the conditions for trigger occurrence using an internal event on the PLC or CMC15G. Also, if you increase the number of records saved after the initial trigger, more data can be obtained even though the second trigger is ignored.
LogViewer	The real-time monitor stopped.	The real-time monitor does not save data automatically if any of the following conditions occurs: <ul style="list-style-type: none"> • A file with the same name already exists. • There is insufficient space at the file destination. • The number of characters in the full path name for the file exceeds 255 characters. 	Change the file name, remaining capacity of the disk, or file path so that the data is saved automatically.

azbil

Yamatake Corporation
Advanced Automation Company

1-12-2 Kawana, Fujisawa
Kanagawa 251-8522 Japan

URL: <http://www.azbil.com>

Specifications are subject to change without notice. (08)

1st Edition: Issued in Nov. 2008 (B)