

## Insertion Temperature/Humidity Sensor

### Models HTY78X3, TY78X3, HY78X3

#### General

Insertion temperature/humidity sensor Model HTY78X3 series uses a Pt100 resistant thermometer sensor (JIS\* C1604 Class A, equivalent to IEC60751: 95 Class A) for a temperature sensing element, and a polymer capacitive humidity sensor (FP3™ specially developed by Yamatake Corp.) for a humidity sensing element, enhancing accuracy and reliability of temperature/humidity sensing. With wide sensing range and great stability, Model HTY78X3 series is suitable for various applications including building air conditioning (ducts and chambers) and meteorological observation as well as industrial applications. Model TY78X3 series temperature sensor and Model HY78X3 series humidity sensor are also available.

\* JIS: Japanese Industrial Standards.

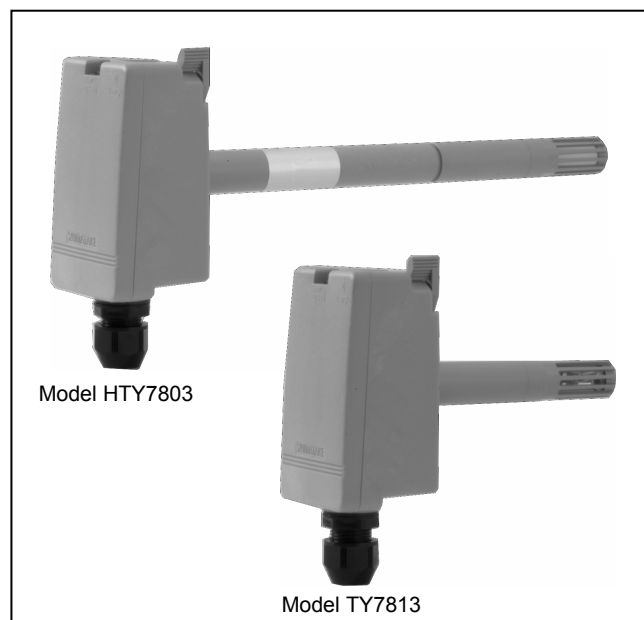

#### Features

- Wide temperature/humidity sensing range with high accuracy
- Highly environmental resistance
- Excellent long term stability
- Quick response and high repeatability
- Easy installation to a duct/chamber with quick-detachable bracket (dedicated)
- Dust-proof and splash-proof housing (IP54)
- Filterless probe of Model TY78X3 series (splash-proof enclosure)
- CE Marking certified product:  
Models HTY78X3T, HTY78X3Z, TY78X3T, TY78X3Z, HY78X3T, HY78X3Z conform to all the applicable standards of CE Marking.



















**Safety Instructions**

Please read instructions carefully and use the product as specified in this manual. Be sure to keep this manual near by for ready reference.

**Usage Restrictions**

This product is targeted for general air conditioning. Do not use this product in a situation where human life may be affected. If this product is used in a clean room or a place where reliability or control accuracy is particularly required, please contact Yamatake's sales representative. Yamatake Corporation will not bear any responsibility for the results produced by the operators.

 CAUTION

-  • Installation must be performed by qualified personnel in accordance with all applicable safety standards.
-  • This product must be operated within its operating ranges specified in this manual. Failure to comply will cause equipment damages.
-  • Installation must be carried out according to the operating conditions specified in this manual to prevent equipment damages.
-  • All wiring must comply with local codes of indoor wiring and electric installation rules.
-  • If more than the rated power supply voltage is applied, product replacement is required for safety.
-  • Lightning protection based on the regional characteristics and the building structure is necessary to minimize lightning damages to the product.
-  • Always disconnect power source before performing any wiring to prevent equipment damages.
-  • This product does not have a power switch. Be sure to install a power circuit breaker for the power source.
-  • Use crimp terminal lugs with insulation for electric wires.
-  • Do not disassemble the product. Equipment damages may result.
-  • When the product is faulty, reduced output may cause over-humidification. Provide safety measure on the controller side.
-  • Do not use two-way radio within 3 m radius of the product. The two-way radio may lower the product sensing accuracy.
-  • Product sensing accuracy is preset before shipment. Output of the product, used even in normal air, may be shifted depending on the operating conditions. Periodic inspection therefore may be required.
-  • Corrosive gas or organic solvent may damage the product or shift the product output. Before using the product in abnormal atmosphere, consult with Yamatake's sales personnel.
-  • Do not incinerate this product for waste disposal . Do not recycle all or part of this product, either.
-  • Dispose of this product as an industrial waste complying with the local regulations.

Trademark information:

FP3 is a trademark of Yamatake Corporation in Japan or in other countries.

### Model Numbers

Base model number	Shape	Type	Power supply	Humidity output	Temperature output	Fixed	Description
HTY78							Insertion temperature/humidity sensor
TY78							Insertion temperature sensor
HY78							Insertion humidity sensor
	0						Insertion length: Long
	1						Insertion length: Short
		3					—
			T				24 V DC / 24 V AC
			Z				No power supply required
			D				24 V DC
				0			Without humidity sensor
				1			Humidity output: 1-5 V
				4			Humidity output: 4-20 mA
				6			Humidity output: 0-10 V
					0		Without temperature sensor
					4		Temperature output: 4-20 mA
					P		Temperature: Pt100
						00	—

Select a model number from below.

Model number	Description	Insertion length
HTY7803T1P00	Humidity (1-5 V) + temperature (Pt100)	Long
HTY7803T4P00	Humidity (4-20 mA) + temperature (Pt100)	Long
HTY7803T6P00	Humidity (0-10 V) + temperature (Pt100)	Long
HTY7803D4400	2 wire: humidity (4-20 mA) + temperature (4-20 mA)	Long
HTY7813T1P00	Humidity (1-5 V) + temperature (Pt100)	Short
HTY7813T4P00	Humidity (4-20 mA) + temperature (Pt100)	Short
HTY7813T6P00	Humidity (0-10 V) + temperature (Pt100)	Short
HTY7813D4400	2 wire: humidity (4-20 mA) + temperature (4-20 mA)	Short
TY7803Z0P00	Temperature (Pt100)	Long
TY7803D0400	2 wire: temperature (4-20 mA)	Long
TY7813Z0P00	Temperature (Pt100)	Short
TY7813D0400	2 wire: temperature (4-20 mA)	Short
HY7803T1000	Humidity (1-5 V)	Long
HY7803T4000	Humidity (4-20 mA)	Long
HY7803T6000	Humidity (0-10 V)	Long
HY7803D4000	2 wire: humidity (4-20 mA)	Long
HY7813T1000	Humidity (1-5 V)	Short
HY7813T4000	Humidity (4-20 mA)	Short
HY7813T6000	Humidity (0-10 V)	Short
HY7813D4000	2 wire: humidity (4-20 mA)	Short

## Specifications

(1/2)

Item	Specification			
Measurement range	Temperature	-20 to 60 °C		
	Humidity	0 to 100 %RH (-5 to 55 °C)		
Output signal	Temperature	Models HTY78X3T, TY78X3Z series: 100 Ω / 0 °C Models HTY78X3D, TY78X3D series: 4 mA to 20 mA DC, 2 wire (linear to -20 °C to 60 °C) (Maximum allowable load: 500 Ω or lower)		
	Humidity	Models HTY78X3T1, HY78X3T1 series: 1 V DC to 5 V DC (linear to 0 to 100 %RH) (Input impedance of the controller connected: 10 kΩ or higher) Models HTY78X3T4, HY78X3T4 series: 4 mA DC to 20 mA DC (linear to 0 %RH to 100 %RH) (Maximum allowable load: 300 Ω or lower) Models HTY78X3T6, HY78X3T6 series: 0 V DC to 10 V DC (linear %RH to 0 to 100 %RH) (Input impedance of the controller connected: 10 kΩ or higher) Models HTY78X3D, HY78X3D series: 4 mA to 20 mA DC, 2-wire (linear to 0 %RH to 100 %RH) (Maximum allowable load: 500 Ω or lower)		
Sensing accuracy	Temperature	Models HTY78X3T, TY78X3Z series: ±0.3 °C (at -20 °C to 60 °C) (Pt100 element) Models HTY78X3D, TY78X3D series: ±0.3 °C (at 15 °C to 35 °C) / ±0.5 °C (at 0 °C to 50 °C)		
	Humidity	±3 %RH (at 30 %RH to 70 %RH, 25 °C) ±5 %RH (at 20 %RH to 80 %RH, 15 °C to 35 °C)		
Time constant (at 2 m/s air velocity)	Temperature	Model TY78X3Z series: 1 min. or less Model HTY78X3T series: 4 min. or less Models HTY78X3D, TY78X3D series: 4 min. or less		
	Humidity	1 min. or less		
Environmental conditions			Rated/extreme operating conditions	Transport/storage conditions
	Temperature measuring	Temperature range	-20 °C to 60 °C	-30 °C to 70 °C
		Humidity range	0 %RH to 100 %RH (non-condensing)	5 %RH to 95 %RH (non-condensing)
	Humidity measuring	Temperature range	Rated: -5 °C to 55 °C Extreme: -20 °C to 60 °C	-30 °C to 70 °C
		Humidity range	0 %RH to 100 %RH (non-condensing)	5 %RH to 95 %RH (non-condensing)
	Vibration		4.9 m/s <sup>2</sup> (10 Hz to 150 Hz)	9.8 m/s <sup>2</sup> (10 Hz to 150 Hz) (in packaged form)
Air velocity		Extreme: 0 m/s to 15 m/s	—	
Power supply voltage	Models HTY78X3T, HY78X3T series: 24 V AC +10/-15 % (50 Hz/60 Hz), 24 V DC ±10 % Models HTY78X3D, HY78X3D, TY78X3D series: 24 V DC ±10 %			
Power consumption	Models HTY78X3T1, HY78X3T1 series with 1-5 V output: 0.23 VA for 24 V AC / 170 mW for 24 V DC Models HTY78X3T4, HY78X3T4 series with 4-20 mA output: 1.0 VA for 24 V AC/ 800 mW for 24 V DC Models HTY78X3T6, HY78X3T6 series with 0-10 V output: 0.23 VA for 24 V AC / 170 mW for 24 V DC Models HTY78X3D, HY78X3D, TY78X3D series: 550 mW for 24 V DC (4-20 mA output per contact)			
Withstand voltage	1 mA or less leakage current at 500 V AC for 1 minute (between the housing and terminals)			
Insulation resistance	500 V DC, 20 MΩ or higher (between the housing and terminals)			
Enclosure rating	Housing: IP54 (dust-proof and splash-proof with specified water-proof gland and multi-core cables used or with specified conduit connected.) Probe of Model TY78X3Z series: IP24 (solid-proof (φ12 mm or greater) and splash-proof)			
Installation	Duct, chamber, thermometer shelter (with dedicated bracket)			
Connection	Terminal block connection			
Material, color	Housing: 20 % GF containing Polycarbonate resin, gray Filter cap: Modified PPE resin, gray			
Weight	Models HTY7803, TY7803, HY7803 series: Approx. 240 g Models HTY7813, TY7813, HY7813 series: Approx. 210 g			
Accessories	None			

Item	Specification
Parts (separate order required)	Part No. 83157235-001: Mounting bracket (packing, indicator label for installation holes, M4 screws) Part No. 83157240-004: Conduit mounting set (for Models HTY78X3D, HY78X3D, TY78X3D series, cable with $\phi$ 11 mm to $\phi$ 14 mm outer diameter is applicable.) Part No. 83157240-009: Conduit mounting set (for Model TY78X3Z series, cable with $\phi$ 9.4 mm to $\phi$ 11 mm outer diameter is applicable.) Part No. 83104098-004: Seal connector (for Models HTY78X3D, HY78X3D, TY78X3D series, cable with $\phi$ 10.5 mm to $\phi$ 14.5 mm outer diameter is applicable.) Part No. 83104098-003: Seal connector (for Model TY78X3Z series, cable with $\phi$ 8.5 mm to $\phi$ 12.5 mm outer diameter is applicable.) Part No. DY8000A1001: Sensor shield for outdoor Part No. DY3002A1005: Mounting bracket for thermometer shelter (L-type bracket)
Replacement part (separate order required)	Part No. 83162945-003: Filter set (filter, filter cap)

**Dimensions**

**Models HTY 7803, TY7803, HY7803 series**

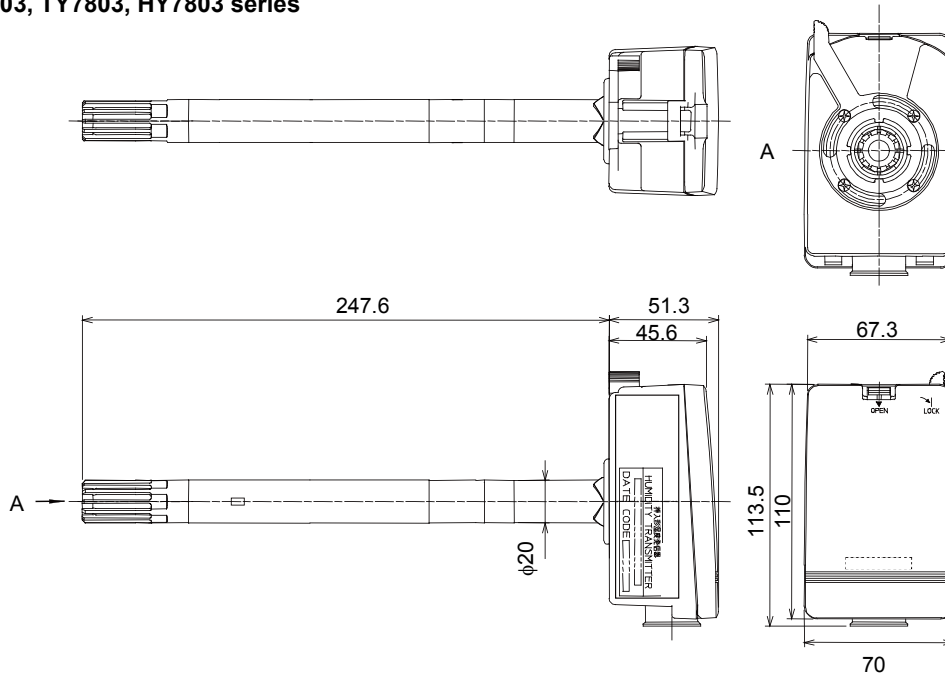

**Models HTY7813, TY7813, HY7813 series**

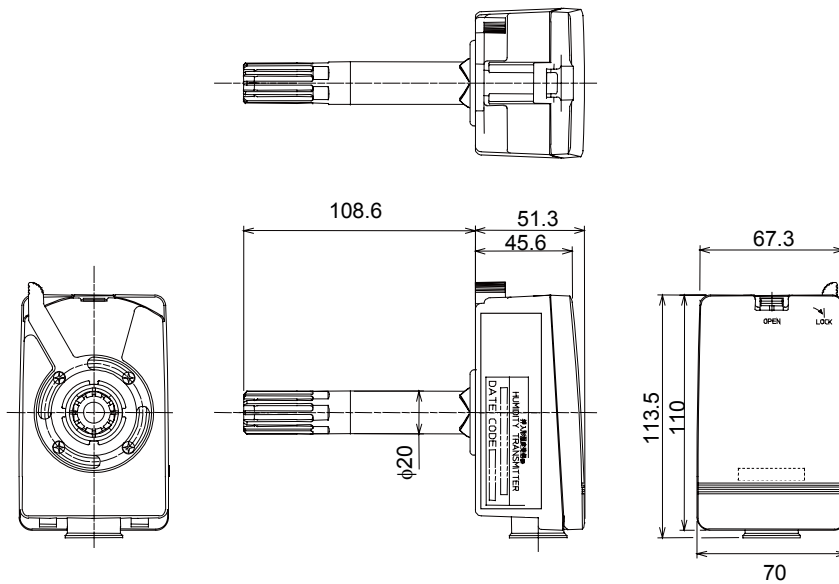

**Mounting bracket Part No. 83157235-001**

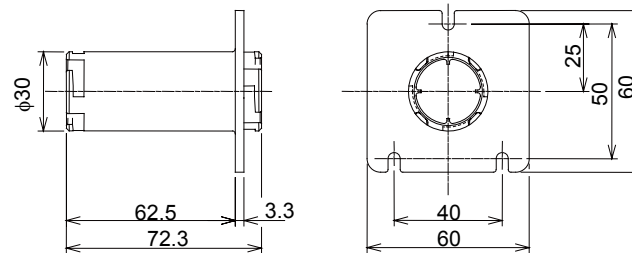
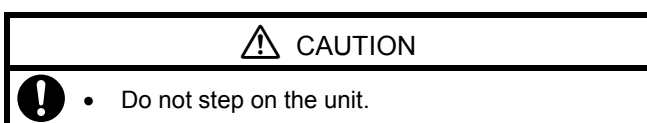

Figure 1. Dimensions (mm)

## Installation

### Installation requirements

- Select a location where the typical temperature and humidity of the measured gas can be sensed with the wind speed specified.
- Make sure that the entire probe is immersed in the measured gas. Also, make sure that airflow passes perpendicular to the side of the probe.
- Leave adequate maintenance clearance in front of the housing cover.
- When installing in steam-heating AHU, make sure the probe is not directly exposed to the high-temperature steam that exceeds the probe extreme operating condition.
- Do not install the sensor with the probe pointing upward.



### Installing Models HTY7803, TY7803, HY7803 series (for general AHU duct insertion)

- 1) Prepare the dedicated mounting bracket. Attach the indicator label for mounting hole at the probe mounting position, and make a mounting hole on the duct.

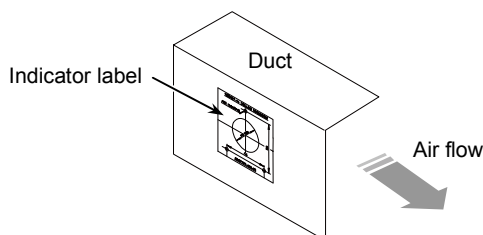

Figure 2. Indicator label on the duct

- 2) Fix the mounting bracket onto the duct with M4 screws (supplied with the bracket), inserting packing between the duct and the bracket. (The side with longer protruding part needs to face outward. See Fig. 3.)

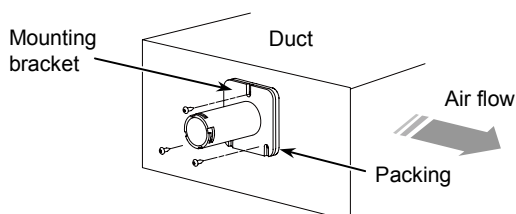

Figure 3. Mounting bracket on the duct

- 3) Cover the duct with an insulating material. (If the duct is already covered with it, partially remove the insulation material for the bracket. Then, fill the clearance between the bracket and the duct with the insulating material after fixing the bracket.)

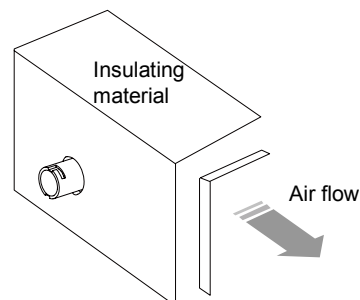

Figure 4. Duct and the mounting bracket covered with insulating material

- 4) Turn the main unit stopper (lock) 45 degree (from 'a' to 'b' shown in Fig. 5), and insert the probe of the main unit into the bracket as the main unit claws and the bracket slits match.

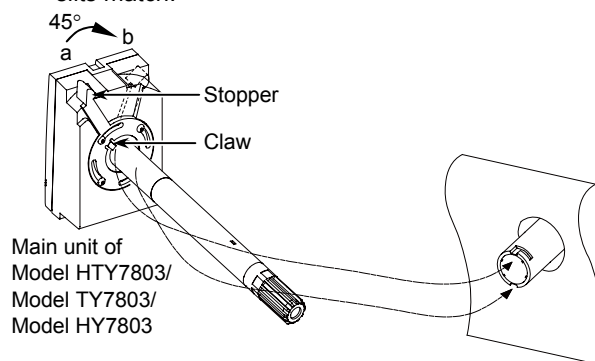

Figure 5. Mounting the main unit on the duct (with the mounting bracket)

- 5) Completely insert the probe into the duct. Then, fix the probe and the bracket by turning the stopper 45 degrees (from 'b' to 'a' (lock position) shown in Fig. 6).

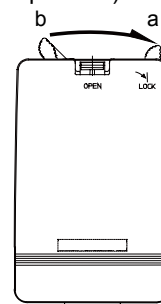

Figure 6. Fixing the main unit on the duct (with the mounting bracket)

**Installing Models HTY7813, TY7813, HY7813 series  
(for equipment, including chamber and thermometer  
shelter, insertion)**

- 1) Prepare the dedicated mounting bracket. Attach the indicator label for mounting hole at the probe mounting position, and make a mounting hole on the equipment panel.

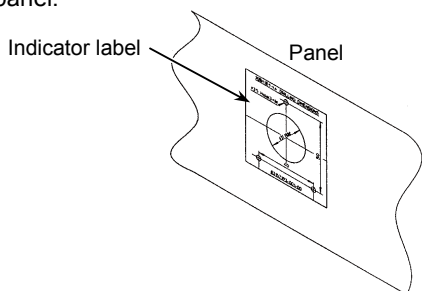

Figure 7. Indicator label on the panel

- 2) Fix the mounting bracket onto the equipment panel with M4 screws (supplied with the bracket). (The side with shorter protruding part needs to face outward. See Fig. 8.)

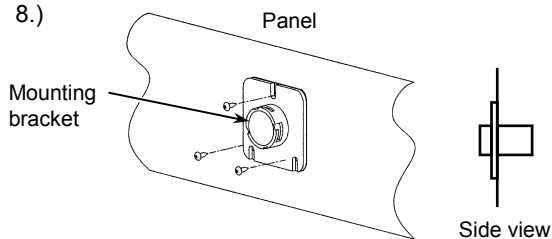

Figure 8. Mounting bracket on the panel

- 3) Turn the main unit stopper (lock) 45 degree (from 'a' to 'b' shown in Fig. 9), and insert the probe of the main unit into the bracket as the main unit claws and the bracket slits match.

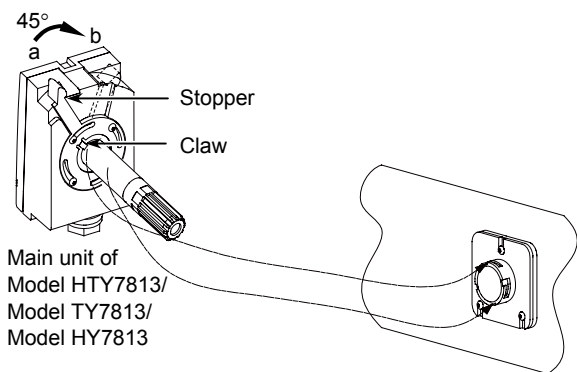

Figure 9. Mounting the main unit on the panel (with the mounting bracket)

- 4) Completely insert the probe into the panel. Then, fix the probe and the bracket by turning the stopper 45 degrees (from 'b' to 'a' (lock position) shown in Fig. 10).

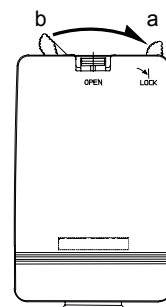

Figure 10. Fixing the main unit on the panel (with the mounting bracket)

**Wiring (common to Models HTY7803/TY7803/  
HY7803 and HTY7813/TY7813/HY7813 series)**

**Wiring procedure**

- 1) Detach the front cover.

Open the front cover by pressing the claw of the case. (See 'a' in Fig. 11.) At this time, open 30 degree wide or wider. (See 'b' in Fig. 11.) Then lift the front cover to detach. (See 'c' in Fig. 11.)

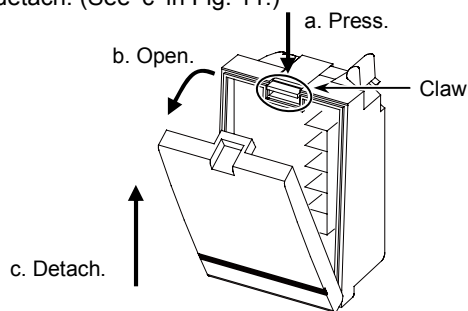

Figure 11. Detaching the front cover

- 2) Lead the cable through the wiring port.

Seal connector connection

Prepare the appropriate seal connector (with separate order required), depending on the quantity of core cables. Screw the threaded seal connector onto the wiring port and lead the cables through the port.

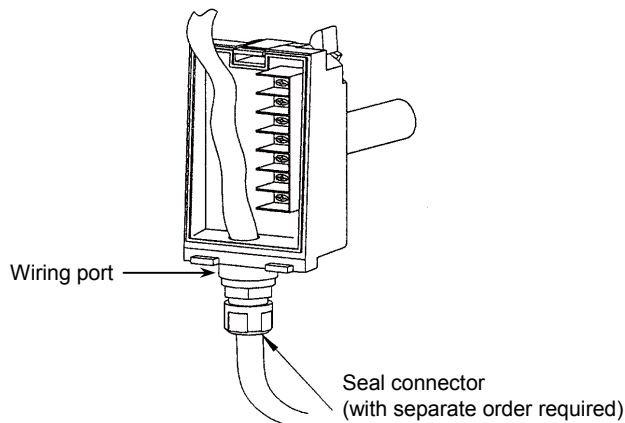

Figure 12. Seal connector connection

Conduit connection

Prepare the appropriate conduit set (with separate order required), depending on the quantity of core cables. Temporarily screw the conduit connector and the attachment, and select an O-ring appropriate for the cable.

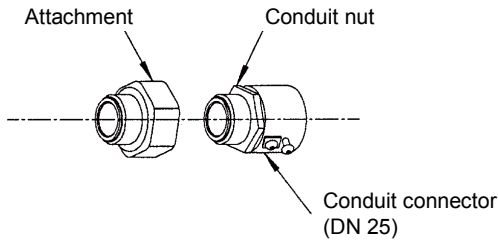

Figure 13. Conduit connection (1/2)

Lead the cable in, as shown in Fig. 14. Pull up the cable ('a' in Fig. 14) and screw the attachment onto the wiring port. Tighten the conduit nut on the conduit at a position where the conduit set screw can be tightened easily. Then, seal the wiring port ('b' in Fig. 14).

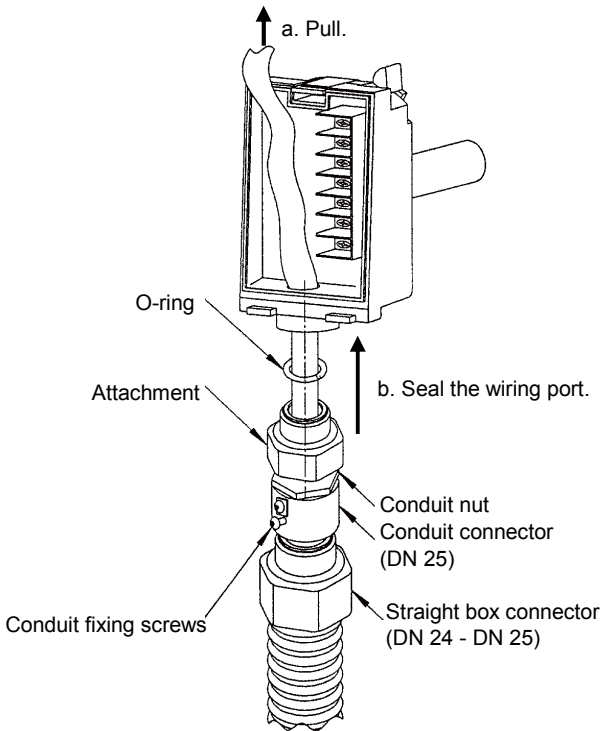

Figure 14. Conduit connection (2/2)

- 3) Connect the cables to the terminals. Connect the core cables to the terminals, and attach the front cover.

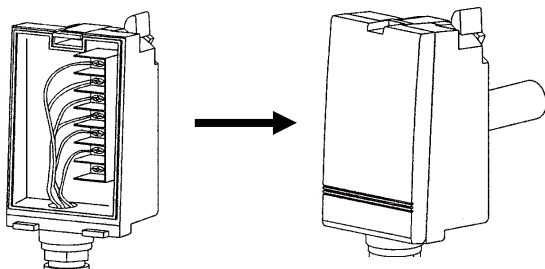

Figure 15. Attaching the front cover

Then, tighten the seal connector (for seal connector connection).

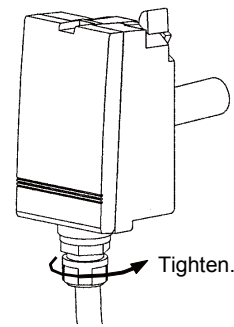

Figure 16. Tightening the seal connector

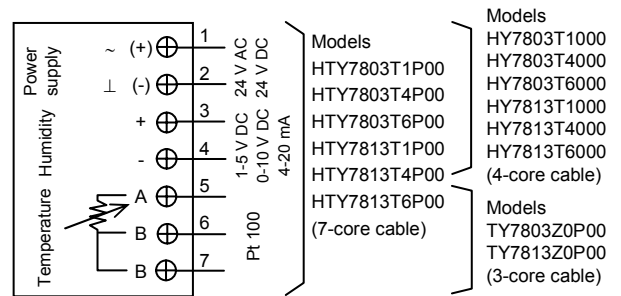

Figure 17. Connection of 7/4/3-core cables to terminals

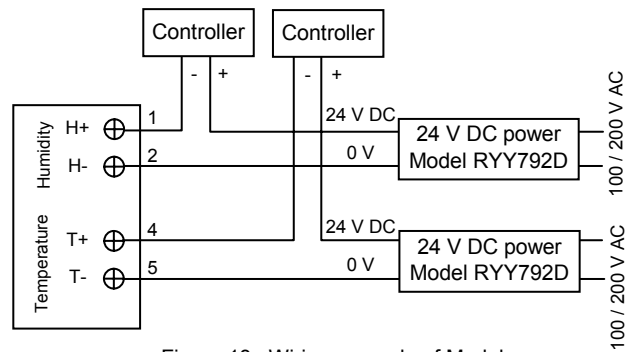

Figure 18. Wiring example of Model HTY78X3D/HY78X3D/TY78X3D

**⚠ CAUTION**

- Make sure all the wires are tightly connected. Heat generation or equipment malfunction may result. Insufficient tightening of the screw terminals may cause inaccurate measurement.
- Leave vacant terminals unconnected. Equipment damage may result.
- After completing wiring, be sure to attach the front cover.

**Wiring instructions**

- Shielded multi-core cables (JCS\* CVV-S cables) of 1.25 mm<sup>2</sup> or 2 mm<sup>2</sup> are recommended for power line and temperature/humidity output line. Be sure to ground the shielded cable on the controller side. For Model HTY78X3D/HY78X3D/TY78X3D series, ground the shielded cable on the sensor side as well.
- Without dust-proof or splash-proof enclosure, a 1.25 mm<sup>2</sup> or 2 mm<sup>2</sup> cable (JIS IV cable) can be used for power line and temperature output line, and a 1.25 mm<sup>2</sup> shielded cable for humidity output line. The maximum cable length is 100 m.
- Never connect power to temperature output terminal to the power supply to prevent smoking.
- Always check wiring before supplying power. Never share 24 V AC transformer with other products.

\* JCS: Japanese Electric Wire & Cable Makers' Association Standards

**Never share AC transformer for Model HY78/HTY78 with any other equipment.**

**⚠ CAUTION**

- Use insulated transformer to supply 24 V AC power. Never share 24 V AC power supply with other equipment. If a transformer is shared, loop will be formed at common and the sensor may be damaged.

24 V AC Transformer shared with two sensors

\* Fig. 19 shows wiring example of Model HY78X3T.

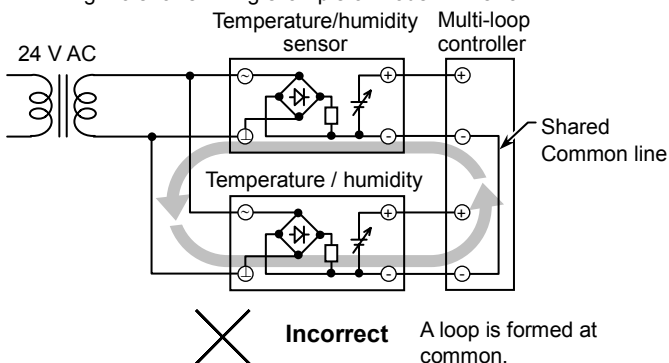

Figure 19. Incorrect wiring: shared 24 V AC transformer

Separate 24 V AC transformers for two sensors

\* Fig. 20 shows wiring example of Model HY78X3T.

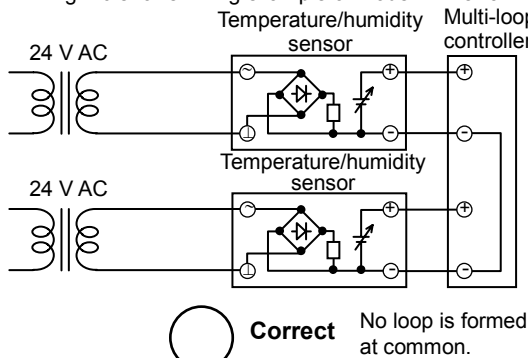

Figure 20. Correct wiring: separate 24 V AC transformers

24 V DC Transformer shared with two sensors (for Models HTY78X3T and HY78X3T)

- \* Fig. 21 shows wiring example of Model HY78X3T.
- \* For connecting terminals [-] and [E] (3 and 2), use power with 0.022 μF or lower capacitive coupling.

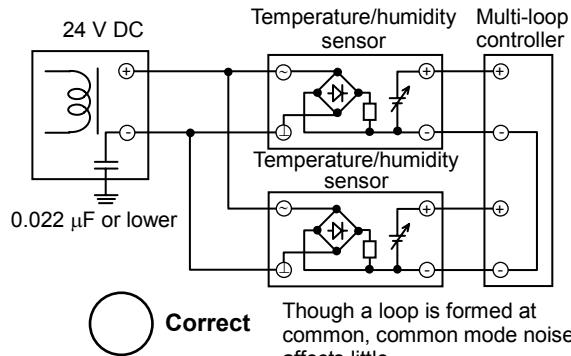

Figure 21. Correct wiring: shared 24 V DC transformer

Follow the below instructions to prevent an induction current flowing from the humidity sensor to the controller input circuit, or to prevent noise from generating due to inadequate time constant of the controller input.

- Use a controller with a low pass filter (40 dB or higher removal ratio in normal mode) for receiving signals.
- Connect an isolator to the controller input circuit if a removal ratio is not enough.
- No problem will occur for connecting with the controllers provided by Yamatake.

**⚠ CAUTION**

- Select sensor power supply based on the sensor allowable load including maximum current and power supply consumption.
- Do not use the transformer Model RYY792D (24 V DC power) for the sensor Model HY78X3T/HTY78X3T with 4-20 mA output. Insufficient capacity cause sensor malfunction.

### Maintenance

Since the temperature/humidity sensor is inspected and calibrated for high accuracy at the factory before shipment, no field calibration is necessary. Follow the maintenance instructions below:

### Periodic inspection

Periodically inspect the sensor for its sensing accuracy and clean the cover. Set the period between inspections based on atmospheric dust and other contaminants in the installation environment.

### Troubleshooting

If any problem occurs during operation, refer to the following table for appropriate solutions.

#### Troubleshooting and solution

Problems	Check items	Solutions
<ul style="list-style-type: none"> <li>No output generated</li> <li>Unstable output</li> </ul>	<ul style="list-style-type: none"> <li>Loose wiring</li> <li>Disconnected wiring</li> <li>Power supply voltage</li> <li>Sensor damages</li> </ul>	<ul style="list-style-type: none"> <li>Tighten the terminal block.</li> <li>Re-perform wiring.</li> <li>Replace the sensor.</li> </ul>
<ul style="list-style-type: none"> <li>Slow response to output</li> </ul>	<ul style="list-style-type: none"> <li>Moisture/condensation on the sensor</li> </ul>	<ul style="list-style-type: none"> <li>Detach the main unit from the bracket, and remove the filter cap and the filter. Dry power-off state sensor in clean air seasoning.</li> </ul>
<ul style="list-style-type: none"> <li>Error in output</li> </ul>	<ul style="list-style-type: none"> <li>Installed location</li> <li>Dust and contamination on the sensor</li> </ul>	<ul style="list-style-type: none"> <li>Refer to the 'Installation requirements'.</li> <li>Clean the filter.</li> <li>Replace the filter.</li> <li>Perform humidity single-point calibration.</li> <li>Replace the sensor.</li> </ul>

### Filter replacement:

**⚠ CAUTION**

- Installation must be performed by qualified personnel in accordance with all applicable safety standards.
- Be sure not to touch the print board and other parts when they are not covered by the filter cap or the filter.

1) Prepare the new filter set (with separate order required) to replace with. Remove the old filter cap and filter (to replace) by hand.

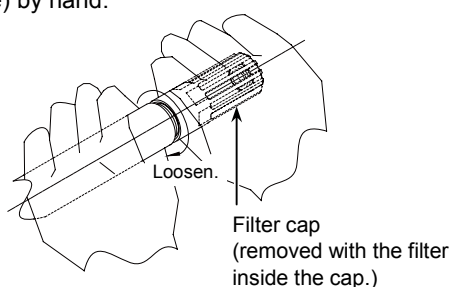

Figure 22. Filter cap removal

2) Before attaching the new filter, check that the rubber packing sealing the sensing element is not raised from the probe, as shown in Fig. 23.

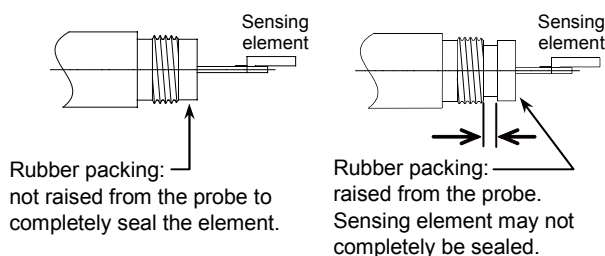

Figure 23. Rubber packing position

For rubber packing raised, press it using a slotted screwdriver as shown in Fig. 24.

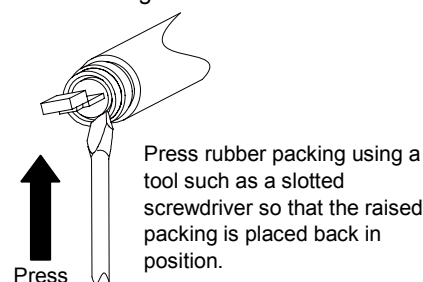

Figure 24. Pressing rubber packing

**⚠ CAUTION**

- Carefully press the rubber packing. Personal injury may result when your fingers holding the tool slip.
- Carefully handle the tool so as not to damage the packing or other part of the product.

3) Cover the sensing element with the new filter and then with the new filter cap.

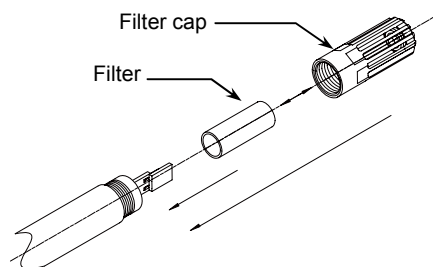

Figure 25. Attaching new filter and filter cap

4) Hand-tighten the filter cap.

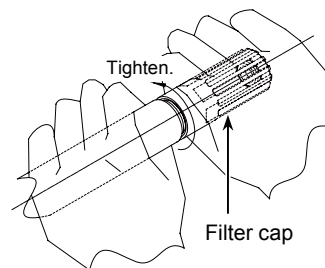

Figure 26. Tightening new filter cap

**Humidity single-point calibration  
for Model HY78X3T/HTY78X3T**

When you find an output error of the humidity sensor, the sensor can be calibrated with the adjustment knob RH1 located inside the humidity sensor.

Output value is increased by turning RH1 clockwise, and decreased by turning counterclockwise.

Use a reliable measuring instrument for single-point calibration with correct procedure in appropriate environment. Calibrated digital multimeter is recommended to check output.

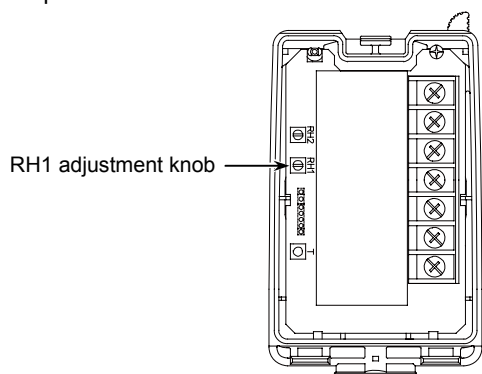

Figure 27. Single-point calibration: Model HY78X3T/HTY78X3T

**Handling Precautions**

- After installation, leave the sensor for approx. 24 hours to adapt to ambient conditions (atmospheric environment).
- Be sure not to affect the sensor with heat generated from human body and/or appliances while calibrating the sensor.

**azbil**

*Specifications are subject to change without notice.*

**Yamatake Corporation**  
**Building Systems Company**

<http://www.yamatake.com>